



# Executive Committee Agenda

Click link to access the meeting:

<https://us02web.zoom.us/j/94562188418>





Zoom Meeting ID

## Ways to Join



**Computer:** Click the link above. You will be prompted to run the Zoom browser or Zoom application. Once signed on to the meeting, you will have the option to join using your computer audio system or phone.

### Webinar Features:

	▶	Use the <b>raise hand</b> feature every time you wish to make a public comment.
	▶	Participants can enable <b>closed captioning</b> by clicking the CC icon. You may also view the full transcript and change the font size by clicking 'subtitle settings'. These features are not available via phone.
	▶	This symbol shows you are <b>muted</b> , click this icon to unmute your microphone.
	▶	This symbol shows you are currently <b>unmuted</b> , click this button to mute your microphone.
	▶	The chat feature should be used by panelists and attendees solely for "housekeeping" matters as comments made through this feature will not be retained as part of the meeting record. See the <b>Live Verbal Public Comment</b> for instructions on how to make a public comment.



**Smartphone or Tablet:** Download the Zoom app and join the meeting by clicking the link or using the webinar ID (found in the link).



### Phone:

1. If you are joining the meeting audio by phone and viewing the meeting on a device, dial the number provided in the 'join audio' phone call tab of the initial pop-up, and enter the Meeting ID (found in the link).
2. If you are joining by phone only, dial: **+1-669-900-9128** or **+1-253-215-8782** and type the meeting ID found in the link, press #. You will have access to the meeting audio, **but will NOT be able to view the PowerPoint presentations.**



### Live Verbal Public Comments:

Use the 'Raise Hand' icon every time you wish to make a public comment on an item. Raise your hand once the agenda item you wish to comment on has been called. In person public comments will be taken first, virtual attendees will be taken in the order in which they raise their hand. Requests to speak will not be taken after the public comment period ends, unless under the Chair's discretion. General Public Comment, at the beginning of the Board of Directors meeting only, will be limited to five speakers. Additional speakers with general public comments will be heard at the end of the meeting. Two-minutes of time is allotted per speaker, unless otherwise directed by the Chair.

### Public Comments Made Via Zoom

1. Click the link found at the top of this instruction page
2. Click the raise hand icon located in the bottom center of the platform
3. The Clerk will announce your name when it is your turn to speak
4. Unmute yourself to speak

### Public Comments Made by Phone Only

1. Dial **+1-669-900-9128**
2. Type in the zoom meeting ID found in the link and press #
3. Dial \*9 to raise your hand via phone
4. The Clerk will call out the last 4 digits of your phone number to announce you are next to speak
5. Dial \*6 to unmute yourself



**Written Public Comments (before the meeting):** Written public comments will be recorded in the public record and will be provided to MTS Board Members in advance of the meeting. Comments must be emailed or mailed to the Clerk of the Board\* by 4:00pm the day prior to the meeting.

---



**Translation Services:** Requests for translation services can be made by contacting the Clerk of the Board\* at least four working days in advance of the meeting.

---



**In-Person Participation:** In-person public comments will be heard first. Following in-person public comments, virtual attendees will be heard in the order in which they raise their hand via the Zoom platform. Speaking time will be limited to two minutes per person, unless specified by the Chairperson. Requests to speak will not be taken after the public comment period ends, unless under the Chair's discretion.

**Instructions for providing in-person public comments:**

1. Fill out a speaker slip located at the entrance of the Board Room;
2. Submit speaker slip to MTS staff seated at the entrance of the Board Room;
3. When your name is announced, please approach the podium located on the right side of the dais to make your public comments.

Members of the public are permitted to make general public comment at the beginning of the agenda or specific comments referencing items on the agenda during the public comment period. General Public Comment, at the beginning of the Board of Directors meeting only, will be limited to five speakers. Additional speakers with general public comments will be heard at the end of the meeting.

---



**Assistive Listening Devices (ALDs):** ALDs are available from the Clerk of the Board\* prior to the meeting and are to be returned at the end of the meeting.

---



**Reasonable Accommodations:** As required by the Americans with Disabilities Act (ADA), requests for agenda information in an alternative format or to request reasonable accommodations to facilitate meeting participation, please contact the Clerk of the Board\* at least two working days prior to the meeting.

---



**\*Contact Information:** Contact the Clerk of the Board via email at [ClerkoftheBoard@sdmts.com](mailto:ClerkoftheBoard@sdmts.com), phone at (619) 398-9681 or by mail at 1255 Imperial Ave. Suite 1000, San Diego CA 92101.



# Agenda del Comité Ejecutivo

Haga clic en el enlace para acceder a la reunión:

<https://us02web.zoom.us/j/94562188418>





ID de la reunión  
en Zoom

## Formas de Participar



**Computadora:** Haga clic en el enlace más arriba. Recibirá instrucciones para operar el navegador de Zoom o la aplicación de Zoom. Una vez que haya iniciado sesión en la reunión, tendrá la opción de participar usando el sistema de audio de su computadora o teléfono.

## Funciones del Seminario En Línea:

 Levantar la mano	▶	Use la herramienta de <b>levantar la mano</b> cada vez que desee hacer un comentario público.
	▶	Los participantes pueden habilitar el <b>subtitulado</b> haciendo clic en el ícono CC. También puede ver la transcripción completa y cambiar el tamaño de letra haciendo clic en “configuración de subtítulos”. Estas herramientas no están disponibles por teléfono.
	▶	Este símbolo indica que usted se encuentra en <b>silencio</b> , haga clic en este ícono para quitar el silenciador de su micrófono.
	▶	Este símbolo indica que su micrófono se encuentra <b>encendido</b> . Haga clic en este símbolo para silenciar su micrófono.
	▶	La herramienta de chat deben usarla los panelistas y asistentes únicamente para asuntos “pertinentes a la reunión”, ya que comentarios realizados a través de esta herramienta no se conservarán como parte del registro de la reunión. Consulte el <b>Comentario público verbal</b> en vivo para obtener instrucciones sobre cómo hacer un comentario público.



**Teléfono Inteligente o Tableta:** Descargue la aplicación de Zoom y participe en la reunión haciendo clic en el enlace o usando el ID del seminario web (que se encuentra en el enlace).



## Teléfono:

1. Si está participando en la reunión mediante audio de su teléfono y viendo la reunión en un dispositivo, marque el número indicado en la pestaña de llamada telefónica “unirse por audio” en la ventana emergente inicial e ingrese el ID de la reunión (que se encuentra en el enlace).
2. Si está participando solo por teléfono, marque: **+1-669-900-9128** o **+1-253-215-8782** e ingrese el ID de la reunión que se encuentra en el enlace, pulse #. Tendrá acceso al audio de la reunión, **pero NO podrá ver las presentaciones en PowerPoint.**



**Comentarios Públicos Verbales en Vivo:** Use la herramienta “levantar la mano” cada vez que desee hacer un comentario público sobre alguno de los artículos. Levante la mano una vez que el artículo de la agenda sobre el que desea comentar haya sido convocado. Los comentarios públicos en persona se escucharán primero, se escuchará a los asistentes virtuales en el orden en el que levanten la mano. No se aceptarán solicitudes para hablar después de que termine el periodo para hacer comentarios públicos, a menos de que el presidente determine de otra forma a su discreción. Comentarios públicos generales, únicamente al inicio de la reunión de la Junta de Directores, se limitarán a cinco personas que deseen hablar. Las personas adicionales que deseen aportar comentarios públicos generales podrán hacerlo al final de la reunión. Se otorga dos minutos de tiempo por persona que desee hablar, a menos de que el presidente instruya de otra forma. *(Consulte la página 2 para obtener instrucciones sobre cómo hacer un comentario público.)*

## Comentarios Públicos a Través de Zoom

1. Haga clic en el enlace que se encuentra en la parte superior de esta página de instrucciones
2. Haga clic en el ícono de levantar la mano en el centro inferior de la plataforma
3. El secretario anunciará su nombre cuando sea su turno de hablar
4. Desactive el silenciador para que pueda hablar

## Comentarios Públicos Realizados Únicamente por Teléfono

1. Marque el **+1-669-900-9128**
2. Ingrese el ID de la reunión en Zoom que se encuentra en el enlace y pulse #
3. Marque \*9 para levantar la mano por teléfono
4. El secretario indicará los últimos 4 dígitos de su número de teléfono para anunciar que usted será el siguiente en hablar
5. Marque \*6 para desactivar el silenciador



**Comentarios Públicos por Escrito (Antes de la Reunión):** Los comentarios públicos por escrito se registrarán en el registro público y se entregarán a los miembros de la Junta de MTS antes de la reunión. Los comentarios deben enviarse por correo electrónico o postal al secretario de la Junta\* antes de las 4:00 p.m. el día anterior a la reunión.



**Servicios de Traducción:** Pueden solicitarse servicios de traducción comunicándose con el secretario de la Junta\* por lo menos cuatro días hábiles antes de la reunión.



**Participación en Persona:** Los comentarios públicos en persona se escucharán primero. Después de los comentarios públicos en persona, se escuchará a los asistentes virtuales en el orden en el que levanten la mano a través de la plataforma de Zoom. El tiempo para hablar se limitará a dos minutos por persona, a menos de que el presidente especifique de otra forma. No se recibirán solicitudes para hablar después de que termine el periodo para hacer comentarios públicos, a menos de que el presidente determine de otra forma a su discreción.

### Instrucciones para brindar comentarios públicos en persona:

1. Llene la boleta para personas que desean hablar que se encuentran en la entrada de la Sala de la Junta.
2. Entregue la boleta para personas que desean hablar al personal de MTS que se encuentra sentado en la entrada de la Sala de la Junta.
3. Cuando anuncien su nombre, por favor, acérquese al podio ubicado en el lado derecho de la tarima para hacer sus comentarios públicos.

Los miembros del público pueden hacer comentarios públicos generales al inicio de la agenda o comentarios específicos que hagan referencia a los puntos de la agenda durante el periodo de comentarios públicos. Los comentarios públicos generales únicamente al inicio de la reunión de la Junta de Directores, se limitarán a cinco personas que deseen hablar. Las personas adicionales que deseen aportar comentarios públicos generales podrán hacerlo al final de la reunión.



**Dispositivos de Asistencia Auditiva (ALD, por sus siglas en inglés):** Los ALD están disponibles con el secretario de la Junta\* antes de la reunión y estos deberán ser devueltos al final de la reunión.



**Facilidades Razonables:** Según lo requerido por la Ley de Estadounidenses con Discapacidades (ADA, por sus siglas en inglés), para presentar solicitudes de información de la agenda en un formato alternativo o solicitar facilidades razonables para facilitar su participación en la reunión, por favor, comuníquese con el secretario de la Junta\* por lo menos dos días hábiles antes de la reunión.



**\*Información de Contacto:** Comuníquese con el secretario de la Junta por correo electrónico en [ClerkoftheBoard@sdmts.com](mailto:ClerkoftheBoard@sdmts.com), por teléfono al **(619) 398-9681** o por correo postal en **1255 Imperial Ave. Suite 1000, San Diego CA 92101.**



**Metropolitan  
Transit  
System**

## **Executive Committee Agenda**

April 11, 2024 at 9:00 a.m.

**In-Person Participation:** James R. Mills Building, 1255 Imperial Avenue, 10th Floor Board Room, San Diego CA 92101

**Teleconference Participation:** (669) 444-9171; Webinar ID: 945 6218 8418, <https://us02web.zoom.us/j/94562188418>

NO.	ITEM SUBJECT AND DESCRIPTION	ACTION
1.	<b>Roll Call</b>	
2.	<b>Public Comments</b> This item has a two minute per speaker time limit. If you have a report to present, please give your copies to the Clerk of the Board.	
3.	<b>Approval of Minutes</b> Action would approve the March 7, 2024 Executive Committee meeting Minutes.	Approve
DISCUSSION AND REPORT ITEMS		
4.	<b>Independent Salary Study Results – Implementation of Recommended Pay Grades and Ranges</b> Action would forward a recommendation to the Board of Directors to: (1) adopt the pay ranges recommended by independent compensation consultant The Segal Company effective May 1, 2024, and (2) authorize the Chief Executive Officer (CEO) to implement the results of the independent compensation study.	Adopt/Approve
OTHER ITEMS		
5.	<b>Review of Draft April 25, 2024 MTS Board Agenda</b>	
6.	<b>Staff Communications and Committee Member Communications</b>	
7.	<b>Next Meeting Date: May 9, 2024</b>	
8.	<b>Adjournment</b>	



MINUTES  
MEETING OF THE SAN DIEGO METROPOLITAN TRANSIT SYSTEM  
EXECUTIVE COMMITTEE

March 7, 2024

[Clerk's note: Except where noted, public, staff and board member comments are paraphrased. The full comment can be heard by reviewing the recording at the [MTS website](#).]

**1. Roll Call**

Chair Whitburn called the Executive Committee meeting to order at 9:02 a.m. A roll call sheet listing Executive Committee member attendance is attached.

**2. Public Comment**

Ozzy Meneses – Provided a verbal statement to the Board during the meeting. Ozzy outlined his work history and advertised his consulting business on public affairs and relations.

The Original DRA – Provided a verbal statement to the Board during the meeting. The Original DRA expressed dissatisfaction with alleged asylum seekers that were utilizing free public transportation and believed that the youth opportunity pass (YOP) is dangerous for youth without additional security measures.

**3. Approval of Minutes**

Board Member Moreno moved to approve the minutes of the February 1, 2024, MTS Executive Committee meeting. Vice Chair Goble seconded the motion, and the vote was 5 to 0 in favor with Board Member Montgomery Steppe and Board Member Bush absent.

**DISCUSSION ITEMS**

**4. Rapid 227 Service in Imperial Beach (Denis Desmond)**

Denis Desmond, MTS Director of Planning and Scheduling, along with Beverly Neff, Senior Transportation Planner, presented on Rapid 227 Service in Imperial Beach. Mr. Desmond outlined: the route timeline, grant funding, ridership, and current and future service in Imperial Beach.

**Committee Comment**

Board Member Moreno did not support changes to the route that would reduce her community's access to the beach. She deferred to MTS staff as the expert matter for such recommendations for route adjustments.

Board Member Elo-Rivera encouraged additional public education outreach. Sharon Cooney, MTS Chief Executive Officer, acknowledged that historically, various communities throughout the region have expressed route push back on new routes, and now, those same communities advocate for additional transit options.

**Action Taken**

No action taken. Informational item only.

**5. Vehicle Assignment and Transit Amenities Policies (Samantha Leslie & Denis Desmond)**

Mr. Desmond and Samantha Leslie MTS Deputy General Counsel, presented on Vehicle Assignment and Transit Amenities Policies. They outlined: Title VI policy background, vehicle assignment policy, transit amenities policy, monitoring policies, and next steps.

**Committee Comment**

Board Member Moreno believed that MTS amenities are critical to attracting and retaining ridership. She asked staff to show which stops would have enhanced amenities if funding was available. She added that the agency's goal should be to develop a plan to identify bus stops in the service area that should receive enhanced amenities, asked for a cost estimate of such analysis, and encouraged staff to seek funding. Board Member Moreno advocated for a transit amenities plan, coupled with the policy. She also suggested revising the proposed policy to include the operation and maintenance of restrooms, along with identifying gaps in restroom access across the system. Board Member Moreno also advocated for a minimum number of validators at each platform.

Vice Chair Goble asked staff to explain the distinction between active memorandum of understanding agreements (MOU) and no MOU referenced in the key to slide 7. Mr. Desmond replied that some cities have agreements for MTS to provide amenities, while others do not. He asked who would fund the addition or enhancement of amenities. Mr. Desmond replied that unless there is an MOU in place, each city is responsible for enhancements and additions of bus stop amenities. Vice Chair Goble asked if MTS would be open to establishing additional agreements. Ms. Cooney confirmed that MTS is open to growing those agreements. She noted that while this would reduce Transportation Development Act (TDA) funding to the applicable city, it would allow MTS to upgrade the station and generate advertisement revenue. Vice Chair Goble asked if all shelters would have advertisement displays. Mr. Desmond noted that advertisements are based on the infrastructure and location of shelters.

Board Member Elo-Rivera asked if all of MTS's amenities are supported by contractors. Mr. Desmond responded that depending on the amenity and location, bus shelters, bus benches, elevators and escalators are serviced by MTS contractors; and transit centers, trolley stations, ticket vending machines and validators are serviced by MTS staff. Board Member Elo-Rivera asked how the agency determines when MTS staff versus a contractor should perform the work. Mr. Desmond replied that due to the volume of bus amenities, these services are more often contracted out. Karen Landers, MTS General Counsel, added that advertisement obligations have been bundled with the maintenance of the bus stop amenities. Board Member Elo-Rivera was curious if amenities attracted ridership, and encouraged CalEnviroScreen as a useful tool to assure equity in amenities across the system. Board Member Elo-Rivera asked staff if it would be helpful to articulate the Board's directive for restrooms through a formal policy. Ms. Cooney assured the Board that staff understands the Board's directive and noted the transit-oriented development restrooms being built. She stated that staff is actively working with the jurisdictions of adjacent restroom owners to MTS stops. She listed an MOU agreement slated for the Board's approval at the upcoming May meeting for SDSU station restroom re-opening. Board Member Elo-Rivera advocated for the access of restrooms in heavily transited bus and trolley stops, and he was concerned about how MTS was prioritizing restroom access. He also asked about the re-implementation timeline of a bus bench in his jurisdiction. Mr. Desmond assured Board Member Elo-Rivera that they would check on the status of the bus bench.

Vice Chair Goble asked about advertisement at bus shelters. He expressed concern over alcohol advertisements that would be advertised in low-income communities. He asked if it would be possible to exclude such advertisements in his region.

**Action Taken**

No action taken. Informational item only.

OTHER ITEMS

**6. Review of Draft March 14, 2024 Board Agenda**

Recommended Consent Items

**3. Approval of Minutes**

Action would approve the February 8, 2024 Board of Director meeting minutes.

**4. Public Hearing: Proposed Amendments to For-Hire Vehicle Services Regulations**

Action would 1) Adopt the proposed amendments to MTS Ordinance No. 11 “An Ordinance Providing for the Licensing and the Regulating of Transportation Services within the City and the County by the Adoption of a Uniform Paratransit Ordinance”; 2) Waive the requirements of MTS Board Policy No. 22 “Rules of Procedure for MTS Board of Directors,” Sections 22.4.3, stating all ordinances shall be read in full either at the time of introduction or passage (per MTS Board Policy No. 22, unanimous vote of the Board members present is required in order to waive further reading); and 3) Approve the proposed revisions to MTS Board Policy No. 34 “For-Hire Vehicle Services.”

**5. Adoption of 2024 Conflict of Interest Code – Amendment**

Action would 1) Adopt Resolution No. 24-02 amending the MTS Conflict of Interest Code pursuant to the Political Reform Act of 1974; 2) Adopt the amended 2024 MTS Conflict of Interest Code; and 3) Forward the amended 2024 MTS Conflict of Interest Code to the County of San Diego (the designated code-reviewing body) (Gov. Code § 82011) requesting approval of the amendment as required under Government Code section 87303.

**6. Addition of Full-Time Equivalent (FTE) Position: Staff Attorney**

Action would authorize the Chief Executive Officer (CEO) to add one (1) Staff Attorney to the position tables previously approved in the Fiscal Year 2024 budget.

**7. Investment Report – Quarter Ending December 31, 2023**

**8. Bayside Double Track Imperial Avenue Transit Center (IMT) Construction Management (CM) Services – Work Order Amendment**

Action would authorize the Chief Executive Officer (CEO) to execute Work Order No. WOA2498-CM05.01 under MTS Doc. No. G2498.0-21, with Kleinfelder Construction Services, Inc. (KCS), to CM Services for the Bayside Double Track IMT project in the amount of \$318,443.22.



- 9. Trolley On-Board Video Surveillance System (OBVSS) Preventative Maintenance, Repairs and All Related Support Services – Contract Amendment**  
Action would authorize the Chief Executive Officer (CEO) to execute MTS Doc. No. L1603.2-22 with Seon Design USA Corp (“Seon”) for twenty (20) NH16 systems and cameras with installation in the amount of \$238,545.00.
- 10. On-Call Job Order Contracting (JOC) Building and Facilities Construction Services – Contract Amendment**
- 11. On-Call Job Order Contracting (JOC) General Civil Construction Services – Contract Amendment**
- 12. On-Call Job Order Contracting (JOC) Railroad Construction Services – Contract Amendment**
- 13. Job Order Contracting (JOC) Consulting Programming Software Services – Contract Amendment**
- 14. Propane Fueling Services at Copley Park Division (CPD) – Contract Award**  
Action would 1) authorize the Chief Executive Officer (CEO) to execute MTS Doc. No. B0760.0-24 with Suburban Propane for Propane Fueling Services, in the amount of \$14,409,695.44, for a five (5) base year period with two (2) 1-year options, for a total of seven (7) years; and 2) 1) Exercise option years at CEO’s discretion.
- 15. SAP Support Services – Contract Award**  
Action would 1) Authorize the Chief Executive Officer (CEO) to execute MTS Doc. No. G2782.0-24 with Sage Group Technologies, Inc. (Sage) to provide SAP support services in the amount of \$600,000.00 for a contract period of thirty-two (32) months with one (1) option year. 2) Authorize the CEO to execute MTS Doc. No. G2783.0-24 with Sierra Digital, Inc. (Sierra), a Disadvantaged Business Enterprise (DBE), to provide SAP support services in the amount of \$600,000.00 for a contract period of thirty-two (32) months with one (1) option year. 3) Exercise the option year of each agreement at the CEO’s discretion.
- 16. Light Rail Vehicle (LRV) Pantograph Carbon Strips - Contract Award**  
Action would authorize the Chief Executive Officer (CEO) to execute MTS Doc. No. L1660.0-24 with Schunk Carbon Technology (Schunk) for the purchase of LRV Pantograph Carbon Strips for a five (5) year base period in the amount of \$687,536.59.
- 17. Property Insurance Renewal**
- 18. Excess General Liability (Liability) And Excess Workers’ Compensation (Workers’ Compensation) Insurance Renewals**

**7. Other Staff Communications and Business**

There was no Other Staff Communications and Business discussion.

**8. Committee Member Communications and Other Business**

There was no Committee Member Communications and Other Business discussion.

**9. Next Meeting Date**

The next Executive Committee meeting is scheduled for April 11, 2024, at 9:00 a.m.

**10. Adjournment**

The meeting was adjourned at 9:50 a.m.

---

Chairperson  
San Diego Metropolitan Transit System

---

Clerk of the Board  
San Diego Metropolitan Transit System

Attachment: Roll Call Sheet

SAN DIEGO METROPOLITAN TRANSIT SYSTEM  
EXECUTIVE COMMITTEE

ROLL CALL

MEETING OF (DATE): March 7, 2024 CALL TO ORDER (TIME): 9:02 a.m.  
 RECESS: \_\_\_\_\_ RECONVENE: \_\_\_\_\_  
 CLOSED SESSION: \_\_\_\_\_ RECONVENE: \_\_\_\_\_  
 PUBLIC HEARING: \_\_\_\_\_ RECONVENE: \_\_\_\_\_  
 ORDINANCES ADOPTED: \_\_\_\_\_ ADJOURN: 9:50 a.m.

REPRESENTING	BOARD MEMBER	ALTERNATE	PRESENT (TIME ARRIVED)	ABSENT (TIME LEFT)
Chair	Whitburn <input checked="" type="checkbox"/>	No Alternate <input type="checkbox"/>	9:02 a.m.	9:50 a.m.
City of San Diego	Elo-Rivera <input checked="" type="checkbox"/>	Joe LaCava <input type="checkbox"/>	9:05 a.m.	9:50 a.m.
County of San Diego	Montgomery Steppe <input type="checkbox"/>	Vargas <input type="checkbox"/>	ABSENT	ABSENT
East County	Frank <input checked="" type="checkbox"/>	Hall <input type="checkbox"/>	9:02 a.m.	9:50 a.m.
SANDAG Transportation Committee	Moreno <input checked="" type="checkbox"/>	Bush <input type="checkbox"/>	9:02 a.m.	9:50 a.m.
South Bay	Bush <input type="checkbox"/>	Leyba- Gonzalez <input type="checkbox"/>	ABSENT	ABSENT
Vice Chair	Goble <input checked="" type="checkbox"/>	No Alternate <input type="checkbox"/>	9:02 a.m.	9:50 a.m.

SIGNED BY THE CLERK OF THE BOARD: /S/ Dalia Gonzalez



**Metropolitan  
Transit  
System**

## **Agenda Item No. 4**

**MEETING OF THE SAN DIEGO METROPOLITAN TRANSIT SYSTEM  
EXECUTIVE COMMITTEE**

April 11, 2024

**SUBJECT:**

Independent Salary Study Results – Implementation of Recommended Pay Grades and Ranges

**RECOMMENDATION:**

That the San Diego Metropolitan Transit System (MTS) Executive Committee forward a recommendation to the Board of Directors to: (1) adopt the pay ranges recommended by independent compensation consultant The Segal Company effective May 1, 2024, and (2) authorize the Chief Executive Officer (CEO) to implement the results of the independent compensation study.

Budget Impact

A \$2,201,242 (6.25%) increase in unrepresented employee base salary cost is anticipated, based on the assumptions and constraints outlined below.

**DISCUSSION:**

Beginning in late 2021, many San Diego employers faced escalating challenges attracting and retaining qualified talent amid rising inflation, the region's high cost of living, and employment trends such as increased work from home opportunities and "The Great Resignation." MTS faced high frontline employee turnover and was having difficulty attracting applicants for frontline operations positions. In response, MTS adopted a multifaceted approach including improving schedules and other working conditions, as well as offering un negotiated pay increases to many of its represented employee groups. MTS's efforts to increase frontline employee pay led to pay compression within MTS's front-line supervisory positions.

MTS faces similar challenges attracting and retaining talent in its unrepresented workforce, which is comprised of individual contributors in a variety of roles (e.g., Information Technology, Procurement, and Human Resources), frontline bus and rail supervisors, and managerial positions. Exit interviews of departing employees in 2022 and 2023 show that the leading cause of unproductive/preventable turnover was employees leaving for higher compensation. Some departments experienced a 25% turnover rate in both years, indicating that approximately half of the current staff in those teams have less than two years of tenure with MTS. This level of



turnover leads to significant loss of organizational knowledge, reduced productivity during vacancies and as newer employees are gaining proficiency in their positions, and lower morale among employees dealing with short staffing.

To address structural compensation challenges, MTS conducted a competitive procurement to hire a compensation consultant to conduct an independent compensation study and recommend changes to MTS's pay ranges and practices. A request for proposals was issued on March 15, 2023, and on June 15, 2023 (Agenda Item (AI) 17), the Board of Directors authorized MTS to enter into a six-year contract with The Segal Company ("Segal Co."), a national compensation consulting firm that specializes in public-sector compensation consulting. This agreement with Segal includes the study results presented herein, a subsequent study scheduled for 2028, and the ability to conduct ad-hoc analysis, such as pay equity analysis, to maintain MTS's pay structure through 2028.

#### Salary Structure Background:

Historically, MTS has not made across-the-board pay increases or cost of living adjustments within its unrepresented workforce. Instead, unrepresented employees are eligible for merit pay increases based on their annual performance evaluation, funded from a pool established by the Board of Directors during the annual budget process. MTS's most recent salary surveys in 2012 and 2018 resulted in restructuring MTS's salary ranges in 2012 but no changes were made in 2018. Since 2012, the Board of Directors has approved increases to the maximums of existing ranges as part of the annual budgeting process, but minimums of the pay ranges have remained unchanged resulting in very broad range spreads (distance from range minimum to maximum). Following both surveys, MTS did not make formulaic adjustments to address pay compression; however, adjustments ensured employees were paid at least the newly established minimum salary for their position.

#### Salary Study Methodology:

Segal Co. worked with MTS staff to identify 12 comparable transportation and local government agencies and distributed a survey asking each agency to identify the salary range associated with their matching position for 80 benchmark jobs. Additionally, Segal Co. used three published survey sources which incorporate both public and private sector data to analyze compensation for the benchmark jobs. The impact of published survey data was limited to +/-10% to ensure the resulting comparisons were market-competitive and fiscally responsible given MTS's desire to be a responsible steward of public funds. Segal Co. collected sufficient data to analyze 99% of benchmark jobs. Midpoints of respondent data, along with the average market range spread across benchmark positions, were used to construct a revised salary structure (20 pay grades and associated ranges). Segal Co. placed benchmark jobs in the structure by aligning midpoints of the market data with midpoints of the proposed ranges (and, of course, adjusting for compression with MTS represented positions), while non-benchmark jobs were integrated into the pay structure by analyzing minimum qualifications from job descriptions, among other factors, to ensure a comprehensive and impartial alignment with the overall compensation framework. All 207 unrepresented jobs are included in the proposed pay structure.

#### Summary of findings:

MTS's practice of increasing pay range maximums but not minimums since 2012 resulted in pay ranges with minimum salaries that are not market competitive and pay range spreads that are

much broader than the market average. Competitiveness of pay range maximums varies by position, but the maximum salaries associated with many positions exceeded the market. The proposed new pay structure includes narrower pay ranges to facilitate greater consistency and responsiveness to market. All minimum salaries are increasing, and the average midpoint is increasing by 12%. Maximum pay for 66% of positions is decreasing, but this change will not materially impact employees as few are currently paid within the proposed eliminated range portion.

Proposed Implementation Methodology and Cost:

Employees below the new minimum for their position would have their salaries increased to the minimum effective May 1, 2024. Pay for any employee paid above the maximum for their position will be frozen and any future performance-based pay would be received as a lump sum while the employee remains outside the range maximum.

To address past, and prevent future, pay compression, Segal Co. created a model that places employees in their proposed pay range based on service time in their position. The model calculates what each employee's pay would be had the market-based pay structure been in place in the past. Three key inputs were used to determine the result: (1) Compounding Range Penetration or the percentage increase applied for each year the employee has been in the position, (2) Maximum Range Penetration or the percentage of the maximum salary an employee would be paid (0% is the minimum and 100% is the maximum), and (3) The maximum percentage pay increase any one employee is eligible to receive. If an employee is currently paid at or above the formula's result, their pay would not change as part of the implementation.

When making adjustments in a performance-based system, a common benchmark for determining Compounding Range Penetration is the ten-year average of merit-based pay increases. The rationale for using the ten-year average is that if an employee had been in the market-based pay range for their entire tenure, the resulting calculation would place them appropriately in the pay range. MTS's ten-year merit pool average is 3.3%; however, staff recommend using 2.5% Compounding Range Penetration due to budgetary constraints. Similarly, for budgetary reasons, and to ensure these changes are coordinated with MTS's merit-based pay system, staff recommended a Maximum Range Penetration of 84% and that no single employee will receive a pay increase larger than 25%.

Based on these assumptions and constraints, implementing the revised pay structure effective May 1, 2024, results in a \$2,201,242 increase in base salary cost or 6.25% of covered payroll. The pay of 60% of unrepresented employees would increase as a result of implementation, and the pay of 40% would not increase. While all employees would be paid at or above the minimum pay for their position following implementation, under Section 3.3.2 of MTS Ordinance No. 1 (the Administrative Code and Regulations) the CEO has discretion to make adjustments, subject to the overall budgetary authority requested in this item and future budgets. For example, staff envisions the CEO delaying or reducing pay adjustments for any employee currently performing below established standards or currently subject to a Performance Improvement Plan. We anticipate that use of the CEO's discretion would result in an immaterial reduction in overall cost.

Pay Structure Maintenance:

If approved, the proposed pay ranges will be in place from May 1, 2024, through the end of Fiscal Year 2025 (June 30, 2025). Thereafter, as part of the budgeting process based on relevant market data and guidance from Segal Co., staff will propose increases to the pay ranges on an annual basis for Board approval.

MTS's contract with Segal Co. includes conducting ad-hoc analysis (e.g., position specific, pay equity) and a subsequent salary survey in 2028. Interim analysis directed by staff or the Board may result in recommended incremental changes, but none are planned at this time. The 2028 survey will use the same methodology as this study; however, implementation of the 2028 study is expected to be less costly both because maintaining a market-based structure in the interim will ensure that MTS's pay structure remains competitive and equitable, and because MTS will no longer be increasing only its pay range maximums in response to changing market conditions.

/s/ Sharon Cooney  
Sharon Cooney  
Chief Executive Officer

Key Staff Contact: Sharon Cooney, 619.557.4513, [Sharon.Cooney@sdmts.com](mailto:Sharon.Cooney@sdmts.com)

Attachment: A. Recommended Pay Grades and Ranges Effective May 1, 2024



**Attachment A**  
**Recommended Pay Grades and Ranges Effective May 1, 2024**

<b>Pay Grade</b>	<b>Job Titles</b>	<b>Min</b>	<b>Mid</b>	<b>Max</b>
0	Engineering Intern Intern - Transit Services Operations Assistant - Ride Checker	\$35,048	\$42,408	\$49,768
1	Call/Service Center Representative (FT/PT) Passenger Support Representative Revenue Operations Assistant	\$42,913	\$51,924	\$60,936
2	Administrative Assistant (Copy Center) Administrative Assistant Lead Passenger Support Representative Marketing Assistant Passenger Facilities Coordinator Service Center Specialist (FT) Support Services Coordinator	\$45,058	\$54,521	\$63,983
3	Accounting Assistant Administrative Assistant II Human Resources Assistant Regulatory Inspector Social Media Coordinator	\$47,311	\$57,247	\$67,182
4	(Vacant)	\$49,677	\$60,109	\$70,541
5	Payroll Temp Training Administrator	\$53,154	\$64,317	\$75,479
6	Contract Operations Administrator Customer Service Supervisor Finance Assistant Human Resources Specialist Maintenance Analyst (LRV) Support Services Analyst	\$56,875	\$68,819	\$80,763
7	Assistant Supervisor of Information & Trip Planning Assistant Transit Store Supervisor Buyer Central Control Information Representative Claims Specialist Construction Safety Supervisor Contract Specialist Facilities Supervisor Graphic Designer IT Support Specialist Maintenance Analyst Passenger Support Supervisor Payroll Coordinator Records Specialist Regulatory Analyst Regulatory Assistant Revenue Analyst (Rail)	\$60,856	\$73,636	\$86,416





**Attachment A**  
**Recommended Pay Grades and Ranges Effective May 1, 2024**

Pay Grade	Job Titles	Min	Mid	Max
7	Staff Accountant I Supervisor of Para-Transit Supervisor of Pronto Support Transit Store Supervisor Transportation Service Quality Specialist	\$60,856	\$73,636	\$86,416
8	Associate Transportation Planner Bus Operator Training Instructor Code Compliance Supervisor Community Engagement Specialist Digital Content Developer Dispatch Supervisor - Transit Enforcement Executive Assistant - General Counsel/Asst Board Clerk Executive Assistant Grants Analyst Information & Trip Planning Supervisor LRV Vehicle Communications Specialist Multimedia Designer Operational and Crime Data Analyst Project Administrator Regulatory Inspector Supervisor Senior Scheduler Staff Accountant II Supervisor of Warehouse Operations Training Development Specialist Transit Services Data Analyst Workers' Compensation Analyst	\$66,333	\$80,263	\$94,193
9	Code Compliance Training Supervisor Contracts Administrator Executive Assistant/Clerk of the Board Fare Systems Administrator Financial Analyst Grants Administrator Inventory Planning and Forecasting Analyst Manager of PRONTO & Passenger Support MOW Contracts & Budget Analyst Right of Way Permit Coordinator Security Systems Administrator Senior Contract Operations Administrator Senior Data Analyst Transit Safety Specialist	\$72,303	\$87,487	\$102,671
10	Assignments Supervisor Assistant Manager of Field Operations Benefits & Compensation Analyst Communications and Operations Supervisor Environmental Health & Safety Specialist Liability Claims Supervisor	\$78,811	\$95,361	\$111,911



**Attachment A**  
**Recommended Pay Grades and Ranges Effective May 1, 2024**

Pay Grade	Job Titles	Min	Mid	Max
10	LRV Project Coordinator/Analyst Network Engineer I Payroll Supervisor Procurement Specialist Professional Standards Manager Public Relations Specialist Quality Assurance Inspector Records Manager Report Development Analyst Revenue Operations Manager Senior Accountant Senior Transportation Planner Service Desk Supervisor Service Operations Supervisor Supervisor of Passenger Facilities System Safety Specialist Talent Acquisition Specialist Transportation Controller Transportation Supervisor	\$78,811	\$95,361	\$111,911
11	Assistant Training Supervisor - (LRV/MOW) Bus Maintenance Trainer Central Control Supervisor Creative Design Manager Facilities Foreman Foreman For-Hire Vehicle Administration Lead Transportation Supervisor LRV Maintenance Supervisor Manager of Rail Facilities Manager of Training (Transportation) Manager of Operations-Transit Security & Passenger Safety Network Engineer II Principal Contract Administrator Quality Assurance Supervisor Revenue Maintenance Supervisor Senior Human Resources Analyst Senior Procurement Specialist Systems Administrator Track Supervisor Training Supervisor (Transportation) Transit Asset Management Program Manager Transportation Communication & Technology Supervisor Wayside Maintenance Supervisor	\$87,480	\$105,851	\$124,222
12	Accounting Manager Information Security & Intelligence Engineer	\$97,103	\$117,494	\$137,886



**Attachment A**  
**Recommended Pay Grades and Ranges Effective May 1, 2024**

Pay Grade	Job Titles	Min	Mid	Max
12	Internal Auditor Lead Revenue Maintenance Supervisor Leadership Development Specialist Manager of Inventory Operations Manager of Marketing & Communication Manager of Service Operations Manager of Service Quality & Specialist Manager of Track and Structure Manager of Transportation Communications & Technology Network Engineer III Payroll Manager Project Engineer Senior Systems Administrator Supervisor of Maintenance Training Training Supervisor (LRV/MOW)	\$97,103	\$117,494	\$137,886
13	Business Systems Analyst (SAP) Deputy Director of Transit Security & Passenger Safety IT Enterprise Architect (IoT) Maintenance Division Manager Manager of Benefits & Compensation Manager of Financial Planning Manager of Government Affairs Manager of LRV Maintenance Manager of MOW Manager of Paratransit & Mini Bus Manager of Procurement Manager of Rail Transportation Manager of Risk and Claims Manager of Safety (Bus) Manager of Scheduling Manager of Talent Acquisition Project Manager SAP Software Developer Software Developer Senior Data Warehouse Engineer System Safety Manager (Rail) Technical Project Manager Transportation Division Manager ZEV and Sustainability Manager	\$107,784	\$130,419	\$153,053
14	Director of Fare Technology & Operations Director of Support Services Information Security Manager IT Development Manager IT Operations Manager Manager of Real Estate Assets Network Operations Manager	\$119,640	\$144,765	\$169,889



**Attachment A**  
**Recommended Pay Grades and Ranges Effective May 1, 2024**

<b>Pay Grade</b>	<b>Job Titles</b>	<b>Min</b>	<b>Mid</b>	<b>Max</b>
14	Senior Project Manager	\$119,640	\$144,765	\$169,889
15	Deputy General Counsel Director of Planning & Scheduling Director of Contract Services Director of Supply Chain & Operations	\$132,801	\$160,689	\$188,577
16	Director Marketing & Communications Director of Fleet & Facility Maintenance Director of Human Resources Director of LRV Maintenance Director of MOW Director of Rail Facilities	\$147,409	\$178,365	\$209,320
17	Controller Director of Financial Planning & Analysis Director of Rail Transportation Director of Transit Security & Passenger Safety Director of Capital Projects Director of Transportation	\$163,624	\$197,985	\$232,346
18	(Vacant)	\$181,622	\$219,763	\$257,904
19	Chief Human Resources Officer Chief Information Officer General Counsel	\$201,601	\$243,937	\$286,273
20	Chief Financial Officer Chief Operating Officer-Transit Services Chief Operating Officer (Rail)	\$223,777	\$270,770	\$317,763
21*	Chief Executive Officer	\$350,000	\$350,000	\$350,000

\* job not included in study



# San Diego Metropolitan Transit System (MTS)

## Independent Salary Survey

**Executive Committee Presentation, April 11, 2024**

*TL Cox*  
*Vice President*



# Agenda

- About Segal
- Project Introduction and Methodology
- Findings
- Implementation
- Questions?

# About Segal

# Company Background

- Segal is a national consultancy offering services and advice related to **classification, compensation, benefits, and human resources**.
  - Founded in 1939
  - Independent, privately-held
  - 24 office locations with approximately 1,000 employees
- Our consulting team has a **strong background** in conducting research and providing customized recommendations and advice regarding:
  - Market benchmarking
  - Pay system design
  - Classification structure analysis
  - Job evaluation (internal equity)
  - Performance management
  - Pay equity
  - Cost modeling
  - Employee communication
  - Union-management facilitation
- We have served as trusted advisors for many public sector entities, **including several throughout California and nationally within the transit/transportation vertical.**



# California and Industry Presence

- Segal has served the public sector in California since the 1960s
- Active projects with a number of large, public employers in the state
- **Recent experience includes:**
  - Metrolink
  - Bay Area Rapid Transit
  - Santa Clara County
  - Santa Clara Valley Transportation Authority
  - San Joaquin County
  - Sonoma County
  - Marin County
  - Superior Court of California, County of Los Angeles
  - City of Anaheim
  - San Joaquin Council of Governments



# Project Introduction and Methodology

# Market Survey Process

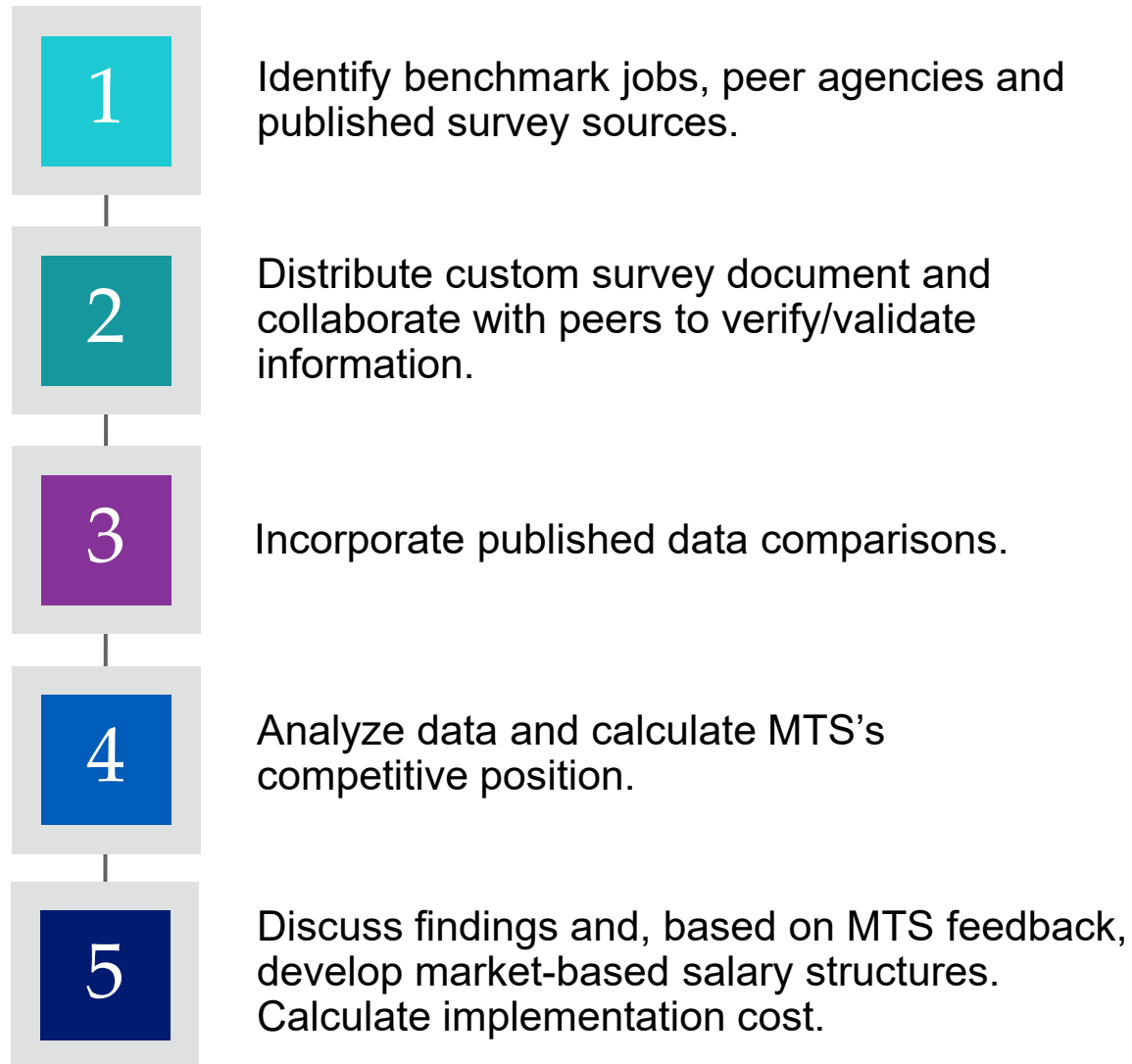

# Key Deliverables



## Project Initiation

Stakeholder interview themes, survey process tailored to MTS's unique needs and operating environment.



## Base Salary Market Assessment

Public and private sector benchmarking, comparisons by peer, job title, etc.



## Salary Structure(s)

New salary structure(s) reflecting the market data collected.



## Implementation

Implementation guidance and costing based on MTS-defined goals. Process for future, data-driven decisions regarding pay range movement and grade placement.

# Criteria for Peer Agency Selection

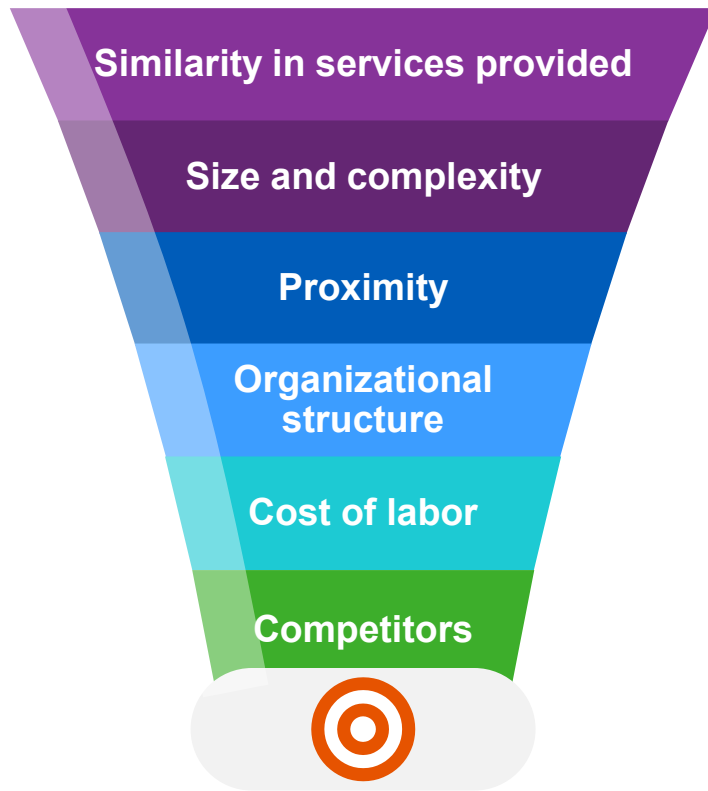

- 1 | Organizations most likely to have matching jobs are those that provide similar or overlapping services, and structure pay accordingly.
- 2 | Organizations similar in size and complexity are likely to have a broad enough employee base for meaningful comparisons.
- 3 | Across many positions, those most likely to work for MTS will be in proximity to the work that needs to be performed. Organizations often, therefore, make policy decisions regarding how competitive they must be to recruit and retain employees within these job classifications.
- 4 | Similar organizational structures are most likely to have jobs that can be accurately matched based on content (core functions and minimum qualifications).
- 5 | Because the cost of labor will most certainly differ across regions, it's important to use geographic differentials to ensure credible comparisons.
- 6 | Once you've identified organizations that meet some (though not necessarily all) criteria, it's critical that they include historical competitors for the recruitment and retention of talent.

# Peer Agencies

California Transit Agencies	California Cities	Other
Los Angeles County Transportation Authority	City of Chula Vista	King County Metro Transit (Washington)
San Francisco Municipal Transportation Agency	City of San Diego	San Diego Association of Governments
North County Transit District		Utah Transit Authority
Orange County Transportation Authority		
Sacramento Regional Transportation District		
Tri-County Metropolitan Transportation District of Oregon*		
Valley Transportation Authority		

Segal received responses from or collected data on behalf of 11 of 12 peers (~92%)

\* denotes non-responsive peer.

# Geographic Adjustments

To adjust for geographic differences in the cost-of-labor between the peer locations and San Diego (as appropriate) Segal used indices reported by the Economic Research Institute (ERI) as of October 1, 2023, for the 25-mile radius around each peer location.

Peer Agency	Cost of Labor Comparison to San Diego, California <sup>1</sup>	Differential Applied
City of Chula Vista, CA	100.0%	0.0%
City of San Diego, CA	100.0%	0.0%
King County Metro Transit (Seattle, WA)	95.9%	-4.1%
Los Angeles County Transportation Authority (Los Angeles, CA)	96.6%	-3.4%
Municipal Transportation Agency (San Francisco, CA)	87.0%	-13.0%
North County Transit District (San Diego, CA)	100.0%	0.0%
Orange County Transportation Authority (Orange, CA)	97.4%	-2.6%
Sacramento Regional Transportation District (Sacramento, CA)	99.2%	-0.8%
San Diego Association of Governments	100.0%	0.0%
Utah Transit Authority (Salt Lake City, UT)	114.6%	14.6%
Valley Transportation Authority (Santa Clara, CA)	86.5%	-13.5%

# Published Survey Sources

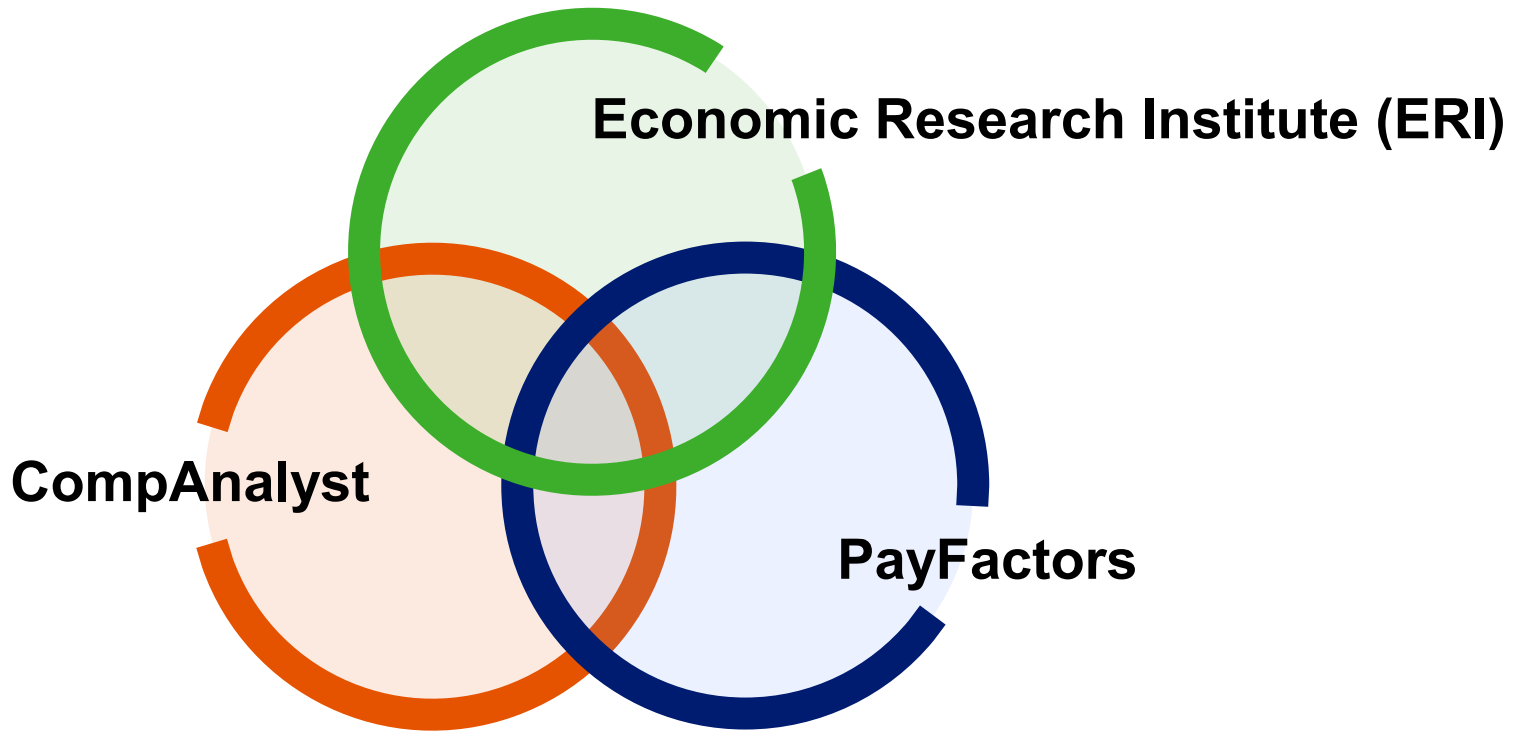



# Findings

# External Comparisons



- 81 benchmark job titles were included in the custom survey document developed by Segal.
- Matches were based on the documentation and analysis of job descriptions and organizational data provided by MTS.
- Published survey data was incorporated from reputable sources. To minimize published data disproportionately influencing custom, public sector peer averages, published data impacts were limited to +/- 10%.
- Market averages were calculated and compared to existing pay range minimums, midpoints, and maximums.

# Survey Responses Summarized

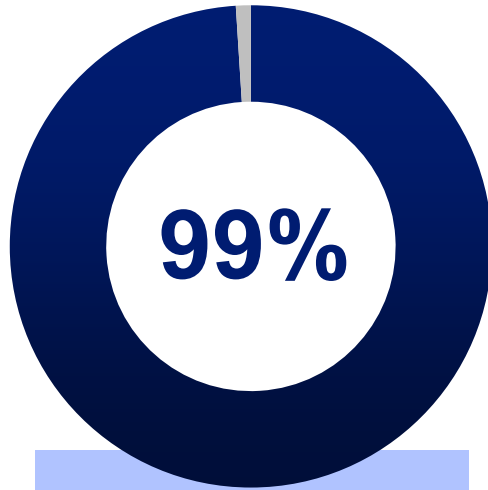

Benchmark jobs with sufficient market data for comparisons

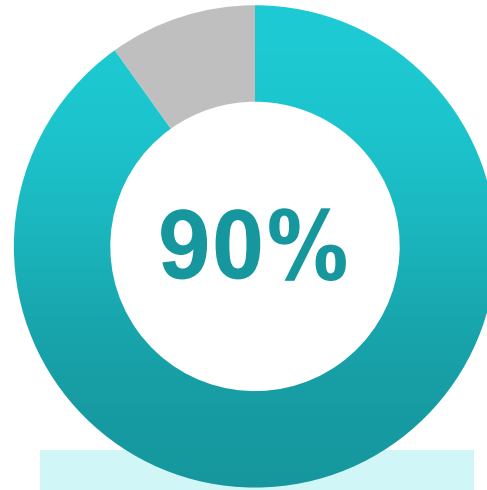

Benchmark jobs with at least one published survey comparison

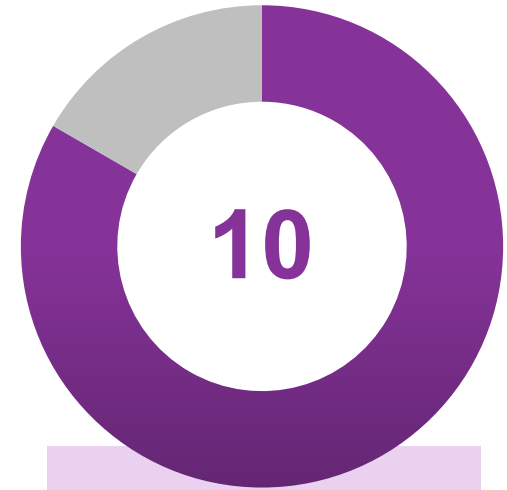

Average number of matches across all benchmark jobs

# Competitiveness Varies by Job Title

At Pay Range Midpoint/Rate	Benchmark Jobs
Above Market	3
Below Market	49
Insufficient Data	1
Market Competitive	27

Overall competitiveness of MTS's wages varies from 64% to 112% of market.

# Base Pay

## MTS as a % of Overall Market Average

	Base Pay Range		
	Minimum	Midpoint	Maximum
Custom Survey Peers	71%	90%	105%
Published Data Sources	76%	88%	93%
<b>Overall Market Average</b>	<b>73%</b>	<b>91%</b>	<b>104%</b>

Across all jobs, we found MTS to be below both custom peer agencies and the published data sources (representing the private sector) at the pay range minimum and midpoint. Competitiveness at the pay range maximum varied by sector but was generally market competitive on an overall basis.

# Base Pay – By Peer Organization

MTS Base Pay as a % of Peer Market Average

Peer Organization	Count of Matches	Pay Range Minimum	Pay Range Midpoint	Pay Range Maximum
City of Chula Vista, CA	38	74%	97%	123%
City of San Diego, CA	39	95%	106%	113%
King County Metro Transit	59	64%	87%	104%
Los Angeles County Transportation Authority	66	75%	93%	105%
Municipal Transportation Agency	71	62%	82%	100%
North County Transit District	55	81%	93%	101%
Orange County Transportation Authority	62	82%	89%	118%
Sacramento Regional Transportation District	62	73%	92%	106%
San Diego Association of Governments	45	72%	86%	95%
Utah Transit Authority	40	74%	92%	105%
Valley Transportation Authority	68	68%	92%	115%

Results varied by peer, but the MTS pay range was generally below market at the minimum and midpoint and either at or above market at the pay range maximum.

# Implementation

# Salary Structure Development

## Purpose

A salary structure defines ranges of pay for jobs within an organization and helps manage:

- Minimum and maximum rates of pay
- Progression of jobs within a career family and across disciplines and work groups
- The desired position relative to market

## Methodology

- Market data is used as a reference by aligning the average to the midpoint of each grade. Pay range minimums and maximums are determined by average market range spreads.
- Jobs are assigned to the grade with the midpoint closest to the market average to ensure competitiveness.



# Salary Structure Development *(continued)*

## **Strategic Design of New Pay Ranges**

MTS's existing spreads were much broader than market, meaning that starting salary offers, placement of current incumbent(s), and the pay range itself may not be wholly competitive with other agencies.

- Segal reviewed range spreads for different types and levels of jobs throughout MTS and concluded that a single compensation plan would enable greater responsiveness to current market conditions.
- Some limited jobs, therefore, may reflect increased competitiveness at the pay range minimum and midpoint, but lower market maximums. This does not have a meaningful impact to MTS staff because employees have not historically penetrated their ranges that far (due to lower range minimums).
- Moreover, when increasing pay range minimums to be more competitive, it's important to consider time-in-position adjustments for current staff to avoid, to the extent possible, salary compression among incumbents with varying degrees of tenure or seniority within their existing job classification.

# Salary Structure Development *(continued)*

## Grade Placement

Segal recommended the initial placement of all job titles within scope.

- Internal stakeholders then provided feedback, which was vetted by MTS leadership and HR.
- Changes internally-supported by MTS were submitted to Segal for final review and consideration.
- Reviewing existing job descriptions and the market data collected, along with best or prevailing practices, Segal provided MTS with the final salary structures and grade assignment.

## Implementation

MTS sought Segal's guidance on implementing the recommendations. Segal suggests the following implementation plan:

- Any employee below their new range minimum should be given an increase sufficient to reach the new range minimum as soon as feasible.
- To avoid compression potentially created by the strategic design of MTS's new structure, Segal has provided a model that calculates time in position implementation scenarios.

# Compression and Equity Adjustment Variables

Compounding Range  
Penetration

2.5%

Maximum Range  
Penetration

84%

Maximum Percentage  
Increase

25%

# Cost Breakout

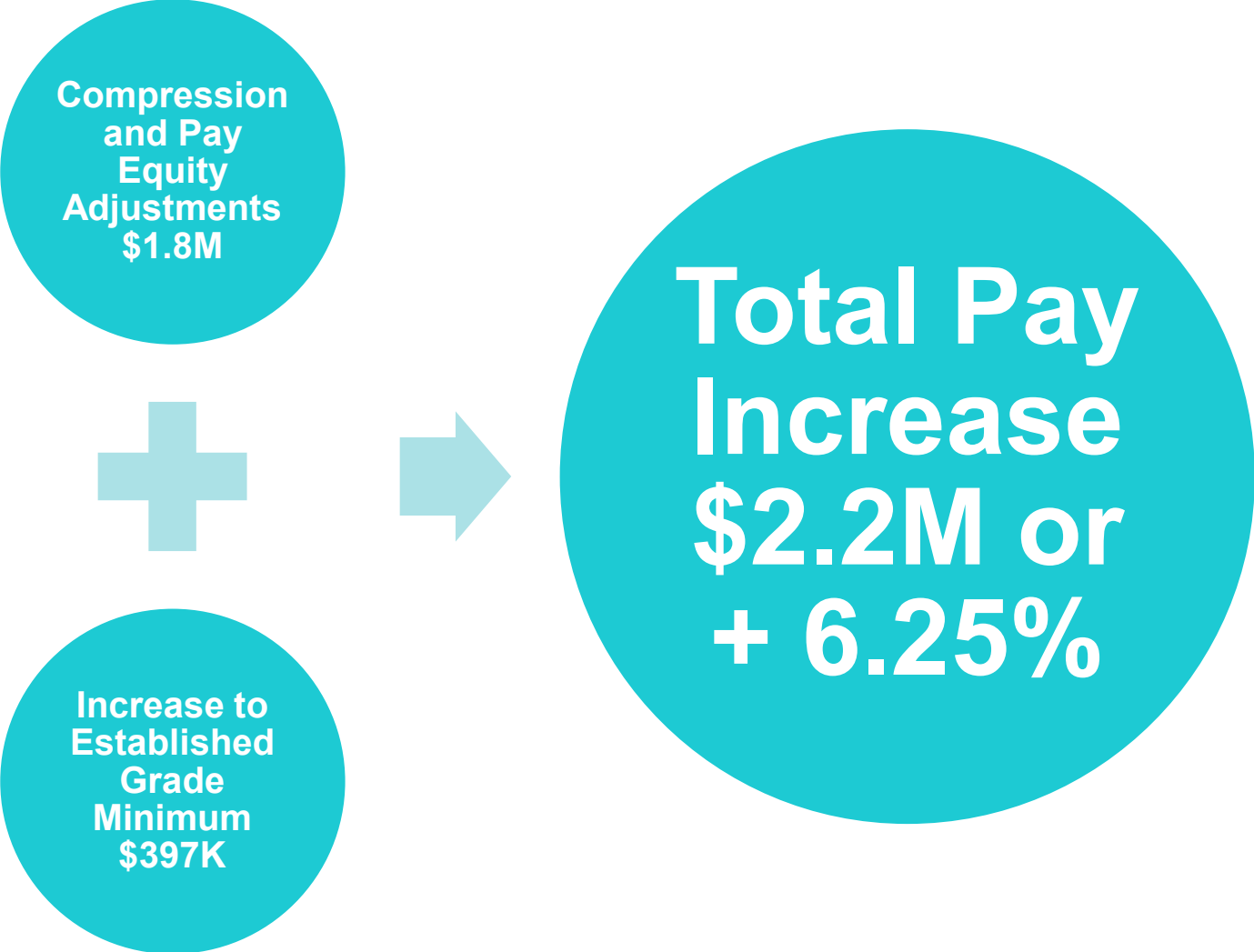

# Distribution of Implementation Costs

- The majority of implementation costs are applied to incumbents assigned to grades 13 and below

Grade	Employees receiving Increase	Increase Amount
Grades 0-6	51 of 79 (65%)	\$247,430
Grades 7-13	182 of 302 (60%)	\$1,697,424
Grades 14-20	13 of 32 (41%)	\$256,389
<b>Total</b>	<b>246 of 413 (60%)</b>	<b>\$2,201,242</b>

Employees Receiving Implementation Increase by Grade

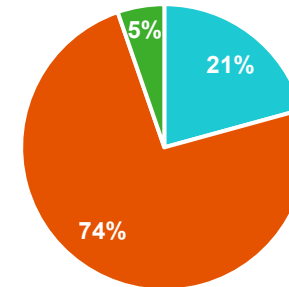

Grades 0-6   Grades 7-13   Grades 14-20

Distribution of Implementation Cost by Grade

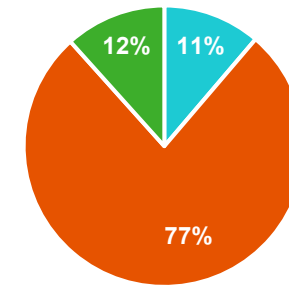

Grades 0-6   Grades 7-13   Grades 14-20

# Compensation (Compa.) Ratio

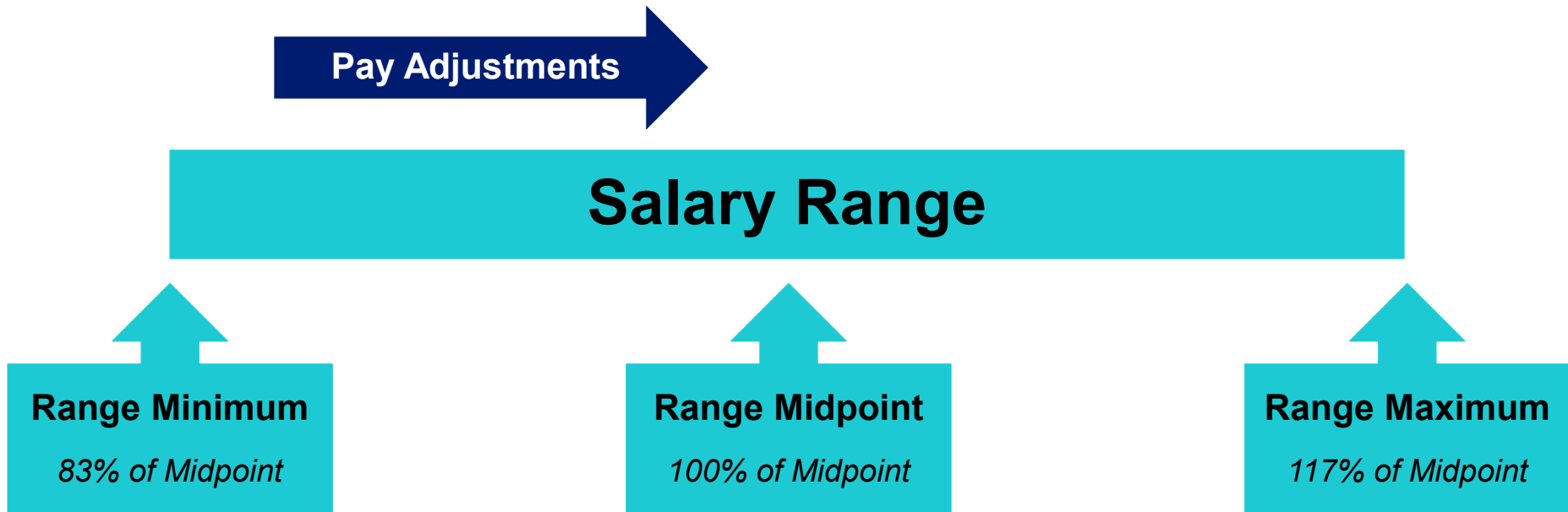

***Compa. Ratio = Employee Salary / Salary Range Midpoint***

**Proposed compression and equity adjustments increase MTS's average compa. ratio from 89% to 95%.**

# Pay Increase Distribution by Org. Level

Individual Contributors

37%

Frontline Supervisors

54%

Management

9%

# Relevant Statistics

## Population statistics

- 60% of employees' pay will increase – 40% will not
- 60% of employees' range maximums are decreasing
- 91% of employee's range midpoints are increasing
- 86% of employees who are receiving a pay increase earn less than \$100,000
- 66% of employees who are receiving a pay increase make less than \$85,000
- 27% of employees who are receiving a pay increase make less than \$65,000

## Individual employee statistics

- Largest percentage increase is 25%
- Median pay increase is \$7,757/Yr.
- Average pay increase is \$8,948/Yr.
- Largest pay increase is \$37,580/Yr.
- Average percentage increase is 13.2%



Questions?



Board of Directors
Agenda

April 25, 2024 at 9:00 a.m.

In-Person Participation: James R. Mills Building, 1255 Imperial Avenue, 10th Floor Board Room, San Diego CA 92101

Teleconference Participation: (669) 444-9171; Webinar ID: 982 8803 2362, https://zoom.us/j/98288032362

Table with 3 columns: NO., ITEM SUBJECT AND DESCRIPTION, ACTION. Contains 6 items including Roll Call, Public Comments, and various contract amendments.



- 7. Increased Authorization for Legal Services Contract to Pay Projected Expenses in Fiscal Year 2025 – Contract Amendment** Approve

Action would: 1. Ratify Amendment 9 to MTS Doc. No. G2202.0-19, with Meyers Nave, in the amount of \$150,000.00; and 2. Authorize the Chief Executive Officer (CEO) to execute Amendment 10 to MTS Doc. No. G2202.0-19, with Meyers, in the amount of \$600,000.00.
- 8. Imperial Avenue Division (IAD) Overhead Charging System – Contract Award** Approve

Action would authorize the Chief Executive Officer (CEO) to execute MTS Doc. No. B0761.0-24 with Heliox Technology North America, LLC (Heliox) for the provision of the IAD overhead charging system, for a term of five (5) years, for a total of \$3,358,171.90.
- 9. Railroad Ties – Contract Award** Approve

Action would authorize the Chief Executive Officer (CEO) to execute MTS Doc. No. L1663.0-24 with Balfour Beatty Infrastructure, Inc. (Balfour), in the amount of \$167,475.00 for the purchase of railroad ties.
- 10. Hewlett Packard Enterprise (HPE) Synergy for Operations Control Center (OCC) Data Center – Contract Award** Approve

Action would authorize the Chief Executive Officer (CEO) to execute MTS Doc. No. G2833.0-24 with Nth Generation Computing, Inc. (Nth), effective for five (5) years, for the purchase of HPE Synergy equipment, software, and support/ services in the amount of \$283,820.08.
- 11. Occupational Health Services – Contract Award** Approve

Action would: 1) Authorize the Chief Executive Officer (CEO) to execute MTS Doc. No. G2887.0-24 with Concentra Medical Centers (Concentra), to provide occupational health services for a five (5) year base period with five (5) 1-year options, a total of ten (10) years, for a total contract cost of \$1,114,128.00; 2) Authorize the CEO to execute MTS Doc. No. G2888.0-24 with Kaiser On-the-Job (Kaiser), to provide occupational health services for a five (5) year base period with five (5) 1-year options, a total of ten (10) years, for a total contract cost of \$1,351,200; and 3) Exercise options years at the CEO's discretion.
- 12. Variable Messaging Sign (VMS) Media Converter & Cradlepoint Hardware – Contract Award** Approve

Action would authorize the Chief Executive Officer (CEO) to execute MTS Doc. No. G2839.0-24 with Datel Systems Incorporated (Datel), effective for five (5) years, for the purchase of network equipment, in the amount of \$402,481.00.

- 13. Iris Rapid Transit Center East and Bus Stops Construction - Contract Award** Approve  
Action would authorize the Chief Executive Officer (CEO) to: 1) Execute MTS Doc. No. PWB380.0-24 with Hazard Construction Engineering LLC (Hazard Construction), for the Iris Rapid Transit Center East and Bus Stops Construction in the amount of \$4,410,884.00; and 2) Authorize the CEO to execute amendments or change orders up to a 15% contingency or \$661,632.60 for this construction contract, bringing total expenditure authority to \$5,072,516.60.
- 14. Design Services for Iris Rapid Route and Station Infrastructure Improvements – Work Order Amendment** Approve  
Action would: 1) Ratify Work Order WOA353-AE-19, under MTS Doc No. PWL353.0-22 (Attachment A), with Dokken Engineering (Dokken), in the amount of \$111,611.05 to provide additional project management, new bid package development and support services, additional design support during construction, and prepare as-built drawings; 2) Ratify Work Order WOA353-AE-19.01, under MTS Doc No. PWL353.0-22 with Dokken, in the amount of \$16,813.67 to provide temporary construction easement extensions; and 3) Authorize the Chief Executive Officer (CEO) to approve Amendment WOA353-AE-19.02, under MTS Doc No. PWL353.0-22 with Dokken, in the amount of \$117,746.82 to provide additional project management, local agency processing, fiber optic design and San Diego Gas & Electric (SDG&E) coordination, bid package preparation and bid support, design support during construction, and as-built drawings.
- 15. Iris Rapid Transit Center East and Bus Stops Construction Management (CM) Services - Award Work Order Agreement** Approve  
Action would authorize the Chief Executive Officer (CEO) to execute Work Order No. WOA2498-CM19 under MTS Doc. No. G2498.0-21 with Kleinfelder Construction Services, Inc. (KCS), totaling \$900,510.13 for CM services for the Iris Rapid Project.
- 16. Building B Office Improvements – Work Order Agreement** Approve  
Action would authorize the Chief Executive Officer (CEO) to execute Work Order No. MTSJOC324-48 under Job Order Contract (JOC) to MTS Doc. No. PWG324.0-21 with ABC General Contractor, Inc. (ABCGC), in the amount of \$220,792.67 for the improvements of Revenue Area, Pay Station Service Room, Facility Offices and Break Room areas at Building B.
- 17. El Cajon Third Track Construction Management (CM) Services – Work Order Amendment** Approve  
Action would authorize the Chief Executive Officer (CEO) to execute Work Order Amendment No. WOA2498-CM02.02 under MTS Doc. No. G2498.0-21 with Kleinfelder Construction Services, Inc. (KCS), for the El Cajon Third Track and El Cajon Third Track –Interlocking E26 CM services in the amount of \$411,792.40.

18. **Commercial Tenant Relocation and Property Management Services - Clean Transit Advancement Campus (CTAC) – Work Order Agreement** Approve  
Action would authorize the Chief Executive Officer (CEO) to execute Work Order WOA357-AE-39 under MTS Doc. No. PWL357.0-22 (in substantially the same format as Attachment A), with Chen Ryan Associates, Inc. (CRA), a Disadvantaged Business Enterprise (DBE), in the amount of \$533,448.30 to provide tenant relocation and property management services for the CTAC project.
19. **State of California Office of Emergency Services – Designation of Applicant Agent Resolution** Approve  
Action would: 1) Authorize the Chief Executive Officer (CEO) and designee(s) to serve as MTS’s agent to engage with the Federal Emergency Management Agency and the Governor’s Office of Emergency Services regarding all matters pertaining to Federal financial assistance and/or State financial assistance under the California Disaster Assistance Act; and 2) Authorize the Chair of the Board of Directors to sign the Designation of Applicant’s Agent Resolution for Non-State Agencies Form (CalOES Form 130) (Attachment A).
20. **Improving Restroom Availability at San Diego State University Transit Center - Memorandum of Understanding Amendment** Informational
21. **Fiscal Year (FY) 2025 Capital Improvement Program (CIP) Amendment** Approve  
Agenda Item will be provided prior to Board Meeting.
22. **ChargePoint ViriCiti Bus Telematics License Renewal-Sole Source Contract Award** Approve  
Agenda Item will be provided prior to Board Meeting.

DISCUSSION AND REPORT ITEMS

23. **Independent Salary Study Results – Implementation of Recommended Pay Grades and Ranges**  
Agenda Item will be provided prior to Board Meeting.
24. **Draft FY 2025 Operating Budget**  
Agenda Item will be provided prior to Board Meeting.
25. **Naming Rights – UCSD**  
Agenda Item will be provided prior to Board Meeting.

OTHER ITEMS

26. **Chair, Board Member and Chief Executive Officer’s (CEO’s) Communications and CEO Report** Informational
27. **Remainder of Public Comments Not on The Agenda**  
This item is a continuation of item No. 2 (Public Comment), in the event all speakers who request to comment on item No. 2 are not called. If all Public

Comment is accepted during item No. 2, no additional public comment will be accepted under this item.

#### ADJOURNMENT

**28. Next Meeting Date**

The next Board of Director's meeting is scheduled for May 16, 2024 at 9:00 a.m.

**29. Adjournment**

DRAFT



**Metropolitan  
Transit  
System**

**DRAFT FOR EXECUTIVE COMMITTEE REVIEW DATE: 4/11/2024**

**Agenda Item No. 4**

MEETING OF THE SAN DIEGO METROPOLITAN TRANSIT SYSTEM  
BOARD OF DIRECTORS

April 25, 2024

**SUBJECT:**

Mobile Security Trailers – Sole Source Contract Amendment

**RECOMMENDATION:**

That the San Diego Metropolitan Transit System (MTS) Board of Directors authorize Chief Executive Officer (CEO) to execute MTS Doc. No. G2755.1-23 (in substantially the same format as Attachment A), with Monmouth Solutions, Inc., a Service-Disabled Veteran Owned Small Business (SDVOSB), in the amount of \$98,055.00 to change the contract from leasing to purchasing the mobile security trailers.

Budget Impact

The total cost of this amendment is estimated to be \$98,055.00, and the total contract cost of the contract is estimated to be \$206,000.00. This project will be funded by the Capital Improvement Project (CIP) account 1009116701-599907.

**DISCUSSION:**

On June 5, 2023, MTS issued an Invitation for Bids (IFB) on PlanetBids for the fabrication, delivery, and set up of up to five (5) security trailers at various MTS transit locations for a three (3) year period. MTS received a total of four (4) bids on the due date of July 6, 2023 from the following bidders:

Bidder Name	Certifications	Total Bid Amount*
Bert's Office Trailers, Inc.	N/A	\$51,652.80
Monmouth Solutions, Inc.	SDVOSB	\$107,945.00
Aries Building Systems, LLC	N/A	\$237,792.44
Morgan Inglad LLC	N/A	\$301,135.63

\*Bid is inclusive of CA sales tax (7.750%)

Bert's Office Trailers, Inc. and Morgan Inglad LLC were both deemed non-responsive. Bert's Office Trailers was deemed non-responsive as they did not submit a cost proposal for all five (5)



trailers outlined in the scope of work. Morgan England was also deemed non-responsive as they did not submit any of the required MTS forms in their bid submittal. Monmouth Solutions was deemed to be the lowest responsive and responsible bidder.

On August 22, 2023, under the CEO's signature authority, MTS executed MTS Doc. No. G2755.0-23 with Monmouth Solutions, Inc. for a total contract cost of \$107,945.00 for the purchase of up to five (5) security trailers at various MTS locations for a three (3) year period.

The first two (2) trailers were delivered in February 2024. MTS subsequently installed various information technology systems and equipment to make the trailers ready for MTS security operations. However, upon processing of the payment invoices for the trailers, staff was made aware that Monmouth was under the assumption that the trailers were being leased not purchased. After meeting with Monmouth, staff confirmed there had been a miscommunication. To avoid affecting operations, Monmouth has agreed to lease the two (2) trailers on-site for a total of three (3) months. After the three (3) month period, MTS will purchase the five trailers initially outlined in the contract. The total cost of the lease and purchase of the trailers is \$206,000.00. The total cost remains lower than the second responsible and responsive bidder (Aries Building Systems, LLC); therefore, staff deemed Monmouth's pricing to be fair and reasonable.

Therefore, staff recommends that the MTS Board of Directors authorize the CEO to execute MTS Doc. No. G2755.1-23 (in substantially the same format as Attachment A), with Monmouth Solutions, Inc. in the amount of \$98,055.00 to change the contract from leasing to purchasing the mobile security trailers.

/s/ Sharon Cooney  
Sharon Cooney  
Chief Executive Officer

Key Staff Contact: Julia Tuer, 619.557.4515, [Julia.Tuer@sdmts.com](mailto:Julia.Tuer@sdmts.com)

Attachment: A. Draft Agreement, MTS Doc. No. G2755.1-23





# Metropolitan Transit System

## Amendment 1

March 11, 2024

MTS Doc No. G2755.1-23

### MOBILE TRAILERS

Monmouth Solutions, Inc.  
 Anthony Farelli  
 Sales Coordinator  
 93 Butman Road  
 Lowell, MA, 01852

This shall serve as Amendment No.1 to the original agreement G2755.0-23 as further described below.

### SCOPE

Pursuant to the Scope of Work, MTS will lease one (1) breakroom trailer and one (1) mobile trailer for a period of three (3) months. After the three-month period, MTS will purchase both trailers. During the term of the contract, MTS may purchase up to a total of five (5) trailers.

### SCHEDULE

There shall be no change to the schedule of this contract.

### PAYMENT

This contract amendment shall authorize additional costs not to exceed \$98,055.00. Cost form shall be amended as follows:

Item	Description	Months	Unit Price	Extended Price
1	Breakroom Trailer 8' x' 16' – Lease	3	\$500.00	\$1,500.00
2	Mobile Office Trailer 10' x 28' – Lease	3	\$500.00	\$1,500.00
<b>Total Cost for 2-month lease</b>				<b>\$3,000.00</b>

Item	Description	Quantity	Unit Price	Extended Price
1	Breakroom Trailer 8' x' 16' – Purchase (Refurbished)	1	\$40,000.00	\$40,000.00
2	Mobile Office Trailer 10' x 28' – Purchase (Refurbished)	1	\$40,000.00	\$40,000.00
3	Breakroom Trailer 8' x' 16' – Purchase (New)	3	\$41,000.00	\$123,000.00
<b>Total Cost - Purchase</b>				<b>\$203,000.00</b>

<b>Grand Total</b>				<b>\$206,000.00</b>
--------------------	--	--	--	---------------------

1255 Imperial Avenue, Suite 1000, San Diego, CA 92101-7490 • (619) 231-1466 • sdmts.com

San Diego Metropolitan Transit System (MTS) is a California public agency comprised of San Diego Transit Corp., San Diego Trolley, Inc. and San Diego and Arizona Eastern Railway Company (nonprofit public benefit corporations). MTS member agencies include the cities of Chula Vista, Coronado, El Cajon, Imperial Beach, La Mesa, Lemon Grove, National City, Poway, San Diego, Santee, and the County of San Diego. MTS is also the For-Hire Vehicle administrator for nine cities.



The total value of this contract, including this amendment, shall be in the amount of \$206,000.00. This amount shall not be exceeded without prior written approval from MTS.

Please sign and return the copy to the Contract Specialist at MTS. All other terms and conditions shall remain the same and in effect. Retain the other copies for your records.

Sincerely,

Agreed:

\_\_\_\_\_  
Sharon Cooney, Chief Executive Officer

\_\_\_\_\_  
Anthony Farelli, Sales Coordinator  
Monmouth Solutions, Inc.

Date: \_\_\_\_\_

DRAFT



**Metropolitan  
Transit  
System**

**DRAFT FOR EXECUTIVE COMMITTEE REVIEW DATE: 4/11/2024**

## **Agenda Item No. 5**

MEETING OF THE SAN DIEGO METROPOLITAN TRANSIT SYSTEM  
BOARD OF DIRECTORS

April 25, 2024

**SUBJECT:**

Siemens: Orange Line Improvement Project – Sole Source Contract Award

**RECOMMENDATION:**

That the San Diego Metropolitan Transit System (MTS) Board of Directors authorize the Chief Executive Officer (CEO) to execute MTS Doc. No. L1670.0-24 (in substantially the same format as Attachment A), a sole source award to Siemens Mobility, Inc. (Siemens), in the amount of \$427,222.03 for the purchase of Siemens signal instrument components for the Orange Line Improvement Project.

Budget Impact

The total contract cost of materials is estimated to be \$427,222.03 (Attachment B). The project will be funded by the Capital Improvement Program (CIP) account 2005119501 – Orange Line Rail Signals.

**DISCUSSION:**

The Orange Line Improvement Project will make trolley system improvements at various locations within the 17.6-mile line, benefitting the cities of San Diego, Lemon Grove, La Mesa, and El Cajon. The Project goal is to increase train speeds, improve service reliability and operating flexibility, maintain grade crossing safety, and increase the State of Good Repair (SGR).

Phase 1 of the Project will upgrade the signal system and grade crossing warning systems to support bi-directional running between 32<sup>nd</sup>/Commercial Station and Massachusetts Avenue Station. The Orange Line Automatic Block Signal (ABS) system was originally built for unidirectional running with the grade crossing warning systems monitoring trains approaching the crossing in the normal direction of traffic. Trains operating reverse current of traffic must do so under a set of rules that significantly reduce efficiency. Trains must operate at restricted speed, which limits the Maximum Authorized Speed (MAS) to 20 miles per hour. Trains must stop one car length approaching each grade crossing to activate the warning system and then proceed once the gates are in the down position.



The Project will also improve MTS's SGR. Signal instrument shelters and the associated equipment within this area are approximately 35 years old, have served their useful life, and need upgrading. These upgrades will improve the overall reliability, performance, and maintenance of the Orange Line.

Due to long lead time for some equipment, MTS has decided to procure ahead of time the Phase Shift Overlay (PSO) 4000 crossing assembly, PSO 4000 transceiver assembly, and PSO 4000 transmitter assembly, which are used to detect trains for the grade crossing warning systems.

Today's proposed action awards a sole source contract to Siemens for the purchase of these highly specialized components. These parts are only available from Siemens, who is the original manufacturer. Siemens has provided pricing for each component, including lead time for deliveries. Staff has performed a cost/price analysis and deemed the cost to be fair and reasonable based on past purchase history and in comparison to the MTS Independent Cost Estimate (ICE) (\$498,882.40).

Therefore, staff recommends that the MTS Board of Directors authorize the CEO to execute MTS Doc. No. L1670.0-24 (in substantially the same format as Attachment A), a sole source award to Siemens, in the amount of \$427,222.03 for the purchase of Siemens signal instrument components for the Orange Line Improvement Project.

/s/ Sharon Cooney  
Sharon Cooney  
Chief Executive Officer

Key Staff Contact: Julia Tuer, 619.557.4515, [Julia.Tuer@sdmts.com](mailto:Julia.Tuer@sdmts.com)

Attachments: A. Draft Agreement, MTS Doc. No. L1670.0-24  
B. Quote



# Metropolitan Transit System

**STANDARD AGREEMENT  
FOR  
SIEMENS - ORANGE LINE IMPROVEMENT PROJECT  
MTS DOC. NO. L1670.0-24**

THIS AGREEMENT is entered into this \_\_\_\_\_ day of \_\_\_\_\_, 2024 in the State of California by and between San Diego Metropolitan Transit System ("MTS"), a California public agency, and the following, hereinafter referred to as "Contractor":

Name: Siemens Mobility, Inc. Address: 5301 Price Avenue  
McClellan CA 95652  
 City State Zip  
 Form of Business: Corporation  
 (Corporation, Partnership, Sole Proprietor, etc.) Email: [Reiner.G.Martin@siemens.com](mailto:Reiner.G.Martin@siemens.com)  
 Telephone: (916) 273-2960

Authorized person to sign contracts	<u>Martin Reiner</u>	<u>Director of Rail Services</u>
	Name	Title

The Contractor agrees to provide goods as specified in the conformed Contractor's Quote (Exhibit A), and in accordance with the Standard Agreement, including Standard Conditions (Exhibit B), and signed MTS Forms (Exhibit C).

The contract is effective from May 1, 2024 to August 31, 2024. Delivery of all orders must be shipped in a timely manner. The lead time is shown in Exhibit B.

Payment terms shall be net 30 days from invoice date. The total contract cost shall not exceed \$427,222.03 without the express written consent of MTS.

SAN DIEGO METROPOLITAN TRANSIT SYSTEM	SIEMENS MOBILITY, INC.
By: _____ Sharon Cooney, Chief Executive Officer	By _____ Title: _____
Approved as to form: By: _____ Karen Landers, General Counsel	



Cust Document No  
11247-1

Sales Group-Quotation No MMR - 11247-0	Date 3/14/2024
---	-------------------

Quotation No  
11247-0

Quotation Date  
2/5/2024

Validity Period  
3/14/2024 - 6/12/2024

Customer No  
30027236

Page 1 of 1

**Sold To:**

SAN DIEGO TROLLEY INC  
1255 IMPERIAL AVE  
SAN DIEGO CA 92101-7493 US

**Ship To:**

SAN DIEGO TROLLEY INC  
1255 IMPERIAL AVE  
SAN DIEGO CA 92101-7493 US

**Bill To:**

SAN DIEGO TROLLEY INC  
1255 IMPERIAL AVE  
SAN DIEGO CA 92101-7493 US

Shipping is included in Unit Price.

Line Item	Material Number/Description	Qty	Unit Price USD	Total Price USD
10	NYK:70007A4740001 PSO4000 XING MOD Lead time: 13 weeks	26.00 PC	8,282.01	215,332.26
20	NYK:70007A4750001 TRANSCIVER ASSEMBLY, PSO 4000 Lead time: 13 weeks	16.00 PC	4,164.14	66,626.24
30	NYK:70007A4710001 TRANSMITTER ASSEMBLY, PSO 4000 Lead time: 13 weeks	42.00 PC	2,727.03	114,535.26
<p>Anticipated Delivery: Schedule to be negotiated after receipt of purchase order. Please include the quotation reference on any purchase order(s) resulting from this quotation and address the purchase order to the following: William Waldrop - Sales Siemens Mobility, Inc., 2400 Nelson Miller Parkway Louisville, KY 40223 Email: jeff.waldrop@siemens.com Customer Service Email: ra.csorders.ic@siemens.com</p>				

Payment Terms:

**Expected Order Total: 396,493.76**

Tax (7.75%)	\$30,728.27
<b>Total</b>	<b>\$427,222.03</b>



**Metropolitan  
Transit  
System**

**DRAFT FOR EXECUTIVE COMMITTEE REVIEW DATE: 4/11/2024**

## **Agenda Item No. 6**

**MEETING OF THE SAN DIEGO METROPOLITAN TRANSIT SYSTEM  
BOARD OF DIRECTORS**

April 25, 2024

**SUBJECT:**

Light Rail Vehicle (LRV) Accident and Vandalism Repair Services – Contract Amendment

**AGENDA ITEM WILL  
BE PROVIDED  
BEFORE BOARD  
MEETING**

**1255 Imperial Avenue, Suite 1000, San Diego, CA 92101-7490 • (619) 231-1466 • [sdmts.com](http://sdmts.com)**

San Diego Metropolitan Transit System (MTS) is a California public agency comprised of San Diego Transit Corp., San Diego Trolley, Inc. and San Diego and Arizona Eastern Railway Company (nonprofit public benefit corporations). MTS member agencies include the cities of Chula Vista, Coronado, El Cajon, Imperial Beach, La Mesa, Lemon Grove, National City, Poway, San Diego, Santee, and the County of San Diego. MTS is also the For-Hire Vehicle administrator for nine cities.





**Metropolitan  
Transit  
System**

**DRAFT FOR EXECUTIVE COMMITTEE REVIEW DATE: 4/11/2024**

## **Agenda Item No. 7**

MEETING OF THE SAN DIEGO METROPOLITAN TRANSIT SYSTEM  
BOARD OF DIRECTORS

April 25, 2024

**SUBJECT:**

Increased Authorization for Legal Services Contract to Pay Projected Expenses in Fiscal Year 2025 – Contract Amendment

**RECOMMENDATION:**

That the San Diego Metropolitan Transit System (MTS) Board of Directors:

1. Ratify Amendment 9 to MTS Doc. No. G2202.0-19, with Meyers Nave, in the amount of \$150,000.00 as shown in Attachment A; and
2. Authorize the Chief Executive Officer (CEO) to execute Amendment 10 to MTS Doc. No. G2202.0-19, with Meyers, in the amount of \$600,000.00, in substantially the same format as Attachment B.

**Budget Impact**

The total cost of today's proposed action is estimated to be \$750,000.00, bringing the total funding of the Meyers contract to \$1,475,000.00. Legal costs are billed to the Legal Department, Human Resources Department, Risk Department, or Capital Projects budgets depending on the individual case or issue requiring legal services.

**DISCUSSION:**

On October 11, 2018 (Agenda Item No. 12), the Board approved a panel of qualified law firms to assist MTS, San Diego Trolley, Inc. (SDTI) and San Diego Transit Corporation (SDTC) with various legal matters on an as-needed basis. Thereafter, MTS began contracting with the approved firms for designated amounts.

Legal services needs are estimated every year during the MTS budget process. Each department or capital project that may incur legal fees evaluates ongoing matters and upcoming projects or cases and builds the estimated legal services costs into each department's budget. Most legal services costs are borne by the Risk Department (for tort liability and workers' compensation cases), the Human Resources Department (for labor and employment advice and litigation), and the Legal Department (for general advice and special projects). Storm water





compliance matters are billed to the Storm Water Department budget, and matters involving the Desert Line or legal issues related to property owned by the San Diego & Arizona Eastern Railroad entity (SD&AE) are billed to the SD&AE budget.

If the contract funding is below the estimated needs for the new fiscal year, then a contract amendment adding funding is processed according to Board Policy 41. The contract proposed for today's action requires Board authority under Board Policy 41.

The Meyers Nave law firm provides representation on different specialties of law, such as eminent domain, employment practices, real estate/land management, and environmental law.

Today's proposed contract increase is based upon Meyers Nave's current caseload, the likelihood that a particular case may go to trial, and anticipated future litigation assigned to Meyers Nave in the current fiscal year. If the anticipated need is not realized, then the excess funding authority will be carried over to the next fiscal year.

Today's proposed action would ratify Amendment 9, which was previously issued under the CEO's Policy 41 signature authority, and approve new Amendment 10, as described below.

Amendment 9 (Ratify):

Amendment 9 (Attachment A) was issued for an increase in funds by \$150,000.00.

Amendment 10 (Approve):

Amendment 10 (Attachment B) for an increase in funds by \$600,000.00

Therefore, Staff recommends that the MTS Board of Directors:

1. Ratify Amendment 9 to MTS Doc No. G2202.9-19, with Meyers , in the amount of \$150,000.00 as shown in attachment A; and
2. Authorize the Chief Executive Officer (CEO) to execute Amendment 10 to MTS Doc. No. G2202.10-19, with Meyers, in the amount of \$600,000.00, in substantially the same format as Attachment B.

/s/ Sharon Cooney  
Sharon Cooney  
Chief Executive Officer

Key Staff Contact: Julia Tuer, 619.557.4515, [Julia.Tuer@sdmts.com](mailto:Julia.Tuer@sdmts.com)

Attachment: A. Draft Amendment MTS Doc No. G2202.9-19  
B. Draft Amendment MTS Doc No. G2202.10-19



# Metropolitan Transit System

## Amendment 9

March 27, 2024

MTS Doc No. G2202.9-19

### LEGAL SERVICES

Meyers Nave  
Mr. David W. Skinner  
Partner  
101 W. Broadway, Suite 1105  
San Diego, CA, 92101

This shall serve as Amendment No.9 to the original agreement G2202.0-19 as further described below.

### SCOPE

There shall be no changes to the scope of work.

### SCHEDULE

There are no changes to the expiration of the overall agreement which remains December 31, 2026.

### PAYMENT

This contract amendment shall authorize costs not to exceed \$150,000.00. The total value of this contract including this amendment shall be in the amount of \$875,000.00. This amount shall not be exceeded without prior written approval from MTS.

Please sign and return the copy to the Contract Specialist at MTS. All other terms and conditions shall remain the same and in effect. Retain the other copies for your records.

Sincerely,

  
\_\_\_\_\_  
Sharon Cooney, Chief Executive Officer

Agreed:

  
\_\_\_\_\_  
David W. Skinner, Managing Partner  
Meyers Nave

Date: April 2, 2023





# Metropolitan Transit System

## Amendment 10

April 25, 2024

MTS Doc No. G2202.10-19

### LEGAL SERVICES

Meyers Nave  
Mr. David W. Skinner  
Partner  
101 W. Broadway, Suite 1105  
San Diego, CA, 92101

This shall serve as Amendment No.10 to the original agreement G2202.0-19 as further described below.

### SCOPE

There shall be no changes to the scope of work.

### SCHEDULE

There are no changes to the expiration of the overall agreement which remains December 31, 2026.

### PAYMENT

This contract amendment shall authorize costs not to exceed \$600,000.00. The total value of this contract, including this amendment, shall be in the amount of \$1,475,000.00. This amount shall not be exceeded without prior written approval from MTS.

Please sign and return the copy to the Contract Specialist at MTS. All other terms and conditions shall remain the same and in effect. Retain the other copies for your records.

Sincerely,

Agreed:

\_\_\_\_\_  
Sharon Cooney, Chief Executive Officer

\_\_\_\_\_  
David W. Skinner, Partner  
Meyers Nave

Date: \_\_\_\_\_





**Metropolitan  
Transit  
System**

**DRAFT FOR EXECUTIVE COMMITTEE REVIEW DATE: 4/11/2024**

## **Agenda Item No. 8**

MEETING OF THE SAN DIEGO METROPOLITAN TRANSIT SYSTEM  
BOARD OF DIRECTORS

April 25, 2024

**SUBJECT:**

Imperial Avenue Division (IAD) Overhead Charging System – Contract Award

**RECOMMENDATION:**

That the San Diego Metropolitan Transit System (MTS) Board of Directors authorize the Chief Executive Officer (CEO) to execute MTS Doc. No. B0761.0-24 (in substantially the same format as Attachment A), with Heliox Technology North America, LLC (Heliox), for the provision of the IAD overhead charging system, for a term of five (5) years, for a total of \$3,358,171.90.

Budget Impact

The total contract cost of these services is estimated to be \$3,358,171.90 (Attachment C). The purchase of the chargers and pantographs totaling \$2,631,665.00 will be funded by the Capital Improvement Project (CIP) under Work Breakdown Structure Element (WBSE) 3009122601 and the warranty/service level agreement totaling \$726,506.90 will be funded by the San Diego Transit Corporation (SDTC) Operating Budget General Cost Center 902014.

**DISCUSSION:**

In 2018, the California Air Resources Board (CARB) passed the Innovative Clean Transit (ICT) regulation, which mandated transit operators to transition to a fully zero emission bus fleet by 2040. In 2020, MTS created its Zero Emission Bus (ZEB) Transition Plan in accordance with the ICT regulation. Under MTS's ZEB Transition Plan, the agency will be procuring ZEBs and charging infrastructure to support this technology throughout the transition to a 100% ZEB fleet. Due to site constraints at each of MTS's bus yards, all future charging equipment is expected to be a depot overhead pantograph charging system to help minimize loss of space.

Today's proposed action is for the contractor to provide an overhead charging system (Phase I) at IAD, consisting of thirty (30) overhead depot pantographs and ten (10) depot chargers, 180 kWh power charging cabinets, related commissioning, and testing, as well as a 5-year warranty/service level agreement. This will provide capacity to charge thirty (30) buses at IAD. Each of the ten (10) chargers can charge up to three (3) buses – hence the need for thirty (30) pantographs. The current fleet at IAD includes on hundred forty-one (141) buses.



On May 13, 2021 (Agenda Item No. 9), the MTS Board approved the purchase of eight (8) Fast DC 180 kW Electric Chargers, and twenty-four (24) overhead inverted pantographs for the South Bay Maintenance Facility (SBMF) from Heliox. Heliox has the newest telematics system, simultaneous charging functionality (parallel charging), remote monitoring, and energy management. The chargers have a maximum charge rate of 180 kW. Rate of charger varies considerably based on bus battery management system profiles that include temperature balancing / monitoring to maintain the life expectancy of the high-voltage batteries. The chargers and pantographs for IAD under this procurement are the same as those at SBMF and have the same 3:1 sequential charging ratio.

MTS Policy No. 52, "Procurement of Goods and Services", requires a formal competitive process for procurements and service contracts over \$150,000.00. On August 26, 2023, MTS issued a Request for Proposals (RFP) for qualified proposers to provide overhead charging system. On October 13, 2023, MTS received two proposals from:

Proposer Name	Firm Disadvantaged Business Enterprise Certification
Heliox Technology North America, LLC	N/A
LL Real Estate Group DBA Real City Charging Solutions	Disabled Veteran Business Enterprise (DVBE), Person with Disabilities Business Enterprise (PDBE), Small Business (SB) (Micro)

On December 8, 2023, an evaluation committee consisting of representatives from Finance, MTS Bus and CIP met and scored the proposal based on the following evaluation criteria:

Evaluation Criteria	Total Possible Points
Qualifications of the Firm	25
Staffing, Organization, and Management Plan	25
Work Plan	25
Cost and Price	25
<b>Total</b>	<b>100</b>

The table below represents the proposer's initial score and ranking:

Proposer Name	Cost (Inclusive of tax)	Technical Score	Cost Score	Total Score (Maximum total score: 100)	Ranking
Heliox	\$3,886,665.00	53.00	25.00	78.00	1
Real City Charging Solutions	\$5,828,287.75	28.00	16.74	44.74	2

Based on this scoring and the initial review, the evaluation committee proceeded with Heliox as the more superior proposal. They requested for a revised proposal from Heliox including clarification questions.

On February 6, 2024, MTS interviewed Heliox on the entire proposal including the responses to the revised proposal. Shortly thereafter, MTS requested another revised proposal which Heliox submitted on February 21, 2024. The proposal was for \$3,358,171.90 (\$3,179,146.90 + CA

sales tax \$179,025.00), a savings to MTS of \$528,493.10 from the initial proposal, a price that staff deems to be fair and reasonable.

Therefore, staff recommends that the MTS Board of Directors authorize the CEO to execute MTS Doc. No. B0761.0-24 (in substantially the same format as Attachment A), with Heliox, for the provision of the IAD overhead charging system, for a term of five (5) years, for a total of \$3,358,171.90.

/s/ Sharon Cooney  
Sharon Cooney  
Chief Executive Officer

Key Staff Contact: Julia Tuer, 619.557.4515, [Julia.Tuer@sdmts.com](mailto:Julia.Tuer@sdmts.com)

Attachments: A. Draft Agreement, MTS Doc. No. B0761.0-24  
B. Scope of Work  
C. Cost Form



# Metropolitan Transit System

## STANDARD AGREEMENT FOR

MTS DOC. NO. B0761.0-24

### PROCUREMENT OF THIRTY (30) OVERHEAD DEPOT PANTOGRAPHS AND TEN (10) DC III FAST CHARGING POWER CABINETS, COMMISSIONING AND SERVICE LEVEL AGREEMENT FOR THE IAD DIVISION

THIS AGREEMENT is entered into this \_\_\_\_\_ day of \_\_\_\_\_, 2024 in the State of California by and between San Diego Metropolitan Transit System ("MTS"), a California public agency, and the following, hereinafter referred to as "Contractor":

Name: Heliox Technology North America, LLC Address: 165 Ottley Drive NE, Ste. 205  
Atlanta, GA 30324  
 Form of Business: LLC  
 (Corporation, Partnership, Sole Proprietor, etc.) Email: david.aspinwall@heliox-energy.com  
 Telephone: 404-397-3317

Authorized person to sign contracts David Aspinwall President Americas & Group  
 CCO  
 Name Title

The Contractor agrees to provide services as specified in the conformed Scope of Work/Technical Specification (Exhibit A), Contractor's Cost/Pricing Form (Exhibit B), and in accordance with the Standard Agreement, including Standard Conditions (Exhibit C), Federal Requirements (Exhibit D) and Forms (Exhibit E).

The contract term is for five (5) base years effective May 1, 2024 to April 30, 2029.

Payment terms shall be net 30 days from invoice date. The total cost of this contract shall not exceed \$3,358,171.90. This amount shall not be exceeded without the express written consent of MTS.

SAN DIEGO METROPOLITAN TRANSIT SYSTEM	HELIOX TECHNOLOGY NORTH AMERICA, LLC
By: <u>Sharon Cooney, Chief Executive Officer</u>	By _____
Approved as to form:	Title: _____
By: <u>Karen Landers, General Counsel</u>	



## **SCOPE OF WORK/TECHNICAL SPECIFICATIONS**

### **5.1. BACKGROUND**

San Diego Metropolitan Transit System (MTS) is looking for a Contractor to provide overhead charging system (Phase I) at MTS's Imperial Avenue Division (IAD) division. All goods delivery and services performed shall be completed 12 months after contract execution.

MTS currently has a Zero Emissions Bus (ZEB) program which will be procuring ZEBs and charging infrastructure to support this technology throughout the transition to 100% ZEB fleet. In addition, MTS has produced a Transition Study that outlines its commitment to transitioning its bus fleet from Compressed Natural Gas (CNG) to 100% ZEB through 2040. This was initiated by the passing of the California Air Resources Board (CARB) Innovative Clean Transit Rule (ICT), which is a purchase mandate of ZEBs for all California transit agencies. Due to site constraints at each of MTS's bus yards, all future charging equipment is expected to be a depot overhead pantograph charging system to help minimize loss of space. The overhead charging infrastructure is planned to be implemented at four (4) divisions supporting up to 600+ ZEBs over the next 20 years.

The criteria below describe the expected overhead charging system capabilities, and quantity for MTS's Battery Electric Bus (BEB) infrastructure at the IAD division, Phase I:

Note: the following counts are subject to change at the discretion of MTS.

MTS Division: IAD, 100 16<sup>th</sup> Street, San Diego, CA 92101:

- A. Ten (10) DC III Fast Charging Power Cabinets.
- B. Thirty (30) Overhead Depot Pantographs.

### **5.2. MTS OVERHEAD CHARGING SYSTEM CRITERIA**

At a minimum, the expected overhead charging system must be able to integrate with MTS's current Charge Management System (CMS) and existing electric bus specifications that are outlined below.

#### **Expected Charging System (quantities)**

- A. Thirty (30) Gantry Mounted Depot Chargers (Pantograph)
  - o Thirty (30) Radio Frequency Identification (RFID) Readers (recommend RFID tags for vehicles)
- B. Ten (10) DC III: minimum of 180 kW rate of charge power cabinets

#### **Existing Electric Bus Type/Systems**

- A. Seven (7) Gillig 40-foot battery electric bus (444 kWh energy storage system (ESS))
- B. Six (6) New Flyer XE40 40-foot (466 kWh ESS)
- C. Twelve (12) New Flyer XE60 60-foot (610 kWh ESS)

#### **Existing Charge Management System**

- A. BP Pulse



### 5.3. OVERHEAD CHARGING SYSTEM TECHNICAL SPECIFICATIONS

**A. Overhead Depot Charging Specification (Outdoor):** The outdoor overhead charging system must be capable to sequential, and simultaneous charge that's programmable with different strategies (e.g., charge each bus to max allowable capacity sequentially/simultaneously, with up to a design ratio (3:1) of three (3) depot pantographs connected to one (1) power cabinet. MTS, and/or charge management system should be able to adjust the programming to be able to adapt to MTS's service requirements, and allow flexibility in the technological design and programming of this system.

- i. **Depot Overhead Charging System**: shall consists of up to thirty (30) depot pantographs, and ten (10) power cabinets that are interoperable with all commercially available electric bus manufacturers including, but not limited to:
  - a) New Flyer Xcelsior XE40/60 (have been validated, and tested).
  - b) Gillig BEBs (have been validated, and tested).

Overhead charging system shall also include the following, but not limited to:

- a) Depot pantographs must meet the following height requirements
  - i. Mounting height no higher than 16'.3"
  - ii. Maintain a minimum clear height of 12'.15" while retracted
  - iii. Bus charging height: between 10.2 – 11.4

Dimensions/Weight minimum:

- i. Height (home position) 50"
- ii. Width 45"
- iii. Depth 45"
- iv. Weight 300lbs

- b) Power cabinets capable of continuous 180 kW rate of charge.

Dimensions/Weight minimum:

- i. Height 95"
- ii. Width 32"
- iii. Depth 32"
- iv. 1300 lbs

- c) RFID Readers for additional communication protocol authentication that is SAE J3105B revision compliant for multiple depot pantographs charging in close proximity. In addition, to assist in encoding and programming RFID tags for all buses to utilize overhead charging system with RFID readers.
- d) Uninterruptible Power Supply (UPS) system for depot pantographs in case of power failures/outages that requires pantographs to retract (or approved design equal). This system is required to help prevent damage/injury of assets and personnel in the event of a power outage during a charging session.
- e) Indicator light system (MTS design approval).

- f) A complete inventory asset list of all components included and required for proposed overhead charging system that is expected to be delivered to MTS's division.
- ii. **Simultaneous and Sequential Electric Charging Equipment**: that can provide up to three (3) BEBs to connect (pantographs) to one (1) power cabinet, that are capable to charge either simultaneously or sequentially. This provides the ability, and flexibility to manage multiple bus energy demand requirements to effectively energize buses and to deploy them into service on schedule.
- iii. **Underwriter Laboratories (UL) Certified for Outdoor and Safety Operation**: overhead charging system will be installed outdoor and exposed to San Diego's micro climates. The overhead charging equipment must be UL certified completely for outdoor use and certified for all safety operations for 24 hours a day, every day of the year including, , but not limited to:
- a) All potential weather events including rain, wind, and sun (heat/temperature)
  - b) Safety of personnel protection systems for electric vehicles
  - c) Safety of electric vehicle supply equipment
  - d) Electric vehicle conductive charging system
  - e) Minimum of ten (10) years.
- iv. **Compliant SAE J3105 Depot Overhead Charging System**: the overhead charging system must be compliant with SAE-approved charging standard SAE J3105 and continue to stay up-to-date with any J3105 revisions throughout the life of the Service Level Agreement at a minimum that's negotiated between MTS and Contractor. Proposers shall include a detailed description of charging infrastructure required to charge buses at depot and specify its compliance with SAE J3105. Infrastructure to be included, but not limited to:
- a) Compliant with J3105B – revision for overhead depot charging system with communication protocol for multiple pantographs in close proximity.
- v. **Bus Manufacturer BEB System(s), and Compatibility**: proposed overhead depot charging systems for use with BEBs and in conjunction with BEB's battery management system (BMS) must comply with the battery manufacturers electrical and thermal limits.
- a) Must be able to work/coordinate with bus manufacturers and component vendors for all back-end programming/firmware, and updates that include, but not limited to:
    - o BMS/battery system (have been tested/validated).
    - o Charge controller (have been tested/validated).
    - o Traction motor (have been tested/validated).

**B. Inspection, Acceptance and Commissioning:**

- i. The Contractor will coordinate with all necessary stakeholders involved, including but not limited to: MTS, designer, construction management, CMS Contractor (BP Pulse), utility [San Diego Gas & Electric (SDG&E)], bus manufacturer/component vendors, micro-grid contractor (if applicable) during installation, inspection, testing, acceptance, and commissioning of overhead charging system.
- ii. The Contractor shall provide an acceptance testing and commissioning plan for all supplied equipment for the overhead charging system that will include detailed checklist for testing, validating, and commissioning the overhead charging system. Included in testing/commissioning plan shall be a list of action items to be performed by installation contractor and/or third-party vendors during installation that would require technical support, and how the Contractor plans to provide support for these action items.
- iii. MTS will prepare a punch list in coordination with Contractor as a result of equipment physical inspections, start-up tests including but not limited to: bus, and CMS, and functional demonstrations. The completion schedule for punch list will be agreed upon by MTS and Contractor.
- iv. During time of acceptance, validation/testing, and commissioning, Contractor shall submit a written report to MTS listing all incidents, and action items required throughout the test/validation, and commissioning plan.
- v. Acceptance testing/validation, and commissioning involves ensuring that the overhead charging system solution integrates with up to fifteen (15) of MTS's existing and/or planned BEB fleet that will potentially utilize the overhead charging system. In addition, overhead system solution must be able to integrate with MTS's existing CMS Contractor, BP Pulse, and demonstrate the successful operation of CMS management, monitoring, troubleshooting, and data reporting. MTS may observe any testing in progress.
- vi. Overhead charging system acceptance will be considered complete upon the Contractor's demonstration to MTS that the overhead depot charging system's design, delivery, assembled, installation, and testing/commissioning are fully compliant with all operational requirements, and all punch list items are complete. The Contractor shall coordinate the scheduling of acceptance, testing/validation, and commissioning action items to minimize disruptions to MTS's bus operations.

**C. Performance Testing/Validation (including but not limited to):**

- i. Pantograph/Power Cabinets: The Contractor shall demonstrate/validate, and commission overhead charging system with up to fifteen (15) BEBs for all thirty (30) pantographs including RFID readers.
- ii. Emergency Shutdown Protocol: The operation of the emergency shutdown system shall be tested/validated for compliance.

**D. Functional Tests (including but not limited to):**

- i. Simultaneous and Sequential Charging: for all ten (10) power cabinets, and thirty (30) depot pantographs.

- ii. CMS Integration: for remote monitoring, troubleshooting, and management of overhead charging system.
- iii. Ancillary Components and Action Items: operation and function of ancillary components and action items of overhead charging system shall be tested. Incidents shall be recorded and corrected by Contractor to MTS's satisfaction. Ancillary components and action items include, but not limited to: indicator lighting, doors, and locks, control panels, RFID readers & tags, UPS (or design equal), switches, and any security systems.

Final commissioning and acceptance of the overhead charging system will be completed on up to fifteen (15) planned BEBs that will utilize the overhead system. The Contractor shall coordinate with BEB manufacturers to ensure each power cabinet, and pantograph integrates with potential BEBs to use system, and CMS, as applicable and to the requirement of this RFP, including:

- i. Punch list: resulting from inspection, testing/validation, and commissioning plan carried out by MTS and Contractor, are addressed and completed to the satisfaction of MTS.
- ii. Contractor has presented all required deliverables per the contract terms.
- iii. The Contractor has completed all operational and emergency response training.

#### **5.4. WARRANTY**

Contractor shall provide a minimum five (5) year parts and labor Service Level Agreement (SLA) that includes planned operations, and maintenance which shall commence upon the date of final acceptance of overhead charging system issued by MTS. Contractor should clearly define all terms of the warranty in their response. The Contractor proposer is invited to list other available warranty options, clearly defining terms. In addition, in the proposal as an add alternate, the Contractor to recommend potential spare parts and quantities MTS to keep on-hand initially after final commission of charging equipment.

- A. **Warranty Repairs:** A Contractor representative/field technician must respond on site or via remote diagnostic within 24 hours of receiving initial notification from MTS and/or CMS vendor under SLA.
- B. **Spare Parts Plan:** The Contractor shall provide MTS with a spare parts list that the contractor will maintain during the Service Level Agreement (SLA) negotiated, to meet the warranty repair requirements under the contract for the overhead charging system.

#### **5.5. TROUBLESHOOTING/MAINTENANCE SUPPORT**

Proactive remote diagnostics, troubleshooting, and fault reporting will be managed through 24/7 monitoring by CMS vendor. MTS requires Overhead Charger System manufacturer to allow CMS vendor full access through Open Charge Point Protocol (OCPP 1.6J ). In addition, Contractor shall provide communication protocol plan/system for repair, and tracking work orders, component replacement inventory, and warranties for MTS and/or CMS vendor to access.

Support procedures/SLA must meet existing charging equipment system warranties or better.

- i. **Response:** On site or via remote diagnostic within 24 hours of receiving notice from MTS and/or CMS Contractor.

- A. Respond and manage charging interruptions: Accommodate charging operations, repairs and communication protocols where bus charging sessions are interrupted due to either scheduled or unscheduled maintenance operations, mid-charging, and/or require charger system component repairs.
- B. Overhead charging system must remain functional during an internet or network outage (e.g. redundancy plan, failure modes, etc.).

## 5.6. TRAINING

Contractor shall provide training for MTS staff as a train-the-trainer type class setting upon completion of system installation, and commissioning. The training plan shall at a minimum include overhead charging system familiarization, preventative maintenance requirements, and observation, troubleshooting, and emergency response. The Contractor shall provide a training plan and schedule of hours that are required for MTS approval.

The Contractor shall also provide parts manuals, training procedures (operating/maintenance), and any guidance documents, in electronic (PDF) format. Maintenance manuals shall include step-by-step instructions to properly maintain all overhead charging system equipment/components. In addition, to Process and Instrumentation Drawings (P&ID's) and detailed descriptions of system function and operation, maintenance manuals shall minimally include information on proper troubleshooting procedures, system logic, preventative maintenance plan, and repair procedures for all major components, and systems.

## 5.7. GENERAL REQUIREMENTS

- A. The Contractor shall coordinate with, but not limited to: bus manufacturers, CMS vendor, designer, construction management, electrical contractor, and utility, if specified, to finalize overhead charging equipment requirements.
- B. The Contractor shall provide CMS vendor full access to manage, and monitor overhead charging system through an Open Charge Point Protocol (OCPP) compliant system of 1.6J or greater. The method of control, and access level should include, but not limited to: charging optimization, schedule management, fault codes, remote monitoring, troubleshooting (system reset(s)), and all data points collected from overhead charging system.
  - i. The Contractor shall also include all OCPP revisions for overhead charging system produced by SAE J3105 under the warranty period negotiated.
  - ii. The Contractor shall provide a detailed description of all data monitoring, fault notification/description, and control solutions for proposed overhead charging system.
  - iii. All overhead charger notifications shall include, but not limited to: charge session data (ex. charge stopped/faulted), fault code errors, etc., and shall be readily accessible to MTS, and CMS Contractor.
- C. The Contractor shall coordinate with bus manufacturer/component sub-contractors to maintain proper communication protocol with overhead charging system and buses that include but not limited to: firmware updates, and any back-end programming that is required for charge session operations.
- D. An emergency shutdown system (ESD) shall be provided that includes, but not limited to:
  - i. Shall stop all BEB charging when ESD is activated.
  - ii. The ESD system shall be normally closed and trip open, and shall be expandable so additional switches may be added.
  - iii. ESD button location shall be determined during pre-construction and approved by MTS.

- E. Controls shall include features to ensure user safety protocols, in compliance with all applicable OSHA, NFPA, NEC, and any other safety regulations.
- F. The Contractor shall propose the best method(s) for needed data connections with overhead charging system.
- G. The Contractor shall provide detailed description for all security protocols - levels of access, and back-end security firewall(s), etc. for MTS approval. Proposers must complete the Vendor Security Questionnaire attached as Attachment 2.
- H. The Contractor shall provide MTS with all updates to maintenance manuals, parts lists, and procedures for all systems, equipment, and/or components of overhead charging system as issued by the Contractor and/or suppliers to Contractor.
- I. Installation shall comply with NEC.
- J. The Contractor shall also include a spare part plan recommendation for MTS post-warranty to keep on-hand to manage during the life expectancy of overhead system and minimize down times.

## 5.8. **VENDOR INFORMATION SECURITY RESPONSIBILITIES**

MTS has established the following responsibilities to ensure the security of vendor operations in accordance with MTS policies, standards, and SOPs. The following procedures outline the expectations for Contractor and any subcontractors:

- A. **Contractor Lists**-Contractor and any subcontractors must provide an up-to-date list of all staff working on the contract. This list should be promptly updated and submitted to MTS whenever there are staff changes.
- B. **ID and Security Clearances**-Contractor and subcontractor onsite technicians must be issued MTS security badges/key cards. These badges/key cards should be visibly displayed at all times while on MTS premises.
- C. **Incident Reporting**-Contractor and subcontractors agree to promptly report any security incidents or breaches involving their systems or access to the MTS Radio network and systems. Detailed incident response procedures should be provided, and cooperation in investigations, including the provision of necessary logs and evidence, is expected.
- D. **Change Management**-Contractor and subcontracted personnel must adhere to all applicable MTS change control processes and procedures.
- E. **Patch Management**-Contractor and subcontractors agree to promptly apply security patches and updates to their systems and software used to perform services in this contract.
- F. **Data Protection and Privacy**-The vendor must protect MTS data in accordance with applicable laws and regulations, including those related to data privacy. Appropriate safeguards should be implemented to ensure the confidentiality, integrity, and availability of MTS data.
- G. **Remote Access and Forms**-Remote access must be uniquely identifiable, and password management should comply with MTS password standards' reserves the right to determine the applicable virtual private network and encryption technologies used to access their systems and network. Remote access forms must be updated and submitted yearly or upon request by MTS.
- H. **Contractor Termination-Upon** departure of a contractor from MTS for any reason, Contractor or subcontractors must ensure that all sensitive information is collected and returned to MTS or destroyed within the timeframe specified in the original contract terms.
- I. **Keycard and Security Access**-Upon termination of the contract or at the request of MTS, Contractor and subcontractors must surrender all MTS-issued identification badges, access cards, equipment, and supplies immediately. Equipment and supplies retained by Contractor or subcontractors must be documented and authorized by the MTS contract POC or their designee.

- J. **Auditing and Compliance-** Contractor or subcontractor are required to comply with all applicable MTS security Policies , Standards and SOP's. Contractor and subcontractor must comply with MTS when conducting an audit or risk assessment based on contractual obligations and applicable security policy's, standard and SOP's set by MTS.
- K. **Disclosure and Sub-Contractor Security-**If the vendor engages subcontractors or third-party service providers, they must ensure that these entities adhere to the same vendor information security obligations outlined in this contract. The vendor is responsible for the security practices of their subcontractors and should perform due diligence in selecting and monitoring them.
- L. **Training and Awareness-**Contractor and subcontractors agree to provide security awareness training to individuals who have access to the MTS network or systems. The training should cover topics such as security policies, data handling, and incident response procedures. If training cannot be provided by Contractor or subcontracted staff then MTS provided training must be completed on initial access and yearly refresher training.

## 5.9. BUY AMERICA

This scope of work may trigger Buy America and/or Build America Buy America requirements, which apply to construction materials, manufactured products, rolling stock, iron and steel. The below list of definitions and examples is not exhaustive and is only to be used as illustrative and a guidance tool for Contractor compliance.

### A. [NOT APPLICABLE] CONSTRUCTION MATERIALS

### B. MANUFACTURED PRODUCT

Per IJJA Section 70912 (2)(B), all manufactured products used in the project must be produced in the United States. Examples for manufactured products provided per Appendix A to 49 CFR 661.3 include: Infrastructure projects not made primarily of steel or iron, including structures (terminals, depots, garages, and bus shelters), ties and ballast; contact rail not made primarily of steel or iron; fare collection systems; computers; information systems; security systems; data processing systems; and mobile lifts, hoists, and elevators.

### C. [NOT APPLICABLE] ROLLING STOCK

### D. IRON OR STEEL

Per IJJA Section 70912 (2)(A), all iron and steel used in the project must be produced in the United States. This means all manufacturing processes, from the initial melting stage through the application of coatings, occurred in the United States. Examples of iron and steel provided per Appendix A to 49 CFR 661.3 include: Items made primarily of steel or iron such as structures, bridges, and track work, including running rail, contact rail, and turnouts.

## 5.10. INVOICES

Invoices must be sent to the MTS Accounting Department, via email, at ap@sdmts.com. All invoices must have the Purchase Order and contract number clearly displayed to ensure timely payment. MTS will not pay on packing slips, receiving documents, delivery documents, or other similar documents. Invoices must be submitted for payment.

Payment terms shall be net 30 days from invoice date.

Contractors must also indicate if any of the invoiced amount(s) is for service or work provided by a subcontractor and indicate the amount that will be paid to the subcontractor. Contractors must also comply with the prompt payment requirements in the *Prompt Progress Payments* section of the Standard Conditions.

**5.11. [NOT APPLICABLE] MATERIAL SAFETY DATA SHEETS (MSDS)**

**5.12. [NOT APPLICABLE] NO RIGHT TO POST SIGNS**



Heliox					
Qty	Item Description	Heliox Internal Naming	Unit cost	Extended cost	Payment terms
10	180 kWh Power Cabinet	<i>Depot Chargers: FAST DC/OC 180kW/60kW/60kW UL - Multi Port HE9821001-01</i>	\$ 79,500.00	\$ 795,000.00	Shipment is FOB destination. Paid 80% payment at shipment receipt and acceptance by MTS. Acceptance will be within 48 hours of receipt; 20% at commissioning acceptance. Payable within 30 days after the date of invoice.
4	Factory Acceptance Test	<i>Factory Acceptance Test Included FAT All Chargers</i>	\$ -	\$ -	N/A
30	Depot Pantograph	<i>Dispensers: DEPOT Inverted Pantograph (250A UL) - HE2121247-01 - Schunk SLS301.102 HE2121247-01. *Including: Control box + RFID + Status Light + Depot ACD with 12 second cycle time and maximum of 360mm of travel</i>	\$ 50,500.00	\$ 1,515,000.00	Shipment is FOB destination. Paid 80% payment at shipment receipt and acceptance by MTS. Acceptance will be within 48 hours of receipt; 20% at commissioning acceptance. Payable within 30 days after the date of invoice.
30	Bus Pairing/Commissioning	<i>Support: Bus Pairing / Commissioning. Includes support for integration with BP Pulse (In Hours)</i>	\$ 500.00	\$ 15,000.00	Invoiced after services are incurred. Payable within 30 days after the date of invoice.
30	Site Acceptance Test/Commissioning	<i>Support: Site Acceptance Test - SAT &amp; Commissioning 30 Depot Chargers *Including: Functional test</i>	\$ 3,000.00	\$ 90,000.00	Invoiced after services are incurred. Payable within 30 days after the date of invoice.
1	*Warranty/Service Level Agreement	<i>Support: 5 Year Warranty / Service Level Agreement</i>	\$ 726,506.90	\$ 726,506.90	Each year billed at the beginning of the year. Payable within 30 days after the date of invoice.
1	Delivery/Transportation/Freight Cost	<i>Support: Transportation. Shipping and Handling To San Diego, CA</i>	\$ 15,000.00	\$ 15,000.00	Invoiced after services are incurred. Payable within 30 days after the date of invoice.
1	Lift Rental For Overhead Commissioning	<i>Support: Lift Rental For Overhead Commissioning</i>	\$ 20,000.00	\$ 20,000.00	Invoiced after services are incurred. Payable within 30 days after the date of invoice.
2	Site Assessment	<i>Support: Site Assessment (days)</i>	\$ 1,320.00	\$ 2,640.00	Invoiced after services are incurred. Payable within 30 days after the date of invoice.
1	Heliox Recommended Training	<i>Support: Training - Maintenance &amp; Operation - 2 Days, Max 12 Persons Per Class</i>	\$ -	\$ -	N/A
<b>Total Proposal Cost</b>				<b>\$ 3,179,146.90</b>	
CA Sales Tax				<b>\$ 179,025.00</b>	Paid as part of each good received
<b>Overall Including Tax</b>				<b>\$ 3,358,171.90</b>	

\*Warranty Payment

Year 1	\$	119,000.00
Year 2	\$	130,900.00
Year 3	\$	143,990.00
Year 4	\$	158,389.00
Year 5	\$	174,227.90
Total	\$	726,506.90



**Metropolitan  
Transit  
System**

**DRAFT FOR EXECUTIVE COMMITTEE REVIEW DATE: 4/11/2024**

**Agenda Item No. 9**

MEETING OF THE SAN DIEGO METROPOLITAN TRANSIT SYSTEM  
BOARD OF DIRECTORS

April 25, 2024

**SUBJECT:**

Railroad Ties – Contract Award

**RECOMMENDATION:**

That the San Diego Metropolitan Transit System (MTS) Board of Directors authorize the Chief Executive Officer (CEO) to execute MTS Doc. No. L1663.0-24 (in substantially the same format as Attachment A), with Balfour Beatty Infrastructure, Inc. (Balfour), in the amount of \$167,475.00 for the purchase of railroad ties.

Budget Impact

The total contract cost of materials is estimated to be \$167,475.00 (Attachment C). The project will be funded by the San Diego Trolley, Inc. (SDTI) Track Maintenance Operating Budget account 370016-545500.

**DISCUSSION:**

Railroad ties within the SDTI right-of-way are essential to the operation of the Trolley. The typical useful life of railroad ties is approximately twenty-five (25) years, and MTS currently has ties on the system that have reached this term. Changing out ties that have reached and outlived their useful life is essential to having Trolley tracks in a State of Good Repair (SGR).

On January 20, 2024, MTS issued an Invitation for Bid (IFB) for the purchase of railroad ties. A total of four (4) bids were received by the deadline of February 21, 2024, and are summarized as follows:

Company Name	Bid Amount **	Firm Certification
Gemini Forest Products *	\$136,710.00	N/A
B&B Diversified Materials *	\$141,400.00	Disadvantage Business Enterprise (DBE)
Balfour	\$154,000.00	N/A
Trans Canada Forests Products	\$172,648.00	N/A

\*Non-responsive bidder

\*\*Does not include taxes



Gemini Forest Products' bid was rejected and deemed non-responsive as they did not submit the bid form as required in the IFB.

B&B Diversified Materials' bid was rejected and deemed non-responsive as they could not confirm that the ties would meet and comply with the Scope of Work/Minimum Technical Specifications per the IFB.

Based on the bids received, and in comparison, with the MTS Independent Cost Estimate (ICE) of \$180,873.00, staff determined the Balfour's bid price to be fair and reasonable.

Therefore, staff recommends that the MTS Board of Directors authorize the CEO to execute MTS Doc No. L1663.0-24 (in substantially the same format as Attachment A), with Balfour, in the amount of \$167,475.00 for the purchase of railroad ties.

/s/ Sharon Cooney  
Sharon Cooney  
Chief Executive Officer

Key Staff Contact: Julia Tuer, 619.557.4515, [Julia.Tuer@sdmts.com](mailto:Julia.Tuer@sdmts.com)

Attachments: A. Draft Agreement, MTS Doc. No. L1663.0-24  
B. Scope of Work  
C. Bid Form



STANDARD AGREEMENT FOR MTS DOC. NO. L1663.0-24 RAILROAD TIES

THIS AGREEMENT is entered into this \_\_\_\_\_ day of \_\_\_\_\_, 2024 in the State of California by and between San Diego Metropolitan Transit System ("MTS"), a California public agency, and the following, hereinafter referred to as "Contractor":

Name: Balfour Beatty Infrastructure, Inc. Address: 300 Galleria Parkway, Suite 2050 Atlanta GA 30339 City State Zip Form of Business: Corporation (Corporation, Partnership, Sole Proprietor, etc.) Email: wpfeffer@balfourbeattyus.com Telephone: 909-770-7020

Authorized person to sign contracts Will Pfeiffer Area Operations Manager - Rail Name Title

The Contractor agrees to provide goods as specified in the conformed Scope of Work/Minimum Technical Specification (Exhibit A), Contractor's Bid/Pricing Form (Exhibit B), and in accordance with the Standard Agreement, including Standard Conditions (Exhibit C), Federal Requirements (Exhibit D), and Forms (Exhibit E).

The contract term is effective from May 1, 2024 through August 1, 2024.

Payment terms shall be net 30 days from invoice date. The total cost of this contract shall not exceed \$167,475.00 without the express written consent of MTS.

Table with 2 columns: SAN DIEGO METROPOLITAN TRANSIT SYSTEM and BALFOUR BEATTY INFRASTRUCTURE INC. containing signature lines for Sharon Cooney and Karen Landers on the MTS side, and signature lines for the Contractor on the Balfour Beatty side.



# SCOPE OF WORK/TECHNICAL SPECIFICATIONS

---

## 1. GENERAL

Contractor shall provide Douglas Fir Railroad Ties (or hardwood as alternate material) as a one-time purchase. The estimated quantities are shown in Exhibit B. MTS may elect to reduce or increase the quantities to be purchased based on its needs and available budget, and that the estimated quantities provided are used for bidding purposes only.

Included in Section 3.26 of the General Provisions is the Request for Approved equal (RFA) information. Complete documentation should be provided in support of any RFAs submitted by Bidders for MTS' review and response, and must be submitted by the deadline provided in the calendar of events. Any RFAs submitted with the bid package at bid opening will not be accepted.

## 2. MATERIAL

- A. All timber cross ties and switch rail ties shall be new and conform to the current edition of the American Railway Engineering and Maintenance-of-Way Association (AREMA) Manual, Volume 1, Chapter 30 "TIES", except as modified herein.
- B. Industrial Grade Cross ties are not permitted.
- C. West Coast Species shall meet or exceed W.C.L.B Specifications –Standard No.17 Grading Rules; Section 6: Special Use Grades-Railroad Ties; Item 192-a "SELECT" Railroad Ties. They are square edged. Pieces shall have not less than 6 annual rings per inch, on any radius from the pith, over the top ¼ of the tie.
- D. Ties shall be produced from Douglas Fir listed in the AREMA Manual, Volume 1, Chapter 30, Part 3, Section 3.1 "TIMBER CROSS TIES".
- E. Western Species – Costal Douglas Firs (Cottonwood, Willow, Hackberry, Hem-Fir, Ponderosa Pine, Lodge Pine, Larch and Poplar) will not be acceptable.
- F. All cross ties shall be Douglas Fir AREMA grade five (5), or approved equal, and shall come with end plates.

## 3. QUALITY AND FABRICATION

- A. Ties shall be free from defects that may impair their strength or durability such as decay, splits, shakes, holes, checks, slanting grain, and large or numerous holes or knots.
- B. Ties shall be straight, well sawed, square cut at the ends, have bottom and top parallel, and have bark entirely removed.
- C. The AREMA Manual Part 3, Section 3.1.1.4 "Inspection" shall govern defect type, size, and location for determining acceptability of material.
- D. Kerf marks shall be 1/8' located on the top "sap side" of the cross tie.
- E. Kerf mark location as measured from end of tie shall be as follows:

Cross Tie Length

8 Feet

Distance for Cross Tie End

16 Inches

**4. DESIGN**

- A. Standard cross ties shall be eight (8) feet six (6) inches in length. Standard cross ties and contact rail ties shall measure seven (7) inches deep by nine (9) inches wide in cross section.
- B. Thickness, width, and length specified are minimum dimensions for green ties. Dry or treated ties may be one quarter (1/4) inches thinner or narrower than the specified sizes. Ties exceeding these dimensions by more than one inch shall be rejected.

**5. MACHINING, INCISING, AND ANTI-SPLITTING DEVICES**

- A. All ties shall be incised and have anti-splitting devices applied prior to seasoning. Incising shall be performed in accordance with AREMA Manual Section 3.6.2 "Preparation of Material Prior to Treatment (1995)".
- B. Dowels or nail plates only shall be used. Strip irons shall not be acceptable. Nail plates shall measure six (6) inches by eight (8) inches. Dowels shall be steel; either three (3) or four (4) fluted and shall be one half (1/2) inch in diameter with three-eighths (3/8)-inch root diameter. Dowels shall be eight and three-quarters (8 ¾) inches long.
- C. Dowels or nail plates shall be applied to each of each tie in accordance with AREMA Manual Section 3.1.6 "SPECIFICATIONS FOR DEVICES TO CONTROL THE SPLITTING OF WOOD TIES", and Section 3.1.7 "APPLICATION OF ANTISPLITTING DEVICES".
- D. Machining for all ties shall be performed in accordance with AREMA Manual Section 3.1.4 "SPECIFICATIONS FOR MACHINING CROSS TIES (2014)".

**6. CONDITIONING AND SEASONING**

- A. Ties shall be conditioned prior to preservative treatment. Conditioning shall be either by air drying, Boulton Drying, or vapor drying.
- B. The conditioning process shall conform to the AREMA Manual, Part 3, Section 3.6.3 "CONDITIONING PRIOR TO TREATMENT (2002)". The process shall reduce the moisture content of Douglas Fir to a level of fifty (50) percent or less.

**7. TREATMENT**

- A. Ties shall be treated with a creosote-coal tar solution (Grade C composition minimum) in conformance with the AREMA Manual Part 3, Section 3.7.2. "TREATMENT (2002)," or approved equal.
- B. Treatment shall be by the full-cell process to obtain the maximum net retention. Retention shall be eight (8) lbs./cubic ft min. or refusal.

**8. MARKING, BUNDLING, AND DELIVERY**

- A. Ties shall be marked prior to preservative treatment. Ties shall be branded in the middle top surface with symbols that indicate the year of manufacture and the identity of the plant.
- B. Ties shall be bundled with steel strapping twenty (20) to the bundle and shipped in groups according to type, size and length. Timbers cross ties and switch ties shall be carefully handled to avoid damage in accordance with AREMA MRE, Chapter 30. Tie deliveries shall be made by flatbed truck.
- C. The delivery locations shall be at San Diego Trolley 1341 Commercial Street San Diego CA 92113. The Contractor shall notify the MTS Project Manager five (5) calendar day prior to delivery of crossing ties.
- D. All orders must be delivered in a timely manner. MTS has determined that 90 calendar days or less from the date of Notice to Proceed (NTP) is a satisfactory time for delivery. All orders must be delivered complete within this time frame unless otherwise approved by MTS.

**9. INSPECTION AND CERTIFICATION**

- A. The Engineer may inspect ties at any time before, during, or after treatment for conformance to the Specifications. Green wood inspection prior to treating and end plating is preferred. Additional inspection after delivery may be made to ensure ties conform to the Specifications.
- B. The Manufacturer shall furnish, for each load of ties, a notarized certificate of compliance stating that the ties meet the requirements of these specifications.

**10. MEASUREMENT AND INVOICE PAYMENT**

- A. Measurement of acceptable materials shall be the actual number of each timber tie manufactured and delivered in accordance with the specifications.
- B. Payment shall be made for each timber tie delivered and accepted in accordance with the specifications, in the amount bid for each type furnished.
- C. Material not meeting the requirements of the specifications will be rejected. Rejected material shall be returned to the vendor at his expense.
- D. MTS shall process the invoice for payment within thirty (30) days of the final invoice approval date. Contractor shall reference the MTS purchase order number on the invoice, attach an itemized invoice along with supporting delivery receipts to the following address, and email to [AP@sdmts.com](mailto:AP@sdmts.com).
- E. MTS will not pay on packing slips, receiving documents, delivery documents, or other similar documents. Invoices must be submitted for payment. Contractors must also indicate if any of the invoiced amount is for work provided by a subcontractor and indicate the amount that will be paid to the subcontractor. Contractors must also comply with the prompt payment requirements in the Prompt Progress Payments of the Standard Conditions.

**11. PAYMENT TERMS**

Unless otherwise stated in the specifications or bid forms, one hundred (100%) of the contract price for each unit or units of material or equipment furnished and delivered under these specifications, will be paid to the Contractor within thirty (30) days after delivery to and acceptance by MTS of the unit or units ordered, as herein provided, and after the statements covering the unit or units have been presented to MTS by the Contractor.

Cash discounts as shown on the bid form shall be accepted at the option of MTS. Otherwise the terms will be Net thirty (30) from acceptance. Payment terms less than ten (10) days from acceptance will not be considered. **Advanced Payment is Not Allowable.**

**12. BUY AMERICA**

This scope of work may trigger Buy America and/or Build America Buy America requirements, which apply to construction materials, manufactured products, rolling stock, iron and steel. The below list of definitions and examples is not exhaustive and is only to be used as illustrative and a guidance tool for Contractor compliance.

**12.1. [NOT APPLICABLE] CONSTRUCTION MATERIALS**

**12.2. MANUFACTURED PRODUCT**

Per IJJA Section 70912 (2)(B), all manufactured products used in the project must be produced in the United States. Examples for manufactured products provided per Appendix A to 49 CFR 661.3 include: Infrastructure projects not made primarily of steel or iron, including structures (terminals, depots, garages, and bus shelters), ties and ballast; contact rail not made primarily of steel or iron; fare collection systems; computers; information systems; security systems; data processing systems; and mobile lifts, hoists, and elevators.

**12.3. [NOT APPLICABLE] ROLLING STOCK**

**12.4. IRON OR STEEL**

Per IJJA Section 70912 (2)(A), all iron and steel used in the project must be produced in the United States. This means all manufacturing processes, from the initial melting stage through the application of coatings, occurred in the United States. Examples of iron and steel provided per Appendix A to 49 CFR 661.3 include: Items made primarily of steel or iron such as structures, bridges, and track work, including running rail, contact rail, and turnouts.

**13. INVOICES**

Invoices must be sent to the MTS Accounting Department, via email, at [ap@sdmts.com](mailto:ap@sdmts.com). All invoices must have the Purchase Order and contract number clearly displayed to ensure timely payment. MTS will not pay on packing slips, receiving documents, delivery documents, or other similar documents. Invoices must be submitted for payment.

Payment terms shall be net 30 days from invoice date.



Contractors must also indicate if any of the invoiced amount(s) is for service or work provided by a subcontractor and indicate the amount that will be paid to the subcontractor. Contractors must also comply with the prompt payment requirements in the *Prompt Progress Payments* section of the Standard Conditions.

#### **4.14. MATERIAL SAFETY DATA SHEETS (MSDS)**

MTS retains the safety data sheets on an electronic database (currently CloudSDS). Upon award, Contractors shall email the MSDS for chemicals that any individuals may be exposed to, attention Ngan Nguyen, MTS Environmental Health and Safety Specialist at [Ngan.Nguyen@sdmts.com](mailto:Ngan.Nguyen@sdmts.com) to upload into the database. The Contractor shall notify the MTS Environmental Health and Safety Specialist if there are changes or updates to the MSDS during the term of the contract to ensure the MTS database is kept updated throughout the contract

#### **15. WARRANTY**

Bidders shall outline in detail their warranty on the equipment offered, including the method of adjustment in cases of equipment, component or parts failure. Warranty shall also be stated for installation labor, materials, and method of adjustment.

#### **16. REPLACEMENT PARTS**

Replacement parts and technical support for the specified equipment must be guaranteed by the manufacturer; to be available for a ten (10) year period from the date of purchase. Manufacturer shall keep parts books and maintenance manuals up-to-date for that period.

#### **17. DELIVERY AND ACCEPTANCE**

Equipment or any deliverable provided under this contract shall be delivered F.O.B. to SDTI, 1341 Commercial Street, San Diego, California 92113 unless otherwise specified, in first class condition, complete and ready for operation, and the Contractor shall assume all responsibility and risk of loss incident to said delivery.

Contractor shall indicate delivery date on the Bid Form unless already specified, in which case, shall be made within the time set forth. Delivery is part of the consideration and must be adhered to as specified.

Contractor will not be held liable for failure to make delivery because of strikes, construction of property, governmental regulations, acts of God or any other causes beyond his control, provided a written extension of time is obtained from MTS.

Upon delivery, MTS will acknowledge receipt of said items or products. Delivery shall not constitute acceptance. Upon inspection and testing (if necessary) by MTS, a determination will be made whether said items or products are in conformance with contract requirements. If found in conformance, MTS shall approve the Contractor's invoice for payment; thereby constituting acceptance. Payment terms begin from this point. If the delivered items or products are found not in compliance, MTS will immediately notify the Contractor, and furnish all details of deficiencies. Contractor shall correct the deficiencies or supply new items or products (at the discretion of MTS), and resubmit for inspection and testing (if necessary).

#### **18. [NOT APPLICABLE] LIQUIDATED DAMAGES**

#### **19. [NOT APPLICABLE] ACQUISITION OF ROLLING STOCK**

**L1663.0-24**  
**Railroad Ties IFB**  
**ATT 1 - Bid Form Rev2**

**\*\* Fill in the Green Cells \*\***

All order must be delivered in a timely manner. MTS has determined that 90 calendar days or less from the date of Notice to Proceed (NTP) and/or Purchase Order (PO) is a satisfactory time for delivery. All orders must be delivered complete within this time frame unless otherwise approved by MTS.

**Bidder to check one:**

Yes, I can meet the 90 calendar days or less delivery date from date of NTP

No, I cannot meet the 90 calendar days or less delivery date from date of NTP

If no, in how many calendar days can you delivery to MTS?

#	Description	*Est. # of Ties	**Unit Cost	**Extended Total
1	Standard cross ties shall be eight (8) feet six (6) inches in length. Standard cross ties and contact rail ties shall measure seven (7) inches deep by nine (9) inches wide in cross section	1,400	\$ 110.00	\$ 154,000.00
2	Total Delivery Cost (If applicable)			
3	<b>Overall Total (Basis for Award to Determine Lowest Bidder)</b>			<b>\$ 154,000.00</b>

\*These estimates are for bidding purposes only, and do not reflect actual amounts or quantities to be used or ordered by MTS. The estimated quantities do not commit MTS to authorize any purchase. Actual usage may be more or less than estimated.

\*\*This cost excludes any taxes. Bidders should not include any tax as part of the bid cost. MTS will calculate CA sales tax and any lumbar taxes at PO issuance.

Tax (7.75%)	\$11,935.00
CA Lumbar Tax (1%)	\$1,540.00
<b>Overall Total</b>	<b>\$167,475.00</b>
<b>(Basis for Award)</b>	



# Metropolitan Transit System

**DRAFT FOR EXECUTIVE COMMITTEE REVIEW DATE: 4/11/2024**

## **Agenda Item No. 10**

MEETING OF THE SAN DIEGO METROPOLITAN TRANSIT SYSTEM  
BOARD OF DIRECTORS

April 25, 2024

**SUBJECT:**

Hewlett Packard Enterprise (HPE) Synergy for Operations Control Center (OCC) Data Center – Contract Award

**RECOMMENDATION:**

That the San Diego Metropolitan Transit System (MTS) Board of Directors authorize the Chief Executive Officer (CEO) to execute MTS Doc. No. G2833.0-24 (in substantially the same format as Attachment A), with Nth Generation Computing, Inc. (Nth), effective for five (5) years, for the purchase of HPE Synergy equipment, software, and support/services in the amount of \$283,820.08.

Budget Impact

The total cost of this project is estimated to be \$270,634.00 plus \$13,186.08 sales tax, for a total of \$283,820.08 (Attachment C). The project will be funded by the Capital Improvement Program (CIP) – Server Refresh account and Information Technology (IT) Operations Budget cost center accounts reflected below.

<b>CIP WBSE/ Cost Center – GL Account</b>	<b>Amount</b>
1007122201-599902	\$183,329.08
661010-571250	\$100,491.00
<b>Total</b>	<b>\$283,820.08</b>

**DISCUSSION:**

The Operations Control Center (OCC) is the central location from which rail and security dispatch operates. The OCC includes technology to monitor the locations of trolley vehicles and to view CCTV camera footage at various locations. The back end of this facility requires network infrastructure to support this technology.

The servers hosting the virtual environment in the OCC data center, running critical applications for MTS, are nearing the end of service life and are due for replacement. These servers are running inside a HPE C7000 chassis purchased in 2013 and its replacement is now called the HPE Synergy chassis. This chassis is able to cover the same workload as the previous chassis



with less hardware which means lower licensing costs since there will be fewer virtual host servers to support.

On February 1, 2024, MTS issued an Invitation for Bid (IFB) requesting bids for HPE Synergy for OCC. By the bid due date of March 1, 2024, MTS received a total of eight (8) bids. The apparent lowest bidder, Saitech, was deemed non-responsive due to an invalidated bid. Therefore, staff proceeded with the second lowest responsive and responsible bidder, Nth.

Based on the cost comparison of the bids received, staff has determined Nth's pricing to be fair and reasonable and recommends awarding the contract to Nth.

#	Bidder	Disadvantaged Business Enterprise (DBE), Minority Business Enterprise (MBE), Small Business (SB), Woman-Owned Business (WBE)	Bid Amount (excluding 7.75% sales tax)
1	Saitech*	MBE	\$ 189,769.80
<b>2</b>	<b>Nth Generation Computing Inc</b>	<b>N/A</b>	<b>\$ 270,634.00</b>
3	Alztel	N/A	\$301,635.39
4	Questivity, Inc	SB, DBE	\$320,838.88
5	Southern Computer Warehouse, Inc	N/A	\$ 323,591.99
6	SHI International Corp	MBE, WBE	\$ 339,757.71
7	vPrime Tech Inc	MBE	\$ 480,095.99
8	Smart IT Pros Inc	MBE and WBE	\$ 519,425.31

\*Non-responsive Bidder

Therefore, staff recommends that the MTS Board of Directors authorize the CEO to execute MTS Doc. No. G2833.0-24 (in substantially the same format as Attachment A), with Nth, effective for five (5) years, for the purchase of HPE Synergy equipment, software, and support/services, in the amount of \$283,820.08.

/s/ Sharon Cooney  
 Sharon Cooney  
 Chief Executive Officer

Key Staff Contact: Julia Tuer, 619.557.4515, [Julia.Tuer@sdmts.com](mailto:Julia.Tuer@sdmts.com)

Attachments: A. Draft Agreement, MTS Doc. No. G2833.0-24  
 B. Scope of Work  
 C. Bid Form G2833.0-24



# Metropolitan Transit System

## STANDARD AGREEMENT FOR

MTS DOC. NO. G2833.0-24

### HEWLETT PACKARD ENTERPRISE (HPE) SYNERGY FOR OCC

THIS AGREEMENT is entered into this \_\_\_\_\_ day of \_\_\_\_\_, 2024 in the State of California by and between San Diego Metropolitan Transit System (“MTS”), a California public agency, and the following, hereinafter referred to as "Contractor":

Name: Nth Generation Computing, Inc. Address: 17055 Camino San Bernardo  
San Diego, CA 92127

Form of Business: Corporation  
(Corporation, Partnership, Sole Proprietor, etc.) Email: [bbryant@datelsys.com](mailto:bbryant@datelsys.com)

Telephone: (858) 451-2383

Authorized person to sign contracts	<u>Joyce Russell</u>	<u>EVP/CFO</u>
	Name	Title

The Contractor agrees to provide services with goods as specified in the conformed Scope of Work/Minimum Technical Specification (Exhibit A), Contractor’s Bid/Pricing Forms (Exhibit B), and in accordance with the Standard Agreement, including Standard Conditions (Exhibit C), and Forms (Exhibit D).

The contract term is for five (5) years effective May 10, 2024 through May 9, 2028.

Payment terms shall be net thirty (30) days from invoice date. The total cost of this contract (inclusive of CA 7.75% sales tax) shall not exceed \$270,634.00 without the express written consent of MTS.

SAN DIEGO METROPOLITAN TRANSIT SYSTEM	NTH GENERATION COMPUTING, INC
By: <u>Sharon Cooney, Chief Executive Officer</u>	By _____
Approved as to form:	
By: <u>Karen Landers, General Counsel</u>	Title: _____



## 4. SCOPE OF WORK/TECHNICAL SPECIFICATIONS

---

### 4.1. INTRODUCTION

MTS's Information Technology (IT) Department is soliciting bids from experienced firms' resellers and/or individuals capable of providing a server refresh for Operations Control Center (OCC) VMware cluster and replacement of Hewlett Packard Enterprise (HPE) C7000 chassis. The hardware is to replace the HPE C7000 chassis at OCC which was purchased in 2013. C7000 and blade servers are nearing end of service life. Servers need to be CTO from HPE. The OCC VMware cluster is currently running on 9 server blades within an HPE C7000 chassis. The HPE Synergy is the replacement for the older C7000 chassis. We are consolidating down to 6 server blades with similar or better resources to support the same workloads. This means less hardware and power required to support the same environment and lower licensing costs since less ESXi hosts to license, 6 instead of 9. MTS seeks a one-time purchase of the equipment listed in Attachment 1, plus five years of customer support service.

### 4.2. MINIMUM REQUIREMENTS

- A. All HPE equipment or hardware shall come from HPE or from authorized HPE reseller. Only with an active Hewlett Packard Enterprise (HPE) Partner ID.
- B. All HPE equipment shall be in proper condition, brand new and not refurbished or remanufactured with its original HPE packaging.
- C. All HPE equipment shall be running the safest and most up-to-date software specified in this Scope of work..
- D. All HPE equipment warranty shall cover the defects resulting from defective parts, materials, or manufacturing if such defects are revealed during the period of 6 months since the date of purchase or/and shall have hardware limited warranty option.
- E. For the defective parts under warranty, the vendor shall provide a return label. MTS will only send back the defective parts once we've received the replacement.
- F. HPE Brand or any HPE compatible products and services herein, is required to be with the highest level of quality standards and backed by warranty and shall be sourced through authorized HPE distributors.
- G. All HPE equipment shall be delivered in complete/full packages to the address specified under Section 4.9. In addition, the packages label shall specify the PO number.

### 4.3. SCOPE OF WORK/TECHNICAL SPECIFICATIONS (SEE ATTACHMENT 1)

### 4.4. [NOT APPLICABLE] BUY AMERICA

#### 4.1.1. [NOT APPLICABLE] CONSTRUCTION MATERIALS

#### 4.1.2. [NOT APPLICABLE] MANUFACTURED PRODUCT

#### 4.1.3. [NOT APPLICABLE] ROLLING STOCK

#### 4.1.4. [NOT APPLICABLE] IRON OR STEEL

### 4.5. INVOICES

Invoices must be sent to the MTS Accounting Department, via email, at [ap@sdmts.com](mailto:ap@sdmts.com). All invoices must have the Purchase Order and contract number clearly displayed to ensure timely payment. MTS will not pay on packing slips, receiving documents, delivery documents, or other similar documents. Invoices must be submitted for payment.

**Payment terms shall be net 30 days from invoice date.**

Contractors must also indicate if any of the invoiced amount(s) is for service or work provided by a subcontractor and indicate the amount that will be paid to the subcontractor. Contractors must also comply with the prompt payment requirements in the *Prompt Progress Payments* section of the Standard Conditions.

**4.6. [NOT APPLICABLE] MATERIAL SAFETY DATA SHEETS (MSDS)**

**4.7. WARRANTY**

Bidders shall outline in detail their warranty on the equipment offered, including the method of adjustment in cases of equipment, component or parts failure. Warranty shall also be stated for installation labor, materials, and method of adjustment.

**4.8. REPLACEMENT PARTS**

Replacement parts and technical support for the specified equipment must be guaranteed by the manufacturer; to be available for a ten (10) year period from the date of purchase. Manufacturer shall keep parts books and maintenance manuals up-to-date for that period.

**4.9. DELIVERY AND ACCEPTANCE**

Equipment or any deliverable provided under this contract shall be delivered F.O.B. to MTS, 100 16th Street, San Diego, California 92101 unless otherwise specified, in first class condition, complete and ready for operation, and the Contractor shall assume all responsibility and risk of loss incident to said delivery.

Contractor shall indicate delivery date on the Bid Form unless already specified, in which case, shall be made within the time set forth. Delivery is part of the consideration and must be adhered to as specified.

Contractor will not be held liable for failure to make delivery because of strikes, construction of property, governmental regulations, acts of God or any other causes beyond his control, provided a written extension of time is obtained from MTS.

Upon delivery, MTS will acknowledge receipt of said items or products. Delivery shall not constitute acceptance. Upon inspection and testing (if necessary) by MTS, a determination will be made whether said items or products are in conformance with contract requirements. If found in conformance, MTS shall approve the Contractor's invoice for payment; thereby constituting acceptance. Payment terms begin from this point. If the delivered items or products are found not in compliance, MTS will immediately notify the Contractor, and furnish all details of deficiencies. Contractor shall correct the deficiencies or supply new items or products (at the discretion of MTS) and resubmit for inspection and testing (if necessary).

**4.10. [NOT APPLICABLE] LIQUIDATED DAMAGES**

**4.11. [NOT APPLICABLE] ACQUISITION OF ROLLING STOCK**

**G2833.0-24 HPE Synergy for OCC - Bid Form**

MTS Doc. No. G2833.0-24

**Bidder Name: Nth Generation Computing, Inc.**

Cooperative Purchasing Program ref. number: (e.g.GSA, NASPO, CMAS, OMNI reference) if applicable: HPE pricing is in accordance with CA NASPO ValuePoint Contract #7-15-70-34-002.

\*Please specify the reference number of the Cooperative Purchasing Agreement used as the basis of your bid.

Item #	Product #	Item Description	Quantity	Unit of Measure	Unit Price	Extended Price
0100	P51174-B21	HPE Synergy 12000 Configure-to-order Frame ABA HPE Synergy 12000 CTO Frame	1	Each	\$ 3,241.00	\$ 3,241.00
0101	P39531-B21	HPE Synergy 480 Gen11 Configure-to-order Compute Module OD1 Factory Integrated	6	Each	\$ 1,712.00	\$ 10,272.00
0102	P49612-B21	Intel Xeon-Gold 5418Y 2.0GHz 24-core 185W Processor for HPE OD1 Factory Integrated	12	Each	\$ 1,867.00	\$ 22,404.00
0103	P43331-B21	HPE 64GB (1x64GB) Dual Rank x4 DDR5-4800 CAS-40-39-39 EC8 Registered Smart Memory Kit OD1 Factory Integrated	72	Each	\$ 1,201.00	\$ 86,472.00
0104	P39594-B21	HPE SY480 Gen11 Drive Less Kit OD1 Factory Integrated	6	Each	\$ 99.00	\$ 594.00
0105	P40513-B21	HPE 480GB NVMe Gen3 Mainstream Performance Read Intensive M.2 Multi Vendor SSD OD1 Factory Integrated	12	Each	\$ 260.00	\$ 3,120.00
0106	P39568-B21	HPE NS204i-d Gen11 Ctrlr Kit OD1 Factory Integrated	6	Each	\$ 124.00	\$ 744.00
0107	876449-B21	HPE Synergy 4820C 10/20/25Gb Converged Network Adapter OD1 Factory Integrated	6	Each	\$ 574.00	\$ 3,444.00
0108	P39587-B21	HPE SY480 Gen11 CPU Front HS Kit OD1 Factory Integrated	6	Each	\$ 166.00	\$ 996.00
0109	P39589-B21	HPE SY480 Gen11 CPU Rear HS Kit OD1 Factory Integrated	6	Each	\$ 186.00	\$ 1,116.00
0110	867796-B21	HPE Virtual Connect SE 100Gb F32 Module for Synergy OD1 Factory Integrated	2	Each	\$ 8,618.00	\$ 17,236.00
0111	882251-B21	HPE Synergy 100GbE/4x25GbE/4x32GbFC QSFP28 Transceiver OD1 Factory Integrated	2	Each	\$ 1,868.00	\$ 3,736.00
0112	876852-B21	HPE Synergy 4-port Frame Link Module OD1 Factory Integrated	2	Each	\$ 918.00	\$ 1,836.00
0113	453154-B21	HPE BladeSystem CClass Virtual Connect 1G SFP RJ45 Transceiver OD1 Factory Integrated	2	Each	\$ 126.00	\$ 252.00
0114	P44712-B21	HPE 1800W-2200W Flex Slot Titanium Hot Plug Low Halogen Power Supply Kit OD1 Factory Integrated	12	Each	\$ 363.00	\$ 4,356.00
0115	P51175-B21	HPE Synergy 12000 High Capacity Fan Kit OD1 Factory Integrated	10	Each	\$ 153.00	\$ 1,530.00
0116	804938-B21	HPE Synergy Frame Rack Rail Kit OD1 Factory Integrated	1	Each	\$ 114.00	\$ 114.00
0117	804943-B21	HPE Synergy Frame 4x Lift Handles OD1 Factory Integrated	1	Each	\$ 68.00	\$ 68.00
0118	872957-B21	HPE Synergy Composer2 Management Appliance OD1 Factory Integrated	2	Each	\$ 2,253.00	\$ 4,506.00
0119	P44074-B21	HPE Synergy Dual Slot Power Supply Adapter OD1 Factory Integrated	6	Each	\$ 125.00	\$ 750.00
0200	JD095C	HPE FlexNetwork X240 10G SFP+ to SFP+ 0.65m Direct Attach Copper Cable	2	Each	\$ 169.00	\$ 338.00
0300	817040R-B21	HPE Synergy 40GbE/4x10GbE/4x8Gb FC QSFP+ Remanufactured Transceiver	2	Each	\$ 831.00	\$ 1,662.00
0400	R3P67AAE	HPE Synergy 32Gb Fibre Channel Upgrade E-LTU	2	Each	\$ 1,500.00	\$ 3,000.00
0500	845406-B21	HPE 100Gb QSFP28 to QSFP28 3m Direct Attach Copper Cable	2	Each	\$ 203.00	\$ 406.00
0600	HU4A3A5	HPE 5Y Tech Care Critical Service	1	Each	\$ -	\$ -
	HU4A3A5	WJN HPE Synergy 1200 Frame Supp	1	Each	\$ 4,206.00	\$ 4,206.00
	HU4A3A5	ZIQ HPE Synergy Composer2 Support	2	Each	\$ 1,683.00	\$ 3,366.00
	HU4A3A5	ZIR HPE Synergy VC SE 100Gb F32 Module Supp	2	Each	\$ 3,969.00	\$ 7,938.00
	HU4A3A500ES	HPE SY480 Gen11 Support	6	Each	\$ 8,631.00	\$ 51,786.00
0700	K2Q46A	HPE Multi Fiber Push On to 4 x Lucent Connector 5m Cable	4	Each	\$ 195.00	\$ 780.00
0800	487655-B21	HPE BladeSystem c-Class 10GbE SFP+ to SFP+ 3m Direct Attach Copper Cable	2	Each	\$ 85.00	\$ 170.00
0900	H5UP2A1	HPE DC Integrat and Depl Pack SVC	1	Each	\$ -	\$ -
	H5UP2A1	003 HPE DC 50 Pack Integrat and Depl SVC	1	Each	\$ 14,250.00	\$ 14,250.00
1000	HA124A1	HPE Technical Installation Startup SVC	1	Each	\$ -	\$ -
	HA124A1	5ZM HPE Synergy First Frame Startup SVC	1	Each	\$ 15,945.00	\$ 15,945.00
Total Environmental Fee						\$ -
Sub-Total						\$ 270,634.00
Shipping						\$ -
<b>(BASIS OF AWARD) GRAND TOTAL (All Inclusive):</b>						<b>\$ 270,634.00</b>

**BIDDER ACCEPTS RESPONSIBILITY FOR ACCURACY AND PRESENTATION OF THE ABOVE NUMBERS.**

\*The above quantities are for bidding purposes only and are based on MTS' current usage. They represent what MTS anticipates as a requirement, but MTS does not guarantee this quantity. The actual quantity ordered may be more or less than what is anticipated on the pricing form, and it is dictated by MTS actual requirements and the available funding at the time each order is initiated.

**Bidders pricing should not include sales tax. MTS will add tax at PO issuance.**





Account Manager: Julie Leon

Email: julie.leon@nth.com

Inside Sales: Mifi Stewart

Email: mifi.stewart@nth.com

Email Orders To: orders@nth.com

Phone: 858-451-2383x118

Project #: 114012

Quote Date: 02/28/2024

Quote Expires: 03/29/2024

Quote #: 163218

**Quoted to:**

Dennis Conzemius  
San Diego Metropolitan Transit System  
100 16th St  
San Diego, CA 92101

**Ship to:****HPE Synergy OCC-6xSY480 Gen11 5Y**

PART#	QTY	DESCRIPTION	UNIT PRICE	EXT PRICE	TAX
CACONTR		HPE pricing is in accordance with CA NASPO ValuePoint Contract #7-15-70-34 -002.			
		<b><u>HPE Synergy Compute</u></b>			
P51174-B21	1	HPE Synergy 12000 Configure-to-order Frame	\$3,241.00	\$3,241.00	Y
P51174-B21:ABA	1	HPE Synergy 12000 CTO Frame			
P39531-B21	6	HPE Synergy 480 Gen11 Configure-to-order Compute Module	\$1,712.00	\$10,272.00	Y
P49612-B21	12	Intel Xeon-Gold 5418Y 2.0GHz 24-core 185W Processor for HPE	\$1,867.00	\$22,404.00	Y
P43331-B21	72	HPE 64GB (1x64GB) Dual Rank x4 DDR5 -4800 CAS-40-39-39 EC8 Registered Smart Memory Kit	\$1,201.00	\$86,472.00	Y
P39594-B21	6	HPE SY480 Gen11 Drive Less Kit	\$99.00	\$594.00	Y
P40513-B21	12	HPE 480GB NVMe Gen3 Mainstream Performance Read Intensive M.2 Multi Vendor SSD	\$260.00	\$3,120.00	Y
P39568-B21	6	HPE NS204i-d Gen11 Ctrlr Kit	\$124.00	\$744.00	Y
876449-B21	6	HPE Synergy 4820C 10/20/25Gb Converged Network Adapter	\$574.00	\$3,444.00	Y
P39587-B21	6	HPE SY480 Gen11 CPU Front HS Kit	\$166.00	\$996.00	Y
P39589-B21	6	HPE SY480 Gen11 CPU Rear HS Kit	\$186.00	\$1,116.00	Y
867796-B21	2	HPE Virtual Connect SE 100Gb F32 Module for Synergy	\$8,618.00	\$17,236.00	Y



Account Manager: Julie Leon

Email: julie.leon@nth.com

Inside Sales: Mifi Stewart

Email: mifi.stewart@nth.com

Email Orders To: orders@nth.com

Phone: 858-451-2383x118

Project #: 114012

Quote Date: 02/28/2024

Quote Expires: 03/29/2024

Quote #: 163218

**Quoted to:**

Dennis Conzemius  
San Diego Metropolitan Transit System  
100 16th St  
San Diego, CA 92101

**Ship to:****HPE Synergy OCC-6xSY480 Gen11 5Y**

PART#	QTY	DESCRIPTION	UNIT PRICE	EXT PRICE	TAX
882251-B21	2	HPE Synergy 100GbE/4x25GbE/4x32GbFC QSFP28 Transceiver	\$1,868.00	\$3,736.00	Y
876852-B21	2	HPE Synergy 4-port Frame Link Module	\$918.00	\$1,836.00	Y
453154-B21	2	HPE BladeSystem CClass Virtual Connect 1G SFP RJ45 Transceiver	\$126.00	\$252.00	Y
P44712-B21	12	HPE 1800W-2200W Flex Slot Titanium Hot Plug Low Halogen Power Supply Kit	\$363.00	\$4,356.00	Y
P51175-B21	10	HPE Synergy 12000 High Capacity Fan Kit	\$153.00	\$1,530.00	Y
804938-B21	1	HPE Synergy Frame Rack Rail Kit	\$114.00	\$114.00	Y
804943-B21	1	HPE Synergy Frame 4x Lift Handles	\$68.00	\$68.00	Y
872957-B21	2	HPE Synergy Composer2 Management Appliance	\$2,253.00	\$4,506.00	Y
P44074-B21	6	HPE Synergy Dual Slot Power Supply Adapter	\$125.00	\$750.00	Y
817040R-B21	2	HPE Synergy 40GbE/4x10GbE/4x8Gb FC QSFP+ Remanufactured Transceiver	\$831.00	\$1,662.00	Y
845406-B21	2	HPE 100Gb QSFP28 to QSFP28 3m Direct Attach Copper Cable	\$203.00	\$406.00	Y
K2Q46A	4	HPE Multi Fiber Push On to 4 x Lucent Connector 5m Cable	\$195.00	\$780.00	Y
487655-B21	2	HPE BladeSystem c-Class 10GbE SFP+ to SFP+ 3m Direct Attach Copper Cable	\$85.00	\$170.00	Y
JD095C	2	HPE Networking X240 10G SFP+ SFP+ 0.65m DAC Cable	\$169.00	\$338.00	Y



Account Manager: Julie Leon	Email: julie.leon@nth.com
Inside Sales: Mifi Stewart	Email: mifi.stewart@nth.com
Email Orders To: orders@nth.com	Phone: 858-451-2383x118

Project #: 114012      Quote Date: 02/28/2024      Quote Expires: 03/29/2024      Quote #: 163218

**Quoted to:**

Dennis Conzemius  
 San Diego Metropolitan Transit System  
 100 16th St  
 San Diego, CA 92101

**Ship to:**

**HPE Synergy OCC-6xSY480 Gen11 5Y**

PART#	QTY DESCRIPTION	UNIT PRICE	EXT PRICE	TAX
			\$170,143.00	

**Software**

R3P67AAE	2 HPE Synergy 32Gb Fibre Channel Upgrade E-LTU	\$1,500.00	\$3,000.00	N
			\$3,000.00	

**Support**

HU4A3A5	1 HPE 5Y Tech Care Critical Service			
HU4A3A5:WJN	1 HPE Synergy 1200 Frame Supp	\$4,206.00	\$4,206.00	N
HU4A3A5:Z1Q	2 HPE Synergy Composer2 Support	\$1,683.00	\$3,366.00	N
HU4A3A5:Z1R	2 HPE Synergy VC SE 100Gb F32 Module Supp	\$3,969.00	\$7,938.00	N
HU4A3A500ES	6 HPE SY480 Gen11 Support	\$8,631.00	\$51,786.00	N
			\$67,296.00	

**Services**

H5UP2A1	1 HPE DC Integrat and Depl Pack SVC			
H5UP2A1:003	1 HPE DC 50 Pack Integrat and Depl SVC	\$14,250.00	\$14,250.00	N
HA124A1	1 HPE Technical Installation Startup SVC			



Account Manager: Julie Leon	Email: julie.leon@nth.com
Inside Sales: Mifi Stewart	Email: mifi.stewart@nth.com
Email Orders To: orders@nth.com	Phone: 858-451-2383x118

Project #: 114012      Quote Date: 02/28/2024      Quote Expires: 03/29/2024      Quote #: 163218

**Quoted to:**

Dennis Conzemius  
 San Diego Metropolitan Transit System  
 100 16th St  
 San Diego, CA 92101

**Ship to:**

**HPE Synergy OCC-6xSY480 Gen11 5Y**

PART#	QTY DESCRIPTION	UNIT PRICE	EXT PRICE	TAX
HA124A1:5ZM	1 HPE Synergy First Frame Startup SVC	\$15,945.00	\$15,945.00	N
			\$30,195.00	

<b>Quote Subtotal</b>	<b>\$270,634.00</b>
<b>Tax Rate 7.750%</b>	<b>\$13,186.08</b>
<b>Est. Shipping *</b>	
<b>Payment Terms</b>	<b>UNDER REVIEW</b>
<b>TOTAL DUE</b>	<b>\$283,820.08</b>

\* Thank you for allowing Nth Generation to provide you with the above quotation. This quotation is the sole property of Nth Generation Computing, Inc. and is intended as an offer to sell goods and services to the client named in this quote.

Remit to: Same Address  
 DUNS #: 78-1123211  
 Federal ID #: 33-0451285  
 CAGE Code: 0YVL1  
 FOB: Destination  
 Ship Via: Fedex Ground/UPS / Your designated carrier  
 Terms: Net 30 (On Approved Credit)



**Metropolitan  
Transit  
System**

**DRAFT FOR EXECUTIVE COMMITTEE REVIEW DATE: 4/11/2024**

## **Agenda Item No. 11**

MEETING OF THE SAN DIEGO METROPOLITAN TRANSIT SYSTEM  
BOARD OF DIRECTORS

April 25, 2024

**SUBJECT:**

Occupational Health Services – Contract Award

**RECOMMENDATION:**

That the San Diego Metropolitan Transit System (MTS) Board of Directors:

- 1) Authorize the Chief Executive Officer (CEO) to execute MTS Doc. No. G2887.0-24 (in substantially the same format as Attachment A), with Concentra Medical Centers (Concentra), to provide occupational health services for a five (5) year base period with five (5) 1-year options, a total of ten (10) years, for a total contract cost of \$1,114,128.00;
- 2) Authorize the CEO to execute MTS Doc. No. G2888.0-24 (in substantially the same format as Attachment C), with Kaiser On-the-Job (Kaiser), to provide occupational health services for a five (5) year base period with five (5) 1-year options, a total of ten (10) years, for a total contract cost of \$1,351,200; and
- 3) Exercise options years at the CEO's discretion.

**Budget Impact**

The total cost of these contracts will not exceed \$2,465,328.00, this includes option years. The contracts will be funded by the Human Resources Operating account 711010-571160 and Employee Maintenance Operating account 711010-571170.

**DISCUSSION:**

MTS needs to retain one or more medical providers skilled in and familiarized with occupational medicine to perform comprehensive pre-placement, second opinion, and fit-for-duty medical examinations on employees or potential employees.

Department of Transportation (DOT) regulations require medical evaluations of employees, or potential employees, in "safety sensitive" positions and require that MTS conduct post-accident and reasonable suspicion drug testing.



For positions that are not regulated by the DOT, MTS requires pre-placement medical and physical examinations to assess the medical status of applicants selected for employment to ensure they are placed in positions appropriate to their abilities while minimizing the risk of future occupational injuries.

In accordance with applicable law, job applicants are examined only after receiving a job offer from MTS. Pre-placement examinations of all applicants consist of a detailed medical history questionnaire provided by MTS. The physician then reviews the medical history questionnaire, the job requirements as designated on the job specifications, and conducts the appropriate medical examination(s). A report is then provided to MTS's Human Resources Department, which assesses the individual's fitness to safely work in a particular job and identifies any necessary work restrictions caused by physical or psychological limitations.

The Department of Motor Vehicles (DMV) Medical Examiner Report is required by the State of California, pursuant to the United States DOT Public Safety Regulations (49 C.F.R. 391.41-391.49), to determine if a person is physically qualified to drive a commercial motor vehicle. In addition to DMV examinations for applicants for the Agency's bus and trolley operator and mechanic positions, MTS's current bus and trolley operator and maintenance employees are required to obtain DOT examination and recertification at least every two (2) years. The DMV examination is the same as the DOT examination for recertification. MTS requires that all physicals conducted on employees who will operate a revenue vehicle (e.g. Bus or Trolley) be performed by medical professionals certified as qualified by the Federal Motor Carrier Safety Administration ("FMCSA") and who are actively listed in the National Registry of Certified Medical Examiners.

MTS requires that all the successful Provider(s) coordinate and administer all testing necessary to complete employee physicals and determine if employees can safely perform their duties. For example, if sleep apnea testing (sleep study) is required by a Contractor, they must either administer the testing directly or retain a qualified subcontractor to perform the necessary testing.

On October 13, 2023, MTS issued a Request for Proposal (RFP) for Occupational Health Services on PlanetBids. MTS received a total of two (2) proposals on the due date of November 27, 2023, from the following firms:

Proposer	Firm Disadvantage Business Enterprise (DBE) or Small Business (SB) Certification
Concentra	N/A
Kaiser	N/A

All proposals were deemed responsive and responsible and were evaluated by a committee comprised of representatives from the MTS Human Resources and Finance Departments. The proposals were evaluated on the following:

- |  |             |
|--|-------------|
| 1. Qualifications of the Firm of Individual    | 20%         |
| 2. Staffing, Organization, and Management Plan | 25%         |
| 3. Work Plan                                   | 25%         |
| 4. Cost and Price                              | <u>30%</u>  |
| <b>Total</b>                                   | <b>100%</b> |

The following table illustrates the initial scores of the proposers:

PROPOSER	TOTAL COST (BASE + OPTION)	AVG COST SCORE	AVG TECH SCORE	TOTAL AVG SCORE (TOTAL POSSIBLE: 100)	RANKING
Concentra	\$1,130,160.00	28.33	55.83	84.16	1
Kaiser	\$5,908,020.00	2.67	53.17	55.84	2

As a result of the initial review, both firms were within the competitive range. MTS invited both firms for an interview, which were held virtually on January 10, 2024. After interviews and negotiations, staff was able to reduce Concentra’s cost proposal by \$16,032.00 (1.42%) and Kaiser’s cost proposal by \$4,556,820.00 (77.13%). Kaiser’s original cost proposal included a mathematical error and services not requested in the original scope of work. As a result, their revised cost proposal decreased significantly from their original cost proposal. The evaluation committee rescored both firms after as follows:

PROPOSER	TOTAL COST (BASE + OPTION)	AVG COST SCORE	AVG TECH SCORE	TOTAL AVG SCORE (TOTAL POSSIBLE: 100)	RANKING
Concentra	\$1,114,128.00	28.33	55.83	84.16	1
Kaiser	\$1,351,200.00	25.00	56.50	81.50	2

Based on the objectives of this procurement, consideration of the evaluation criteria and Concentra and Kaiser’s technical and cost proposals, the evaluation committee determined both Concentra and Kaiser presented the best value to MTS.

Therefore, staff recommends that the Board of Directors authorize the CEO to:

- 1) Authorize the CEO to execute MTS Doc. No. G2887.0-24 (in substantially the same format as Attachment A), with Concentra, to provide occupational health services for a five (5) year base period with five (5) 1-year options for a total contract cost of \$1,114,128.00;
- 2) Authorize the CEO to execute MTS Doc. No. G2888.0-24 (in substantially the same format as Attachment C), with Kaiser, to provide occupational health services for a five (5) year base period with five (5) 1-year options for a total contract cost of \$1,351,200; and
- 3) Exercise options years at the CEO’s discretion.

/s/ Sharon Cooney  
 Sharon Cooney  
 Chief Executive Officer

Key Staff Contact: Julia Tuer, 619.557.4515, [Julia.Tuer@sdmts.com](mailto:Julia.Tuer@sdmts.com)

- Attachments: A. Draft Agreement MTS Doc. No. G2887.0-24  
 B. Cost Proposal - G2887.0-24 - Concentra  
 C. Draft Agreement MTS Doc. No. G2888.0-24  
 D. Cost Proposal - G2888.0-24 - Kaiser



# Metropolitan Transit System

**STANDARD AGREEMENT  
FOR  
MTS DOC. NO. G2887.0-24  
OCCUPATIONAL HEALTH SERVICES**

THIS AGREEMENT is entered into this \_\_\_\_\_ day of \_\_\_\_\_, 2024 in the State of California by and between San Diego Metropolitan Transit System (“MTS”), a California public agency, and the following, hereinafter referred to as "Contractor":

Name: <u>Occupational Health Centers of California dba Concentra Medical Centers</u>	Address: <u>5575 Ruffin Road Suite 100</u>
	<u>San Diego CA 92123</u>
	City State Zip
Form of Business: <u>Corporation</u> (Corporation, Partnership, Sole Proprietor, etc.)	Email: <u><a href="mailto:kathy_le@concentra.com">kathy_le@concentra.com</a></u>
Telephone: <u>954-551-6763</u>	
Authorized person to sign contracts <u>Kathy Le</u>	<u>VP of Medical Operations – Pacific</u>
Name	Title

The Contractor agrees to provide services as specified in the conformed Scope of Work/Technical Specification (Exhibit A), Contractor’s Cost/Pricing Form (Exhibit B), and in accordance with the Standard Agreement, including Standard Conditions (Exhibit C), Forms (Exhibit D),

The contract term is for a five (5) year base period with five (5) 1-year options, exercisable at MTS’s sole discretion, for a total of ten (10) years. Base period shall be effective July 1, 2024 through June 30, 2029 and option years shall be effective July 1, 2029 through June 30, 2034, if exercised by MTS.

Payment terms shall be net 30 days from invoice date. The total cost of this contract shall not exceed \$532,140.00 for the base years and \$581,988.00 for the option years, for a contract total not to exceed \$1,114,128.00 without the express written consent of MTS.





SAN DIEGO METROPOLITAN TRANSIT SYSTEM	OCCUPATIONAL HEALTH CENTERS OF CALIFORNIA, DBA CONCENTRA MEDICAL CENTERS
By: _____ Sharon Cooney, Chief Executive Officer  Approved as to form:  By: _____ Karen Landers, General Counsel	By _____  Title: _____

DRAFT

**OCCUPATIONAL MEDICINE SERVICES**  
**MTS DOC. NO. G2887.0-24 (ref: IFB #G2786.0-24)**

**NAME OF FIRM:** Concentra Medical Centers

Service	Estimated quantity per month	# of months	Unit cost of service if performed at MTS worksite **	ITEM TOTAL	Unit cost of service if performed at offsite location	ITEM TOTAL
Physical DOT	72	12		\$0.00	\$65.00	\$56,160.00
Physical Non-DOT	5	12		\$0.00	\$59.00	\$3,540.00
Physical Fit For Duty	2	12		\$0.00	\$57.00	\$1,368.00
Physical Return To Work	1	12		\$0.00	\$75.00	\$900.00
Physical Basic	5	12		\$0.00	\$59.00	\$3,540.00
Pre-Employment Drug	20	12		\$0.00	\$31.00	\$7,440.00
Post Accident Breath	15	12		\$0.00	\$32.00	\$5,760.00
Post Accident Drug	15	12		\$0.00	\$31.00	\$5,580.00
Sleep Apena or other Specialty	3	12		\$0.00	\$454.00	\$16,344.00
Reasonable Suspicion Drug	1	12		\$0.00	\$31.00	\$372.00
Hep B Vaccine	2	12		\$0.00	\$226.00	\$5,424.00
<b>Base Year 1 Total</b>				<b>\$0.00</b>	<b>\$106,428.00</b>	

**\*\*Unit cost is the same as at offsite location price. Additional cost of personnel requested and billed hourly with a 4 hour minimum.**

Medical Assistant - \$85.00 per hour per hour	Midlevel provider - \$125.00 per hour	MD/DO \$185.00 per hour
---	---------------------------------------	-------------------------

Additional testing may be requested by the Agency based on the job classification or by the physician. The physician may not conduct any additional tests without the Agency's prior written approval. Additional testing may include, but is not limited to the following. Please provide unit costs for the following tests:

Additional Test	Unit Cost
Ishihara eye examination	\$ 34.00
Complete blood count	\$ 52.00
Hemoglobin and hemocrit	\$ 59.00
Blood chemistry panel	\$ 75.00
Range of motion – physical back exam	Included in PX exam
TB skin test	\$ 36.00
Lumbar spine X-ray	\$ 55.00
Chest X-ray	\$ 53.00
Pulmonary function test	\$ 44.00
Sleep study	\$ 454.00
Respirator Physical Exam	\$ 94.00

Proposer shall submit pricing to provide the services for all the work described. The unit cost shall be a total all-inclusive cost for each service. Estimated quantities are for proposal purposes only. The quantities do not reflect guaranteed usage by MTS, and may be more or less than estimated.

On the monthly billing MTS shall only pay for actual usage.

Proposer accepts responsibility for accuracy and presentation of the above numbers.

All proposers must complete proposal forms as provided, failure to do so will deem the proposal non-responsive.



# Metropolitan Transit System

## STANDARD AGREEMENT FOR MTS DOC. NO. G2888.0-24 OCCUPATIONAL HEALTH SERVICES

THIS AGREEMENT is entered into this \_\_\_\_\_ day of \_\_\_\_\_, 2024 in the State of California by and between San Diego Metropolitan Transit System (“MTS”), a California public agency, and the following, hereinafter referred to as "Contractor":

Name: Southern California Permanente Medical Group dba Kaiser Permanente On-the-Job Address: PO Box 741514

Form of Business: Partnership  
(Corporation, Partnership, Sole Proprietor, etc.)

Los Angeles CA 90074  
City State Zip

Email: [cheryl.l.finigan@kp.org](mailto:cheryl.l.finigan@kp.org)

Telephone: 818-518-4244

Authorized person to sign contracts Cheryl Finigan Executive Account Manager  
Name Title

The Contractor agrees to provide services as specified in the conformed Scope of Work/Technical Specification (Exhibit A), Contractor’s Cost/Pricing Form (Exhibit B), and in accordance with the Standard Agreement, including Standard Conditions (Exhibit C), Forms (Exhibit D).

The contract term is for a five (5) year base period with five (5) 1-year options, exercisable at MTS’s sole discretion, for a total of ten (10) years. Base period shall be effective July 1, 2024 through June 30, 2029 and option years shall be effective July 1, 2029 through June 30, 2034, if exercised by MTS.

Payment terms shall be net 30 days from invoice date. The total cost of this contract shall not exceed \$666,660.00 for the base years and \$684,540.00 for the option years, for a contract total not to exceed \$1,351,200.00 without the express written consent of MTS.



SAN DIEGO METROPOLITAN TRANSIT SYSTEM	SOUTHERN CALIFORNIA PERMANENTE MEDICAL GROUP, DBA KAISER PERMANENTE ON-THE-JOB
By: _____ Sharon Cooney, Chief Executive Officer Approved as to form: By: _____ Karen Landers, General Counsel	By _____ Title: _____

DRAFT

**OCCUPATIONAL MEDICINE SERVICES**  
**MTS DOC. NO. G2888.0-24 (ref: IFB #G2786.0-24)**

**NAME OF FIRM:** KPOJ

Service	Estimated quantity per month	# of months	Unit cost of service if performed at MTS worksite	ITEM TOTAL	Unit cost of service if performed at offsite location	ITEM TOTAL
Physical DOT	72	12		\$0.00	115	\$99,360.00
Physical Non-DOT	5	12		\$0.00	65	\$3,900.00
Physical Fit For Duty	2	12		\$0.00	95	\$2,280.00
Physical Return To Work	1	12		\$0.00	95	\$1,140.00
Physical Basic	5	12		\$0.00	65	\$3,900.00
Pre-Employment Drug	20	12		\$0.00	20	\$4,800.00
Post Accident Breath	15	12		\$0.00	30	\$5,400.00
Post Accident Drug	15	12		\$0.00	20	\$3,600.00
Sleep Apena or other Specialty	3	12		\$0.00	Referral	
Reasonable Suspicion Drug	1	12		\$0.00	20	\$240.00
Hep B Vaccine	2	12		\$0.00	363	\$8,712.00
<b>Base Year 1 Total</b>				<b>\$0.00</b>		<b>\$133,332.00</b>

*Additional testing may be requested by the Agency based on the job classification or by the physician. The physician may not conduct any additional tests without the Agency's prior written approval. Additional testing may include, but is not limited to the following. Please provide unit costs for the following tests:*

Additional Test	Unit Cost
Ishihara eye examination	\$ 25.00
Complete blood count	\$ 30.00
Hemoglobin and hemocrit	\$ 31.00
Blood chemistry panel	\$ 78.00
Range of motion – physical back	\$ 120.00
TB skin test	\$ 20.00
Lumbar spine X-ray	\$ 70.00
Chest X-ray	\$ 55.00
Pulmonary function test	\$ 35.00
Sleep study	\$ 240.00
Respirator Physical Exam	\$ 60.00

**\* Please review KPOJ's schedule A 1-5 years for employer choice and clinically indicated services.**

Proposer shall submit pricing to provide the services for all the work described. The unit cost shall be a total all-inclusive cost for each service. Estimated quantities are for proposal purposes only. The quantities do not reflect guaranteed usage by MTS, and may be more or less than estimated.

On the monthly billing MTS shall only pay for actual usage.

Proposer accepts responsibility for accuracy and presentation of the above numbers.

All proposers must complete proposal forms as provided, failure to do so will deem the proposal non-responsive.



**Metropolitan  
Transit  
System**

**DRAFT FOR EXECUTIVE COMMITTEE REVIEW DATE: 4/11/2024**

**Agenda Item No. 12**

MEETING OF THE SAN DIEGO METROPOLITAN TRANSIT SYSTEM  
BOARD OF DIRECTORS

April 25, 2024

**SUBJECT:**

Variable Messaging Sign (VMS) Media Converter & Cradlepoint Hardware – Contract Award

**RECOMMENDATION:**

That the San Diego Metropolitan Transit System (MTS) Board of Directors authorize the Chief Executive Officer (CEO) to execute MTS Doc. No. G2839.0-24 (in substantially the same format as Attachment A), with Datel Systems Incorporated (Datel), effective for five (5) years, for the purchase of network equipment, in the amount of \$402,481.00.

Budget Impact

The total cost of this contract is estimated to be \$402,481.00. This contract will be funded by the following Capital Improvement Program (CIP) accounts:

MTS CIP	General Ledger Account	CIP	Amount
Orange Line VMS	599902	2005119601	\$77,465.00
Blue Line VMS	599902	2007118701	\$56,310.00
Green Line VMS	599902	2007118701	\$83,515.00
Bus Rapid Transit (BRT) VMS	599902	1006122901	\$55,109.00
Mid-Coast VMS	599902	1006122901	\$42,975.00
Spares	599902	2007118701	\$87,107.00
<b>Total</b>			<b>\$402,481.00</b>

**DISCUSSION:**

MTS broadcasts next train arrivals, real-time alerts, and agency information to the public via the VMS system. The CIP includes projects to replace the VMS system (including 291 Daktronics and 95 Nanov signs that have reached their end-of-life usage) on each trolley line. Much of the technology and components for the system are outdated and unsupported or obsolete in some cases. The new equipment will maintain optimum performance and uptime. Today’s proposed action would replace the media converter and Cradlepoint hardware that is necessary for the VMS system to function.



Media converters and Cradlepoint routers are necessary to establish connectivity between each VMS unit and the MTS network at trolley stations and bus stops. A media converter is a networking device that converts ethernet or other communication protocols from one cable type to another (i.e., ensuring compatibility and integration between traditional cabling systems and newer high-speed fiber optic technologies). A Cradlepoint router is a networking device that provides reliable and secure internet connectivity for various environments, including remote locations like MTS's transit centers. This equipment is necessary to feed the information into the VMS system so that the signs can display information for our customers:

- Omnitron single mode media converters are required to provide communication from the MTS network to the VMS system. One pair of media converters is required for each VMS. One media converter is to be installed within the VMS and the second is installed in the network communications box found at the VMS's respective location.
- Omnitron powered chassis are needed for in the installation of media converters in communication boxes found on MTS property.
- Cradlepoint IBR600C units are required to provide wireless communication for VMS installed at locations where an MTS communications box is not found. Examples of such locations are bus stops on or near city sidewalks and property. One unit is needed per sign at these locations.

On January 24, 2024, MTS issued an Invitation for Bid (IFB) requesting bids for specified VMS media converters and Cradlepoint hardware. By the bid due date of February 20, 2024, MTS received a total of eleven (11) bids. The apparent lowest Bidder, Zones LLC, was deemed non-responsive due to incomplete bid submittal. Therefore, staff proceeded with the 2<sup>nd</sup> lowest responsive, responsible bidder, Datel. On March 5, 2024, MTS issued a Notice of Intent to Award (NIA) to Datel.

Based on the price comparison of the bids received, staff has determined Datel's pricing to be fair and reasonable.

Rank	Bidder	Minority Business Enterprise (MBE), Small Business (SB), Woman-Owned Business (WBE), Veteran-Owned Small Business (VOSB)	Bid Amount
1	Zones LLC *	N/A	\$ 160,808.90
<b>2</b>	<b>Datel Systems Incorporated</b>	<b>SB</b>	<b>\$ 402,481.00</b>
3	Hypertec USA Inc	SB	\$ 404,431.35
4	Graybar Electric, Inc	N/A	\$ 410,756.47
5	vPrime Tech Inc	MBE	\$ 419,629.97
6	Tech Micro USA	N/A	\$ 422,641.73
7	Questivity, Inc	DBE, MBE and SB	\$ 423,545.48
8	Kajeet, Inc	N/A	\$ 470,031.39
9	Wireless Investors, LLC	N/A	\$ 493,489.90
10	Expedition Communications, LLC	VOSB	\$ 606,668.00
11	SMART IT PROS INC	MBE and WBE	\$ 666,328.70

\*Non-responsive Bidder

Therefore, staff recommends that the MTS Board of Directors authorize the CEO to execute MTS Doc. No. G2839.0-24 (in substantially the same format as Attachment A), with Datel, effective for five (5) years, for the purchase of network equipment, in the amount of \$402,481.00.

/s/ Sharon Cooney  
Sharon Cooney  
Chief Executive Officer

Key Staff Contact: Julia Tuer, 619.557.4515, [Julia.Tuer@sdmts.com](mailto:Julia.Tuer@sdmts.com)

Attachments: A. Draft Agreement, MTS Doc. No. G2839.0-24  
B. Scope of Work  
C. Bid Form





# Metropolitan Transit System

## STANDARD AGREEMENT FOR

MTS DOC. NO. G2839.0-24

### VMS MEDIA CONVERTER & CRADLEPOINT HARDWARE

THIS AGREEMENT is entered into this \_\_\_\_\_ day of \_\_\_\_\_, 2024 in the State of California by and between San Diego Metropolitan Transit System (“MTS”), a California public agency, and the following, hereinafter referred to as "Contractor":

Name: Datel Systems Incorporated Address: 4393 Viewridge Ave. Suite C  
San Diego, CA 2123

Form of Business: Corporation  
 (Corporation, Partnership, Sole Proprietor, etc.) Email: [bbryant@datelsys.com](mailto:bbryant@datelsys.com)

Telephone: (424) 535-1018

Authorized person to sign contracts Bill Bryant VP of Sales  
 Name Title

The Contractor agrees to provide services with goods as specified in the conformed Scope of Work/Minimum Technical Specification (Exhibit A), Contractor’s Bid/Pricing Forms (Exhibit B), and in accordance with the Standard Agreement, including Standard Conditions (Exhibit C), Federal Requirements (Exhibit D), and Forms (Exhibit E).

The contract term is for five (5) years effective May 1, 2024 through April 28, 2028.

Payment terms shall be net 30 days from invoice date. The total cost of this contract (inclusive of CA 7.75% sales tax) shall not exceed \$402,481.00 without the express written consent of MTS.

SAN DIEGO METROPOLITAN TRANSIT SYSTEM	DATEL SYSTEMS INCORPORATED
By: <u>Sharon Cooney, Chief Executive Officer</u>	By _____
Approved as to form:	
By: <u>Karen Landers, General Counsel</u>	Title: _____



## **4. SCOPE OF WORK/TECHNICAL SPECIFICATIONS**

---

### **4.1. INTRODUCTION/BACKGROUND**

The San Diego Metropolitan Transit System (MTS) is soliciting quotes from vendors to supply paired media converters and Cradlepoint routers to be installed in Variable Message Signs (VMS) displays. This is a purchase and delivery only solicitation. Installation services will be performed by the VMS vendor and MTS. The units will be purchased in different phases over the life of the project and will be based on funding availability.

MTS is a public transit service that provides Bus and Trolley Services around San Diego County. MTS broadcasts next train/bus arrivals, real-time alerts and agency information to the public via the VMS system. Media converters and Cradlepoints are necessary to establish connectivity between each VMS unit and our network at trolley stations and bus stops.

### **4.2. SCOPE OF WORK**

Omnitron single mode media converters are required to provide communication from the MTS network to VMS signs. One pair of media converters is required for each VMS sign. One media converter is to be installed within the VMS sign and the second is installed in the network communications box found at the VMS sign's respective location.

Omnitron powered chassis are needed for in the installation of media converters in communication boxes found on MTS property.

Cradlepoint IBR600C units are required to provide wireless communication for the VMS signs installed at locations where a MTS communications box is not found. Examples of such locations are bus stops on or near city sidewalks and property. One unit is needed per sign at these locations.

The part numbers, minimum technical specifications/descriptions and quantities are shown in Attachment 1.

### **4.3. BUY AMERICA**

This scope of work may trigger Buy America and/or Build America Buy America requirements, which apply to construction materials, manufactured products, rolling stock, iron and steel. The below list of definitions and examples is not exhaustive and is only to be used as illustrative and a guidance tool for Contractor compliance.

#### **4.3.1. [NOT APPLICABLE] CONSTRUCTION MATERIALS**

#### **4.3.2. MANUFACTURED PRODUCT**

Per IJJA Section 70912 (2)(B), all manufactured products used in the project must be produced in the United States. Examples for manufactured products provided per Appendix A to 49 CFR 661.3 include: Infrastructure projects not made primarily of steel or iron, including structures (terminals, depots, garages, and bus shelters), ties and ballast; contact rail not made primarily of steel or iron; fare collection systems; computers; information systems; security systems; data processing systems; and mobile lifts, hoists, and elevators.

**4.3.3. [NOT APPLICABLE] ROLLING STOCK**

**4.3.4. [NOT APPLICABLE] IRON OR STEEL**

**4.4. INVOICES**

Invoices must be sent to the MTS Accounting Department, via email, at [ap@sdmts.com](mailto:ap@sdmts.com). All invoices must have the Purchase Order and contract number clearly displayed to ensure timely payment. MTS will not pay on packing slips, receiving documents, delivery documents, or other similar documents. Invoices must be submitted for payment.

**Payment terms shall be net 30 days from invoice date.**

Contractors must also indicate if any of the invoiced amount(s) is for service or work provided by a subcontractor and indicate the amount that will be paid to the subcontractor. Contractors must also comply with the prompt payment requirements in the *Prompt Progress Payments* section of the Standard Conditions.

**4.5. [NOT APPLICABLE] MATERIAL SAFETY DATA SHEETS (MSDS)**

**4.6. WARRANTY**

Bidders shall outline in detail their warranty on the equipment offered, including the method of adjustment in cases of equipment, component or parts failure. Warranty shall also be stated for installation labor, materials, and method of adjustment.

MTS shall have access, via telephone and/or email, to a vendor's representative during normal business hours when addressing concerns pertaining to delivery, invoicing, warranty support and configuration issues.

**4.7. REPLACEMENT PARTS**

Replacement parts and technical support for the specified equipment must be guaranteed by the manufacturer; to be available for a ten (10) year period from the date of purchase. Manufacturer shall keep parts books and maintenance manuals up-to-date for that period.

**4.8. DELIVERY AND ACCEPTANCE**

Equipment or any deliverable provided under this contract shall be delivered F.O.B. to SDTI, 1341 Commercial Street, San Diego, California 92113 and 5217 28<sup>th</sup> Ave, Rockford, IL 61109 unless otherwise specified, in first class condition, complete and ready for operation, and the Contractor shall assume all responsibility and risk of loss incident to said delivery.

One half of quantity ordered to be shipped to our VMS vendor and the other half of quantity ordered to be shipped to MTS. Delivery details to be provided once awarded.

Contractor shall indicate delivery date on the Bid Form unless already specified, in which case, shall be made within the time set forth. Delivery is part of the consideration and must be adhered to as specified.

Contractor will not be held liable for failure to make delivery because of strikes, construction of property, governmental regulations, acts of God or any other causes beyond his control, provided a written extension of time is obtained from MTS.

Upon delivery, MTS will acknowledge receipt of said items or products. Delivery shall not constitute acceptance. Upon inspection and testing (if necessary) by MTS, a determination will be made whether said items or products are in conformance with contract requirements. If found in conformance, MTS shall approve the Contractor's invoice for payment; thereby constituting acceptance. Payment terms begin from this point. If the delivered items or products are found not in compliance, MTS will immediately notify the Contractor, and furnish all details of deficiencies. Contractor shall correct the deficiencies or supply new items or products (at the discretion of MTS) and resubmit for inspection and testing (if necessary).

**4.9. [NOT APPLICABLE] LIQUIDATED DAMAGES**

**4.10. [NOT APPLICABLE] ACQUISITION OF ROLLING STOCK**

**VMS Media Converter & Cradlepoint Hardware - Bid Form**

MTS Doc. No. G2839.0-24

**Bidder Name:**                     Datel Systems Incorporated                    

Cooperative Purchasing Program ref. number: (e.g.GSA, NASPO, CMAS, OMNI reference) if applicable:

\*Please specify the reference number of the Cooperative Purchasing Agreement used as the basis of your bid.

Delivery lead time	Part Number	Item Description	Quantity	Unit of Measure	Unit Price	Extended Price
30 Days	Omnitron model: 4371-1W	Omnitron Media Converter (FlexPoint Gx, Gigabit Media Converter 1000BaseT -1000BaseLx SM/SC 1310nm 12km standalone with AC adapter and wide temp (-40°c to 60°c)	830	Each	\$ 390.00	\$ 323,700.00
30 Days	Omnitron model: 4395	Omnitron FlexPoint Powered Chassis (w. 2 Universal AC Power Supplies)	75	Each	\$ 875.00	\$ 65,625.00
5 Days	TB5-600C150M-NNN	5-yr NetCloud IoT Essentials Plan and IBR600C router with WiFi (150 Mbps modem)	22	Each	\$ 598.00	\$ 13,156.00
Sub-Total						\$ 402,481.00
Shipping						\$ -
<b>(BASIS OF AWARD) GRAND TOTAL (All Inclusive):</b>						<b>\$ 402,481.00</b>

**BIDDER ACCEPTS RESPONSIBILITY FOR ACCURACY AND PRESENTATION OF THE ABOVE NUMBERS.**

*\*The above quantities are for bidding purposes only and are based on MTS' current usage. They represent what MTS anticipates as a requirement, but MTS does not guarantee this quantity. The actual quantity ordered may be more or less than what is anticipated on the pricing form, and it is dictated by MTS actual requirements and the available funding at the time each order is initiated.*

**Bidders pricing should not include sales tax. MTS will add tax at PO issuance.**



**Metropolitan  
Transit  
System**

**DRAFT FOR EXECUTIVE COMMITTEE REVIEW DATE: 4/11/2024**

## **Agenda Item No. 13**

MEETING OF THE SAN DIEGO METROPOLITAN TRANSIT SYSTEM  
BOARD OF DIRECTORS

April 25, 2024

**SUBJECT:**

Iris Rapid Transit Center East and Bus Stops Construction - Contract Award

**RECOMMENDATION:**

That the San Diego Metropolitan Transit System (MTS) Board of Directors authorize the Chief Executive Officer (CEO) to:

- 1) Execute MTS Doc. No. PWB380.0-24 (in substantially the same format as Attachment A), with Hazard Construction Engineering LLC (Hazard Construction), for the Iris Rapid Transit Center East and Bus Stops Construction in the amount of \$4,410,884.00; and
- 2) Authorize the CEO to execute amendments or change orders up to a 15% contingency or \$661,632.60 for this construction contract, bringing total expenditure authority to \$5,072,516.60.

**Budget Impact**

The total cost for this contract is estimated to be \$5,072,516.60, which is the bid amount of \$4,410,884.00 plus 15% contingency. The project will be funded by MTS Capital Improvement Program (CIP) account 1009113001 - Iris Rapid Route and Station Infrastructure Improvements.

**DISCUSSION:**

In 2018, MTS staff applied for and received a Transit and Intercity Rail Capital Program (TIRCP) grant to add a new Rapid Bus feeder service between Imperial Beach and the Otay Mesa International Border crossing, connecting both communities to the UC San Diego Blue Line Trolley. Consistent with the grant program's goal to significantly reduce emissions of greenhouse gasses, the new rapid route is served by twelve (12) new, 60-foot Battery Electric Buses (BEB). The Iris Rapid service, also known as Rapid Route 227, started on October 15, 2023. The route operates at 7.5-min headways in the peak hours, with buses from the MTS South Bay Maintenance Facility (SBMF) on Main Street in Chula Vista.

MTS completed a route plan for Iris Rapid, which identified station stops along the route, and recommended upgrades at each location, including new shelters and Variable Message Signs (VMS) at the stops, and the addition of four (4) bus bays on the west side of the trolley tracks at the Iris Avenue Transit Center. On April 14, 2022 (Agenda Item (AI) 11), the MTS Board



approved the award of construction contract PWB342.0-22 to Palm Engineering Construction Company Inc. (Palm), for the Iris Rapid Route and Stations Infrastructure project (with an initial contract amount of \$4,202,276.80). In February 2023, due to concerns about the contractor's financial position and ability to perform, the contract was modified with a deductive change order to limit the work to the west bus island at the Iris Transit Center. Completion of the west bus islands allowed the service to begin in October 2023.

The final contract amounts for the Palm work related to the Iris Rapid Project were as follows:

	<b>Amount</b>	<b>Total w 10% contingency</b>	<b>Approval</b>
<b>BOARD APPROVAL</b>			
Base Bid	\$4,202,276.80	\$4,622,504.48	4/14/2022 (AI 11)
Add Alt 1 (South Bay Community Park Stop) NOT EXECUTED	\$176,974.60	\$194,672.06	4/14/2022 (AI 11)
<b>CONTRACTS ISSUED</b>			
	<b>Contract Amount</b>	<b>Board Approval Remaining</b>	<b>Contract Date</b>
PWB342.0-22 - Original Contract (Base Bid only)	\$4,202,276.80	\$420,227.68	5/3/2022
PWB342.1-22 (change order for City ROE permit and engineering costs)	\$29,671.37	\$390,556.31	1/30/2022
PWB342.2-22 (deductive change order to remove bus stop work, Iris Transit Center East, Eastern Traffic Signal work; SOW remaining: Iris Transit Center West, traffic signal modifications at Howard Ave & Iris Ave)	\$(2,514,518.35)	\$2,905,074.66	2/8/2023
PWB342.3-22 (change order for costs to cover materials and equipment already purchased for SOW before deductive change order)	\$97,575.71	\$2,807,498.95	6/28/2023
PWB342.4-22 (various change orders)	\$74,105.64	\$ 2,733,393.31	12/21/2023
<b>TOTALS</b>	<b>\$1,889,111.17</b>	<b>\$ 2,733,393.31</b>	

Staff then began working on a new Invitation for Bids (IFB) to find a new contractor to complete the portion of the scope of work that had been deducted from the Palm contract.

On November 9, 2023, staff issued the IFB. The Independent Cost Estimate (ICE) prepared by staff for the remaining scope of work was \$2,640,470. However, bid prices received in the two responses to the IFB on January 19, 2024 were significantly higher than the ICE:

<b>Iris Rapid Transit Center East and Bus Stops Construction Rebid IFB</b>				
Company Name	Firm Disadvantaged Business Enterprise (DBE)/Small Business (SB) Certification	8 Iris Rapid Bus Stops and Transit Center East Amount (Group A & B)	3 Additive Alternate Optional Bus Stops Amount <i>(Group C not exercising)</i>	Overall Total Bid Amount
MTS – Independent Cost Estimate (ICE)		\$2,096,860.00	\$543,610.00	\$2,640,470.00
<b>Hazard Construction</b>	<b>N/A</b>	<b>\$4,410,884.00</b>	\$1,072,287.00	<b>\$5,483,171.00</b>
SEMA Construction, Inc.	N/A	\$4,734,297.54	\$1,103,464.41	\$5,837,761.95

Notwithstanding his significant price increase over the ICE, MTS staff determined Hazard Construction’s price to be fair and reasonable. The primary basis for the ICE was the Palm bid from early 2022. Upon review of the above IFB bids, staff determined that the ICE was flawed for several reasons: (1) The 2022 Palm bid did not include the financial carrying costs required to procure materials in accordance with MTS’ construction contract (which was one of the reasons that Palm had difficulty completing the work under its original bid); (2) the state of California construction cost index (CCCI) shows a 9% increase between the two bid dates; and (3) the CCCI is general, covering all types of construction, including buildings, therefore the 9% increase is an average of all types of construction. The cost of steel has grown at a much higher rate than 9% since 2022. The steel increase is significant for this project as steel is used in all scopes of work: new shelters, VMS poles, rebar in concrete pavement, traffic signal arms and equipment, and other items. In addition, the actual bids received in the IFB process were very close and considered by staff to be an indication of the true “fair and reasonable” price for the work requested.

Hazard Construction will be utilizing one (1) subcontractor, Select Electric, a Minority Owned Business Enterprise (MBE), as detailed further in Attachment C.

Of note, the new scope of work for the remaining work related to the Iris Rapid Project includes the following project phases/options (Attachment B shows all the group details):

- Group A & B (to be executed upon Board approval) – 8 Iris Rapid Bus Stops, Traffic Signal modifications at Coronado Ave/Beyer Blvd/30<sup>th</sup>, and the Iris Transit Center East work
- Group C (deferred pending results of MTS outreach with Imperial Beach) – bus stop improvements on Westbound Imperial Beach Blvd & 3rd St, Westbound Imperial Beach Blvd & 8th St, and Westbound Imperial Beach Blvd & 13th St.

After implementation of the Route 227 service in October 2023, which includes routing down Third Street in the City of Imperial Beach (City), MTS received feedback from the City that local residents were requesting that the bus routing be changed from Third Street to Ninth Street. The City has requested that MTS conduct outreach about this potential change.<sup>1</sup> Therefore, under the proposed construction contract, any construction work at the bus stops associated

<sup>1</sup> The City’s request for MTS to re-route the Rapid 227 from Third Street to Ninth Street following outreach to residents on Ninth Street was discussed at the March 7, 2024 Executive Committee meeting (AI 4).



with the Third Street routing would only be included if MTS affirmatively exercises those options. This decision will be made after the MTS/City outreach about a potential route change.

**Today's Proposed Action**

Therefore, staff recommends that the MTS Board of Directors authorize the CEO to:

- 1) Execute MTS Doc. No. PWB380.0-24 (in substantially the same format as Attachment A), with Hazard Construction, for the Iris Rapid Transit Center East and Bus Stops Construction in the amount of \$4,410,884.00; and
- 2) Authorize the CEO to execute amendments or change orders up to a 15% contingency (\$661,632.60) for this construction contract, bringing total expenditure authority to \$5,072,516.60.

/s/ Sharon Cooney  
Sharon Cooney  
Chief Executive Officer

Key Staff Contact: Julia Tuer, 619.557.4515, [Julia.Tuer@sdmts.com](mailto:Julia.Tuer@sdmts.com)

Attachments: A. Draft Agreement, MTS Doc PWB380.0-24  
B. Bid Price Form  
C. Subcontractors



# Metropolitan Transit System

## STANDARD CONSTRUCTION AGREEMENT

FOR

MTS DOC. NO. PWB380.0-24

### IRIS RAPID TRANSIT CENTER EAST AND BUS STOPS CONSTRUCTION

THIS AGREEMENT is entered into this \_\_\_\_\_ day of \_\_\_\_\_ 2024, in the State of California by and between San Diego Metropolitan Transit System ("MTS"), a California public agency, and the following, hereinafter referred to as "Contractor":

Name: Hazard Construction Engineering LLC Address: 10529 Vine Street  
Lakeside, CA 92040

Form of Business: Corporation  
(Corporation, Partnership, Sole Proprietor, etc.) Email: Jmordhorst@hazardconstruction.com

Telephone: (858) 587-3600 x112

Authorized person to sign contracts	<u>Jason Mordhorst</u>	<u>President</u>
	Name	Title

**The specified Contract Documents are part of this Agreement. The Contractor agrees to furnish to MTS services and materials, as follows:**

Contractor shall furnish all necessary management, supervision, labor, materials, tools, supplies, equipment, plant, services, engineering, testing and/or any other act or thing required to diligently and fully perform and complete the Project as specified in accordance with the Standard Agreement and General Conditions (Exhibit A), Scope of Work, Special Conditions and Attachments (Exhibit B), Bid Price Form (Exhibit C), and Forms (Exhibit D).

#### SCOPE OF WORK

Contractor, for and in consideration of the payment to be made to Contractor as hereinafter provided, shall furnish all plant, labor, technical and professional services, supervision, materials and equipment, other than such materials and equipment as may be specified to be furnished by MTS, and perform all operations necessary to complete the Work in strict conformance with the Contract Documents (defined below) for the following public work of improvement:

#### IRIS RAPID TRANSIT CENTER EAST AND BUS STOPS CONSTRUCTION

Contractor is an independent contractor and not an agent of MTS. The Contractor and its surety shall be liable to MTS for any damages arising as a result of the Contractor's failure to comply with this obligation.



**CONTRACT TIME.**

Time is of the essence in the performance of the Work. The Work shall be commenced by the date stated in MTS’s Notice to Proceed. The Contractor shall complete all Work required by the Contract Documents within **300 calendar days** from the commencement date stated in the Notice to Proceed. By its signature hereunder, Contractor agrees the Contract Time is adequate and reasonable to complete the Work.

**CONTRACT PRICE.**

MTS shall pay the Contractor as full compensation for the performance of the Contract, subject to any additions or deductions as provided in the Contract Documents, and including all applicable taxes and costs, the sum of four million, four hundred ten thousand, eight hundred eighty-four dollars (\$4,410,884.00). Payment shall be made as set forth in the General Conditions.

**PROVISIONS REQUIRED BY LAW.**

Each and every provision of law required to be included in these Contract Documents shall be deemed to be included in these Contract Documents. The Contractor shall comply with all requirements of the California Labor Code applicable to this Project.

**INDEMNIFICATION.**

Contractor shall provide indemnification as set forth in the General Conditions.

**PREVAILING WAGES.**

Contractor shall be required to pay the prevailing rate of wages in accordance with the Labor Code which such rates shall be made available at MTS’s Administrative Office or may be obtained online at <http://www.dir.ca.gov> and which must be posted at the job site.

SAN DIEGO METROPOLITAN TRANSIT SYSTEM	HAZARD CONSTRUCTION ENGINEERING LLC
By: _____ Sharon Cooney, Chief Executive Officer  Approved as to form:  By: _____ Karen Landers, General Counsel	By _____   Title: _____



**ADDENDUM NO. 3 - IRIS RAPID BUS STOPS (GROUP A)**  
**EXCLUDES ADDITIVE ALTERNATE WB IB BLVD STOPS AT 3RD ST, 9TH ST, AND 13TH ST** Att.B, AI 13, 04/25/24

**Hazard**

ITEM	PAYMENT REFERENCE	LOCATION (WB/GB/SSP)	DESCRIPTION	UNIT	QUANTITY	UNIT PRICE	BUS STOP COST
<b>BASE BID</b>							
1	7-3.4.1	WB	Mobilization	LS	1.00	\$390,000.00	\$390,000.00
2	3-12.6.5	GB	Water Pollution Control	LS	1.00	\$200,000.00	\$200,000.00
3	300-1.3	SP	Clearing and Grubbing	LS	1.00	\$500,000.00	\$500,000.00
4	402-4	GB	Utility Relocations	LS	1.00	\$1.00	\$1.00
5	601-7	WB	Traffic Control and Engineered Traffic Control Plans	LS	1.00	\$470,000.00	\$470,000.00
6	301-7.2	SSP	Recycled Aggregate Base	CY	165	\$340.00	\$56,100.00
7	301-3.3.14	GB	Cement Treated Base	CY	21	\$750.00	\$15,750.00
8	302-5.9	SSP	Asphalt Concrete Pavement	TON	133	\$650.00	\$86,450.00
9	303-1.12	SSP	Type A Gravity Wall	CY	3	\$5,000.00	\$15,000.00
10	303-5.9	GB/WB	6" Concrete Curb & Gutter	LF	200	\$93.00	\$18,600.00
11	303-5.9	GB/WB	Concrete Bus Pad	CY	31	\$580.00	\$17,980.00
12	303-5.9	GB/WB	Concrete Sidewalk	SF	1,912	\$20.00	\$38,240.00
13	303-5.9	WB	Concrete Curb Ramp	EA	1	\$10,600.00	\$10,600.00
14	303-5.10	SSP	Stamped Colored Concrete	SF	220	\$56.00	\$12,320.00
15	309-4	WB	Thermoplastic Traffic Striping	LF	220	\$35.00	\$7,700.00
16	314-4.4.6	WB	Thermoplastic Pavement Markings	SF	75	\$25.00	\$1,875.00
17	314-4.4.6	WB	Continental Crosswalks	SF	200	\$32.00	\$6,400.00
<b>LIGHTING, TRAFFIC, ELECTRICAL, &amp; COMMUNICATIONS</b>							
18	701-2	SSP	Traffic Signal Modification - Coronado Ave / Beyer Blvd / 30th St	LS	1	\$400,000.00	\$400,000.00
19	701-2	SSP	Interconnect on Imperial Beach Blvd	LS	1	\$25,000.00	\$25,000.00
20	701-2	SSP	Bus Stop Electrical and Communication	LS	1	\$490,000.00	\$490,000.00
21	701-2	SSP	Pier Plaza Lighting	LS	1	\$61,000.00	\$61,000.00
22	1100-1.4	SSP	VMS Pole, Pedestal, and Foundation	EA	8	\$31,000.00	\$248,000.00
23	1100-3.4	SSP	Small Bus Shelter	EA	5	\$115,000.00	\$575,000.00
24	1100-4.4	SSP	Large Bus Shelter	EA	2	\$130,000.00	\$260,000.00
<b>*PERMITS AND LICENSES (NOT TO EXCEED \$20K ON THE BID FORM)</b>							
25	IFB SECTION 3.13		*Permits and Licenses (Not to exceed \$20K on the Bid Form)	EA	1	\$20,000.00	\$20,000.00
<b>TOTAL GROUP A</b>							<b>\$3,926,016.00</b>

GB = Greenbook Spec Reference, 2018 Edition

WB = City of San Diego Whitebook Spec Reference, 2018 Edition

SSP = Supplementary Special Provision Reference

**\*Permits and Licenses shall not exceed \$20,000 on the Bid Form.** Once the Agreement is fully executed, the project starts and the actual expenses for Permits and Licenses exceed \$20,000, MTS will issue a change order for the additional amount. However, if a bidder shows \$16,000 on their bid form, they will bear the cost of any overage, which will be \$4,000 (\$20,000 - \$16,000), if the actual expenses exceed \$16,000. The change order will only be issued if the costs surpass \$20,000. Therefore it is bidder's responsibility to bid accordingly. □

**MTS WILL AWARD ONE (1) CONTRACT. BIDDERS MUST BID ON ALL GROUPS A, B, & C IN ORDER TO BE DEEMED RESPONSIVE.**

**BASIS FOR AWARD WILL BE THE OVERALL TOTAL FOR GROUP A + GROUP B + GROUP C.**



### ADDENDUM NO. 3 - TRANSIT CENTER EAST (GROUP B)

Hazard							
ITEM	PAYMENT REFERENCE	LOCATION (WB/GB/SSP)	DESCRIPTION	UNIT	QUANTITY	UNIT PRICE	IRIS TC EAST COST
<b>BASE BID</b>							
1	7-3.4.1	WB	Mobilization	LS	1.00	\$40,000.00	\$40,000.00
2	3-12.6.5	GB	Water Pollution Control	LS	1.00	\$20,000.00	\$20,000.00
3	300-1.3	SP	Clearing and Grubbing	LS	1.00	\$35,000.00	\$35,000.00
4	402-4	GB	Utility Relocations	LS	1.00	\$5,000.00	\$5,000.00
5	601-7	WB	Traffic Control and Engineered Traffic Control Plans	LS	1.00	\$20,000.00	\$20,000.00
<b>CIVIL / SITE IMPROVEMENTS</b>							
6	301-2.4	GB	Crushed Aggregate Base	CY	66	\$160.00	\$10,560.00
7	303-1.12	SSP	Install VMS Foundation (No Pole/Pedestal)	EA	1	\$9,000.00	\$9,000.00
8	303-5.9	GB/WB	6" Concrete Curb & Gutter	LF	243	\$56.00	\$13,608.00
9	303-5.9	GB/WB	6" Concrete Curb	LF	31	\$50.00	\$1,550.00
10	303-5.9	GB/WB	Concrete Bus Pad	CY	41	\$430.00	\$17,630.00
11	303-5.9	GB/WB	Concrete Cross Gutter (6')	SF	210	\$11.00	\$2,310.00
12	303-5.9	GB/WB	Concrete Sidewalk	SF	1,390	\$10.00	\$13,900.00
13	303-5.9	WB	Concrete Curb Ramp	EA	1	\$3,200.00	\$3,200.00
14	304-6	WB	Relocate Sign	EA	3	\$870.00	\$2,610.00
<b>LIGHTING, TRAFFIC, ELECTRICAL, &amp; COMMUNICATIONS</b>							
15	701-2	SSP	Transit Center Electrical, Communication, and Lighting	LS	1	\$245,000.00	\$245,000.00
<b>TRANSIT CENTER &amp; BUS STOP FURNISHINGS</b>							
16	1100-1.4	SSP	VMS Pole, Pedestal, and Foundation	EA	1	\$28,000.00	\$28,000.00
17	1100-5.1	SSP	Relocate Bus Shelters & Benches	LS	1	\$7,500.00	\$7,500.00
<b>*PERMITS AND LICENSES (NOT TO EXCEED \$10K ON THE BID FORM)</b>							
18	IFB SECTION 3.13		*Permits and Licenses (Not to exceed \$10K on the Bid Form)	EA	1	\$10,000.00	\$10,000.00
<b>TOTAL GROUP B</b>							<b>\$484,868.00</b>

GB = Greenbook Spec Reference, 2018 Edition

WB = City of San Diego Whitebook Spec Reference, 2018 Edition

SSP = Supplementary Special Provision Reference

**\*Permits and Licenses shall not exceed \$10,000 on the Bid Form.** Once the Agreement is fully executed, the project starts and the actual expenses for Permits and Licenses exceed \$10,000, MTS will issue a change order for the additional amount. However, if a bidder shows \$7,000 on their bid form, they will bear the cost of any overage, which will be \$3,000 (\$10,000 - \$7,000), if the actual expenses exceed \$7,000. The change order will only be issued if the costs surpass \$10,000. Therefore it is bidder's responsibility to bid accordingly.

**MTS WILL AWARD ONE (1) CONTRACT. BIDDERS MUST BID ON ALL GROUPS A, B, & C IN ORDER TO BE DEEMED RESPONSIVE.**

**BASIS FOR AWARD WILL BE THE OVERALL TOTAL FOR GROUP A + GROUP B + GROUP C.**



**ADDENDUM NO. 3 - IRIS RAPID BUS STOPS ADDITIVE ALTERNATES (GROUP C)**  
**WB IB BLVD STOPS AT 3RD ST, 9TH ST, AND 13TH ST**

**Hazard (NOT EXERCISING ALTERNATE)**

ITEM	PAYMENT REFERENCE	LOCATION (WB/GB/SSP)	DESCRIPTION	UNIT	QUANTITY	UNIT PRICE	BUS STOP COST
<b>BASE BID</b>							
1	7-3.4.1	WB	Mobilization	LS	1.00	\$85,000.00	\$85,000.00
2	3-12.6.5	GB	Water Pollution Control	LS	1.00	\$10,000.00	\$10,000.00
3	300-1.3	SP	Clearing and Grubbing	LS	1.00	\$45,000.00	\$45,000.00
4	402-4	GB	Utility Relocations	LS	1.00	\$1.00	\$1.00
5	601-7	WB	Traffic Control and Engineered Traffic Control Plans	LS	1.00	\$50,000.00	\$50,000.00
6	201-6	GB	2 Sack Slurry	CY	19	\$350.00	\$6,650.00
7	301-7.2	SSP	Recycled Aggregate Base	CY	56	\$300.00	\$16,800.00
8	302-5.9	SSP	Asphalt Concrete Pavement	TON	45	\$500.00	\$22,500.00
9	303-5.9	GB/WB	6" Concrete Curb & Gutter	LF	70	\$60.00	\$4,200.00
10	303-5.9	GB/WB	Concrete Sidewalk	SF	188	\$22.00	\$4,136.00
<b>LIGHTING, TRAFFIC, ELECTRICAL, &amp; COMMUNICATIONS</b>							
11	701-2	SSP	Bus Stop Electrical and Communication	LS	1	\$440,000.00	\$440,000.00
12	1100-1.4	SSP	VMS Pole, Pedestal, and Foundation	EA	3	\$26,000.00	\$78,000.00
13	1100-3.4	SSP	Small Bus Shelter	EA	3	\$100,000.00	\$300,000.00
<b>*PERMITS AND LICENSES (NOT TO EXCEED \$10K ON THE BID FORM)</b>							
14	IFB SECTION 3.13		*Permits and Licenses (Not to exceed \$10K on the Bid Form)	EA	1	\$10,000.00	\$10,000.00
<b>TOTAL GROUP C</b>							<b>\$1,072,287.00</b>

GB = Greenbook Spec Reference, 2018 Edition

WB = City of San Diego Whitebook Spec Reference, 2018 Edition

SSP = Supplementary Special Provision Reference

**\*Permits and Licenses shall not exceed \$10,000 on the Bid Form.** Once the Agreement is fully executed, the project starts and the actual expenses for Permits and Licenses exceed \$10,000, MTS will issue a change order for the additional amount. However, if a bidder shows \$7,000 on their bid form, they will bear the cost of any overage, which will be \$3,000 (\$10,000 - \$7,000), if the actual expenses exceed \$7,000. The change order will only be issued if the costs surpass \$10,000. Therefore it is bidder's responsibility to bid accordingly.

**MTS WILL AWARD ONE (1) CONTRACT. BIDDERS MUST BID ON ALL GROUPS A, B, & C IN ORDER TO BE DEEMED RESPONSIVE.**  
**BASIS FOR AWARD WILL BE THE OVERALL TOTAL FOR GROUP A + GROUP B + GROUP C.**



**ADDENDUM NO. 3 - OVERALL TOTAL GROUP A + B + C (BASIS FOR AWARD)**

<b>TOTAL SUMMARY</b>	<b>Hazard</b>	<b>Notes</b>
IRIS RAPID BUS STOPS (GROUP A)	\$3,926,016.00	AWARDING
TRANSIT CENTER EAST COSTS (GROUP B)	\$484,868.00	AWARDING
IRIS RAPID BUS STOPS ADDITIVE ALTERNATES (GROUP C)	\$1,072,287.00	NOT EXERCISING ALTERNATES
<b>OVERALL TOTAL GROUP A + B + C (BASIS FOR AWARD)</b>	<b>\$5,483,171.00</b>	

Subcontractor							Any time there is a change to a Subcontractor resubmit this attachment. Any change to these forms after bid submittal must be made in accordance with Public Contract Code sections 4100 et seq., as applicable, and as permitted by MTS.						
Company Name	Type of DBE	% of Work	DIR Number	Dollar Value	Description of Work	Point of Contact First Name	Point of Contact Last Name	Email	Phone Number	Street Address	City	State	Zip
SELECT ELECTRIC, INC.	N/A	31.1%	1000001036	\$ 1,705,000	ELECTRICAL, TRAFFIC SIGNALS, LIGHTING & RELATED	LONDON	SMITH	LSMITH@SELECTELECTRICINC.COM	760-477-2013	2790 BUSINESS PARK DR.	VISTA	CA	92081





**Metropolitan  
Transit  
System**

**DRAFT FOR EXECUTIVE COMMITTEE REVIEW DATE: 4/11/2024**

## **Agenda Item No. 14**

MEETING OF THE SAN DIEGO METROPOLITAN TRANSIT SYSTEM  
BOARD OF DIRECTORS

April 25, 2024

**SUBJECT:**

Design Services for Iris Rapid Route and Station Infrastructure Improvements – Work Order Amendment

**RECOMMENDATION:**

That the San Diego Metropolitan Transit System (MTS) Board of Directors:

- 1) Ratify Work Order WOA353-AE-19, under MTS Doc No. PWL353.0-22 (Attachment A), with Dokken Engineering (Dokken), in the amount of \$111,611.05 to provide additional project management, new bid package development and support services, additional design support during construction, and prepare as-built drawings;
- 2) Ratify Work Order WOA353-AE-19.01, under MTS Doc No. PWL353.0-22 (Attachment B), with Dokken, in the amount of \$16,813.67 to provide temporary construction easement extensions; and
- 3) Authorize the Chief Executive Officer (CEO) to approve Amendment WOA353-AE-19.02, under MTS Doc No. PWL353.0-22 (in substantially the same format as Attachment C), with Dokken, in the amount of \$117,746.82 to provide additional project management, local agency processing, fiber optic design and San Diego Gas & Electric (SDG&E) coordination, bid package preparation and bid support, design support during construction, and as-built drawings.

**Budget Impact**

The total contract cost is estimated to be \$246,171.54. The project will be funded by the Capital Improvement Project (CIP) account 1009113001 - Iris Rapid Route and Station Infrastructure Improvements.

**DISCUSSION:**

In 2018, MTS staff applied for and received a Transit and Intercity Rail Capital Program (TIRCP) grant to add a new Rapid Bus feeder service between Imperial Beach and the Otay Mesa International Border crossing, connecting both communities to the UC San Diego Blue Line

**1255 Imperial Avenue, Suite 1000, San Diego, CA 92101-7490 • (619) 231-1466 • [sdmts.com](http://sdmts.com)**

San Diego Metropolitan Transit System (MTS) is a California public agency comprised of San Diego Transit Corp., San Diego Trolley, Inc. and San Diego and Arizona Eastern Railway Company (nonprofit public benefit corporations). MTS member agencies include the cities of Chula Vista, Coronado, El Cajon, Imperial Beach, La Mesa, Lemon Grove, National City, Poway, San Diego, Santee, and the County of San Diego. MTS is also the For-Hire Vehicle administrator for nine cities.



Trolley. Consistent with the grant program’s goal to significantly reduce emissions of greenhouse gasses, the new rapid route is served by twelve (12) new, 60-foot Battery Electric Buses (BEB). The Iris Rapid service, also known as Rapid Route 227, started on October 15, 2023. The route operates at 7.5-min headways in the peak hours, with buses from the MTS South Bay Maintenance Facility (SBMF) on Main Street in Chula Vista.

The Iris Rapid project includes station stops along the route, and recommended upgrades at each location, including new shelters and Variable Message Signs (VMS) at the stops, and the addition of four (4) bus bays on the west side of the trolley tracks at the Iris Avenue Transit Center.

Construction on the project started after the Board approved a contract with Palm Engineering Construction Company, Inc. on April 14, 2022 (Agenda Item (AI) 11). However, due to the contractor’s inability to complete construction of the full project, the project was de-scoped and the contractor only completed construction of the west bus island. This allowed MTS to launch and operate the new Iris Rapid Transit Service on time. In order to complete construction of the remaining route bus stops and the east bus island, the project had to be re-designed and re-bid as a second phase.

A project of this kind requires design services throughout each phase. Here, on July 30, 2020 (AI 12), the Board approved issuance of a work order to Dokken for design services for the Iris Rapid Route and Station Infrastructure Improvements. Dokken was chosen following a request for proposals process to approved Architectural and Engineering (A&E) firms on MTS’s On-Call A&E Panel. Various amendments and additional funding have been issued to Dokken during the life of this project. Because MTS’s On-Call A&E Panel expired during the course of this project, work orders were issued under two different on-call master agreements, depending on the time of execution.

The table below provides a summary of design costs for the Iris Rapid Route and Station Infrastructure Improvements:

<b>Work Order No.</b>	<b>Purpose</b>	<b>Amount</b>	<b>Board Approval Date</b>
<b>MTS Doc. No. G2075.0-18 Master Agreement with Dokken</b>			
WOA2075-AE-54	Original Work Order	\$647,270.61	7/30/20, Item 12
WOA2075-AE-54.01	Amendment 1 – Right-of-Way Support	\$96,513.63	Approved by the CEO 4/20/21
WOA2075-AE-54.02	Amendment 2 – Curb Ramp Design	\$10,254.73	11/18/21, Item 13
<b>MTS Doc. No. PWL353.0-22 Master Agreement with Dokken</b>			
WOA353-AE-19	New Work Order - Iris route and station improvements Re-bid	\$111,611.05	Approved by the CEO 4/13/23 (Att. A)
WOA353-AE-19.01	Amendment 1 – Temporary Construction Easement Extensions	\$16,813.67	Approved by the CEO 8/29/23 (Att. B)

WOA353-AE-19.02	Amendment 2 – Additional design and plan updates for re-bid	\$117,746.82	Today’s proposed action (Att. C)
<b>Grand Total:</b>		<b>\$1,000,210.51</b>	

As the project is now separated into two phases, the Iris Rapid West Bus Island (phase 1) and the Iris Rapid Route Bus Stops and East Bus Island (phase 2), the Design Support During Construction (DSDC) funding was utilized during the first phase, and additional design services, bid support, and DSDC are needed for phase 2.

Today’s proposed action will approve Work Order WOA353-AE-19.02 with Dokken to provide additional project management, local agency processing, fiber optic design and SDG&E coordination, bid package preparation and bid support, design support during construction, and as-built drawings.

Therefore, the staff recommends that the MTS Board of Directors:

- 1) Ratify Work Order WOA353-AE-19, under MTS Doc No. PWL353.0-22 (Attachment A), with Dokken, in the amount of \$111,611.05 to provide additional project management, new bid package development and support services, additional design support during construction, and prepare as-built drawings;
- 2) Ratify Work Order WOA353-AE-19.01, under MTS Doc No. PWL353.0-22 (Attachment B), with Dokken, in the amount of \$16,813.67 to provide temporary construction easement extensions; and
- 3) Authorize the CEO to approve Amendment WOA353-AE-19.02, under MTS Doc No. PWL353.0-22 (in substantially the same format as Attachment C), with Dokken, in the amount of \$117,746.82 to provide additional project management, local agency processing, fiber optic design and SDG&E coordination, bid package preparation and bid support, design support during construction, and as-built drawings.

/s/ Sharon Cooney  
 Sharon Cooney  
 Chief Executive Officer

Key Staff Contact: Julia Tuer, 619.557.4515, [Julia.Tuer@sdmts.com](mailto:Julia.Tuer@sdmts.com)

- Attachments: A. Executed Work Order, MTS Doc No. WOA353-AE-19  
 B. Executed Work Order, MTS Doc No. WOA353-AE-19.01  
 C. Draft Work Order, MTS Doc No. WOA353-AE-19.02



**Metropolitan  
Transit  
System**

March 31, 2023

MTS Doc. No. PWL353.0-22  
WOA353-AE-19

Mr. John Klemunes, PE  
Regional Manager  
Dokken Engineering  
1450 Frazee Road, Suite 100  
San Diego, CA 92108

Dear Mr. Klemunes:

**Subject: WORK ORDER WOA353-AE-19, TO MTS DOC. NO. PWL353.0-22, ENGINEERING SERVICES FOR IRIS RAPID CORRIDOR AND STATION DESIGN**

This letter shall serve as Work Order WOA353-AE-19, under the General Engineering Consultant Agreement, MTS Doc. No. PWL353.0-22, as further described below.

#### SCOPE OF SERVICES

This Work Order shall provide design services for Iris Rapid Corridor and Station Design project for the facilitation of the amendment to the existing construction contract, and support the new bid solicitation for construction services at the transit stops along the corridor. (Attachment A).

(This work order agreement is continuation of services under Consultant's previous work order number WOA2075-AE-54, to MTS Doc No. G2075.0-18.)

#### SCHEDULE

The Scope of Services shall remain in effect through the completion of construction from the date of the Notice to Proceed.

#### PAYMENT

Payment shall be based on actual costs in the amount of \$111,611.05, and shall not be exceeded without prior authorization of MTS (Attachment B).



Please sign below, and return the document to the Contracts Specialist at MTS. All other terms and conditions shall remain the same and in effect.

Sincerely,

Accepted:

Sharon Cooney Digitally signed by Sharon Cooney  
Date: 2023.04.13 13:16:40 -0700

Sharon Cooney  
Chief Executive Officer



John Klemunes, PE  
Regional Manager, Dokken Engineering

Date: 4/13/2023

Attachments: Attachment A, Scope of Services  
Attachment B, Negotiated Fee Proposal

ATTACHMENT A  
SCOPE OF SERVICES

## I. SCOPE OF SERVICES

The MTS Iris Rapid Corridor and Station Design project is proposed to be split into two construction contracts. The existing construction contract will be amended to only include the work at the Iris Transit Center. A new solicitation will be prepared for the remaining work at the transit stops along the corridor. Dokken Engineering (DE) will provide the following Scope of Services to facilitate the amendment to the existing construction contract as well as support the new solicitation:

### **TASK 15: Additional Project Management**

DE will provide project management services that will include monthly progress reports, invoicing and administration of the project over the additional anticipated 8-month construction and closeout period.

### **TASK 16: New Bid Package Development and Support Services**

DE will assist MTS in analyzing the existing construction contract and the proposal to split the project into two contracts. DE will review contractor quantities and proposed pricing for the construction change order.

DE will prepare a new bid package that splits the original construction project into two projects. One project will consist of the work at the Iris Transit Center and the other will consist of the work at the individual transit stops. The new bid package will consist of the work at the individual transit stops. DE will prepare a ready to bid package consisting of plans, specifications and estimate. DE will also coordinate with the City of San Diego regarding the changes to the plan package.

DE will attend the pre-bid meeting and respond to Request for Information (RFI's) during the bidding process.

### **TASK 17: Additional Design Support During Construction**

Additional Design Support during construction is required for the project due to the schedule extension and splitting the original construction project into two contracts. The following are included in construction support tasks

**Attend Construction Meetings** - DE shall have one representative attend construction team meetings.

**Review and Approve Contractor Submittals** – DE shall review and approve or take other appropriate action as necessary in response to Contractor-prepared submittals required by the specifications, but only for conformance with the information given in the Contract Documents. These submittals include shop drawings, product catalog cut sheets, certificates of compliance, samples, and other data which the Contractor is required to submit. Such review and approvals or other action shall not extend to means, methods, techniques, equipment choice and usage, sequences, schedules or procedures of construction and related safety precautions and programs by the Contractor.

**Respond to Requests for Information (RFI)** – DE shall review and respond to Contractor RFIs forwarded from the Construction Manager (CM) or MTS Project Manager and issue necessary clarifications and interpretations of the Contract Documents as appropriate for the orderly completion of the Contractor's work. Any orders authorizing variations from the Contract Documents will be made by the CM.

**Field Observation and Contract Change Orders** – At the request of MTS, DE shall

conduct site visits to respond to RFI's, develop Change Orders, and/or perform other specific tasks.

**TASK 18: As-Built Drawings**

Consultant shall prepare as-built drawings based on redline drawings provided by the Contractor. The as-built drawings will be submitted and processed through the City of San Diego and the City of Imperial Beach.

**II. DELIVERABLES**

New Bid Package, RFI's, CCO's and Material Reviews  
As-Built Drawings

**III. PERIOD OF PERFORMANCE**

The Scope of Services shall remain in effect through the completion of construction from the date of the Notice to Proceed

**IV. MATERIALS TO BE PROVIDED BY DOKKEN and/or MTS**

N/A

**V. SPECIAL CONDITIONS/ASSUMPTIONS**

Any condition listed below applies solely to this Task Order and does not otherwise alter the Agreement or other Task Orders. The Scope and Fees are based on the following assumptions.

- A. This task order will be limited to the time and materials fee budget negotiated as shown in Attachment B.
- B. All deliverables will be provided in electronic format.

**VI. MTS ACCEPTANCE OF SERVICES:**

Contractor shall not be compensated at any time for unauthorized work outside of this Work Order. Contractor shall provide notice to MTS' Project Manager upon 100% completion of this Work Order. Within five (5) business days from receipt of notice of Work Order completion, MTS' Project Manager shall review, for acceptance, the 100% completion notice. If Contractor provides final service(s) or final work product(s) which are found to be unacceptable due to Contractors and/or Contractor's subcontractors negligence and thus not 100% complete by MTS' Project Manager, Contractor shall be required to make revisions to said service(s) and/or work product(s) within the Not to Exceed (NTE) Budget. MTS reserves the right to withhold payment associated with this Work Order until the Project Manager provides written acceptance for the 100% final completion notice. Moreover, 100% acceptance and final completion will be based on resolution of comments received to the draft documents and delivery of final documentation which shall incorporate all MTS revisions and comments.

Monthly progress payments shall be based on hours performed for each person/classification identified in the attached Fee Schedule and shall at no time exceed the NTE. Contractor shall only be compensated for actual performance of services and at no time shall be compensated for services for which MTS does not have an accepted deliverable or written proof and MTS acceptance of services performed.



## **VII. DEFICIENT WORK PRODUCT:**

Throughout the construction management and/or implementation phases associated with the services rendered by the Contractor, if MTS finds any work product provided by Contractor to be deficient and the deficiently delays any portion of the project, Contractor shall bear the full burden of their deficient work and shall be responsible for taking all corrective actions to remedy their deficient work product including but not limited to the following:

- Revising provided documents,

At no time will MTS be required to correct any portion of the Contractors deficient work product and shall bear no costs or burden associated with Contractors deficient performance and/or work product.

## **VIII. DELIVERABLE REQUIREMENTS**

Contractor will be required to submit any and all documentation required by the Scope of Work. The deliverables furnished shall be of a quality acceptable to MTS. The criteria for acceptance shall be a product of neat appearance, well-organized, and procedurally, technically and grammatically correct. MTS reserves the right to request a change in the format if it doesn't satisfy MTS's needs. All work products will become the property of MTS. MTS reserves the right to disclose any reports or material provided by the Contractor to any third party.

Contractor shall provide with each task, a work plan showing the deliverables schedule as well as other relevant date needed for Contractor's work control, when and as requested by MTS.

Contractor's computer data processing and work processing capabilities and data storage should be compatible with Windows compatible PC's, text files readable in Microsoft Word, and standard and customary electronic storage. Contractor shall maintain backup copies of all data conveyed to MTS.

Contractor shall provide MTS with hard copy or electronic versions of reports and/or other material as requested by MTS.

## **IX. PRICING**

Except where otherwise noted herein, pricing shall be firm and fixed for the duration of the Work Order and any subsequent Change Orders/Amendments to the Work Order. There shall be no escalation of rates or fees allowed.

ATTACHMENT B  
NEGOTIATED FEE PROPOSAL

# Work Order Estimate Summary

Att.A, AI 14, 04/25/24

<b>MTS Doc. No.</b>	<b>PWL353.0-22</b>
<b>Work Order No.</b>	<b>WOA353-AE-19</b>
<b>Attachment:</b>	<b>B</b>

**Work Order Title:** MTS Iris Rapid Corridor & Station Design

**Project No:** TBD

**Table 1 - Cost Codes Summary (Costs & Hours)**

Item	Cost Codes	Cost Codes Description	Total Costs
1	Labor	Direct Labor	\$ 111,611.05
2	ODC	Other Direct Costs	\$ -

Totals = \$111,611.05

**Table 2 - TASKS/WBS Summary (Costs & Hours)**

Item	TASKS/WBS	TASKS/WBS Description	Labor Hrs	Total Costs
1	Task 15	Additional Project Management	40	\$ 11,960.40
2	Task 16	New Bid Package Development and Support Services	110	\$ 18,274.10
3	Task 17	Additional Design Support During Construction	360	\$ 70,018.10
4	Task 18	As-Built Drawings	75	\$ 11,358.45

Totals = 585 \$111,611.05

**Table 3 - Consultant/Subconsultant Summary (Costs & Hours)**

(If Applicable, Select One)				Consultant	Labor Hrs	Total Costs
DBE	DVBE	SBE	Other			
				Dokken Engineering	585	\$ 111,611.05

Totals = 585 \$ 111,611.05

# Work Order Estimate Summary

Att.A, AI 14, 04/25/24

Total Hours =	585
Total Costs =	\$111,611.05

Dokken Engineering

MTS Doc. No.: **PWL353.0-22**  
 Work Order No.: **WOA353-AE-19**

MTS Iris Rapid Corridor & Station Design

Attachment: **B**

Item	TASKS/WBS	TASKS/WBS Description	ODCs (See Attachment)	Contract Manager	Engineer - Senior	Engineer - 3	Engineer - 1	Total Hours	Totals
				\$ 299.01	\$ 202.46	\$ 169.80	\$ 111.07		
<b>15</b>	<b>Task 15</b>	<b>Additional Project Management</b>							
15.1	Additional Project Management			40				40	\$11,960.40
		Subtotals (Hours) =	N/A	40				40	\$11,960.40
		Subtotals (Costs) =		\$11,960.40				<b>40</b>	<b>\$11,960.40</b>
<b>16</b>	<b>Task 16</b>	<b>New Bid Package Development and Support Services</b>							
16.1	New Bid Package Development and Support Services			10	20	40	40	110	\$18,274.10
		Subtotals (Hours) =	N/A	10	20	40	40	110	\$18,274.10
		Subtotals (Costs) =		\$2,990.10	\$4,049.20	\$6,792.00	\$4,442.80	<b>110</b>	<b>\$18,274.10</b>
<b>17</b>	<b>Task 17</b>	<b>Additional Design Support During Construction</b>							
17.1	Attend Construction Meetings			50		50		100	\$23,440.50
17.2	Review and Approve Contractor Submittals			20	30	40	40	130	\$23,288.80
17.3	Respond to Requests for Information			20	30	40	40	130	\$23,288.80
		Subtotals (Hours) =	N/A	90	60	130	80	360	\$70,018.10
		Subtotals (Costs) =		\$26,910.90	\$12,147.60	\$22,074.00	\$8,885.60	<b>360</b>	<b>\$70,018.10</b>
<b>18</b>	<b>Task 18</b>	<b>As-Built Drawings</b>							
18.1	As-Built Drawings			5	10	20	40	75	\$11,358.45
		Subtotals (Hours) =	N/A	5	10	20	40	75	\$11,358.45
		Subtotals (Costs) =		\$1,495.05	\$2,024.60	\$3,396.00	\$4,442.80	<b>75</b>	<b>\$11,358.45</b>
								<b>585</b>	<b>\$111,611.05</b>
		<b>Totals (Summary) =</b>						<b>585</b>	<b>\$111,611.05</b>
		Total (Hours) = N/A		145	90	190	160	585	\$111,611.05
		Total (Costs) =		\$43,356.45	\$18,221.40	\$32,262.00	\$17,771.20		
		Percentage of Total (Hours) = N/A		25%	15%	32%	27%		
		Percentage of Total (Costs) =		39%	16%	29%	16%		

# Work Order Estimate Summary

Att.A, AI 14, 04/25/24

Consultant/ Subconsultant:

Contract No:

Work Order Title:

Task Order No:

Attachment:

### TASKS/WBS (1-5)

ODC Item	Description	Unit	Unit Cost	Task 1		Task 2		Task 3		Task 4		Task 5	
				Quantity	Total	Quantity	Total	Quantity	Total	Quantity	Total	Quantity	Total
1													
2													
3													
4													
5													
6													
7													
8													
9													
10													

Subtotal =     Subtotal =     Subtotal =     Subtotal =     Subtotal =

### TASKS/WBS (6-10)

ODC Item	Description											Totals	
		Quantity	Total	Quantity	Total	Quantity	Total	Quantity	Total	Quantity	Total	Quantity	Total
1													
2													
3													
4													
5													
6													
7													
8													
9													
10													

Subtotal =     Subtotal =     Subtotal =     Subtotal =     Subtotal =     Totals =



# Metropolitan Transit System

August 16, 2023

MTS Doc. No. PWL353.0-22  
WOA353-AE-19.01

John Klemunes  
PE Regional Manager  
Dokken Engineering  
1450 Frazee Road, Suite 100  
San Diego, CA 92108

Dear John Klemunes:

Subject: AMENDMENT NO. 1 TO WORK ORDER WOA353-AE-19, TO MTS DOC. NO. PWL353.0-22, ENGINEERING SERVICES FOR IRIS RAPID CORRIDOR AND STATION DESIGN

This letter shall serve as Amendment No. 1 to Work Order WOA353-AE-19, under the General Engineering Consultant Agreement, MTS Doc. No. PWL353.0-22, as further described below.

### SCOPE OF SERVICES

This Amendment adds Task 19 for temporary construction easement extensions to the Work Order for Iris Rapid Corridor and Station Design project. (Attachment A).

### SCHEDULE

There shall be no change to the Schedule as a result of this Amendment. The Scope of Services shall remain in effect through the completion of construction from the date of the Notice to Proceed.

### PAYMENT

As a result of this Amendment, the Payment shall be increased by \$16,813.67 (Attachment B). Payment shall be based on actual costs in the revised amount of \$128,424.72, and shall not be exceeded without prior authorization of MTS.

Please sign below, and return the document to the Contracts Specialist at MTS. All other terms and conditions shall remain the same and in effect.

Sincerely,

Sharon Cooney  
Chief Executive Officer

Accepted:

John Klemunes, PE  
Regional Manager, Dokken Engineering  
*President*

Date:

*8/29/2023*

Attachments: A. Scope of Services  
B. Negotiated Fee Proposal



ATTACHMENT A  
SCOPE OF SERVICES

**TITLE:** MTS “Iris Rapid” – Corridor & Station Design      **WOA #:** WOA353-AE-19.01

## **I. PROJECT DESCRIPTION**

The MTS Iris Rapid Corridor and Station Design project’s Temporary Construction Easements are set to expire in August 2023 and October 2023. This amendment covers right of way support services to process an eighteen (18) month extension for those two easements

## **II. SCOPE OF WORK**

The scope of work shall consist of the following tasks and deliverables:

### **TASK 19: Temporary Construction Easement Extensions**

#### **TASK 19.1 Waiver Valuations in Lieu of Appraisals**

Dokken will complete Waiver Valuations for Temporary Construction Easement (TCE) extensions on parcels 633-031-24 and 627-302-32. In insignificant valuation situations an appraisal may be waived [49 CFR 24.102(c) (2)]. Dokken’s right of way team has experience in doing waiver valuations on numerous projects, and this allows the budget and schedule to remain on track for projects with accelerated timelines. Waiver Valuations follow Caltrans and Uniform Act guidelines.

- Deliverables: 2 Waiver Valuations

#### **TASK 19.2 Temporary Construction Easement Extension Coordination**

TCEs were previously acquired on two (2) properties (633-031-24 and 627-302-32) and will expire on October 31, 2023 and August 31, 2023, respectively. Since construction will extend beyond the original TCE timeline, we have budgeted for the additional effort required to extend this TCE.

After completion of the valuation and just compensation determination, Dokken will prepare the TCE Extension offer package. The offer package will include the offer letter, written summary of just compensation with supporting valuation information, Title VI information, and “Your Property – Your Transportation Project” booklet. Dokken will prepare the Amendment to the Temporary Construction Easement and will negotiate with the property owner to arrive at a mutually agreeable.

Dokken’s Right of Way Agents hold California Real Estate Salesperson’s Licenses and are working under the direct supervision of a California Real Estate Licensed Broker.

- Deliverables: Temporary Construction Easement Extensions, Administrative Settlements, and Acquisition Diaries

#### **Task 19.3 Payment Coordination**

Upon reaching an agreement with the property owner, Dokken will be available to assist MTS in paying the owner directly and recording the TCE amendments with the County. Dokken will work closely with MTS to assist in the timely closing of all transactions.

- Deliverables: Recorded Easements

## **III. DELIVERABLES**

Two (2) Waiver Valuations, TCE Extensions, Administrative Settlements, Acquisition Diaries, Recorded Easements



**IV. SCHEDULE OF SERVICES/MILESTONES/DELIVERABLES**

Deliverables will be provided during the period of construction (6/1/2023-10/31-2023).

**V. SPECIAL CONDITIONS**

Any condition listed below applies solely to this Work Order and does not otherwise alter the Agreement or other Work Orders.

- A. This task order will be limited to the time and materials fee budget negotiated as shown in Attachment B.
- B. All deliverables will be provided in electronic format.

ATTACHMENT B  
NEGOTIATED FEE PROPOSAL

# Work Order Estimate Summary

Att.B, AI 14, 04/25/24

<b>MTS Doc. No.</b>	<b>PWL353.0-22</b>
<b>Work Order No.</b>	<b>WOA353-AE-19.01</b>
<b>Attachment:</b>	<b>B</b>

**Work Order Title:** MTS Iris Rapid Corridor & Station Design - Amendment  
1

**Project No:** TBD

**Table 1 - Cost Codes Summary (Costs & Hours)**

Item	Cost Codes	Cost Codes Description	Total Costs
1	Labor	Direct Labor	\$16,813.67
2	ODC	Other Direct Costs	

Totals = \$16,813.67

**Table 2 - TASKS/WBS Summary (Costs & Hours)**

Item	TASKS/WBS	TASKS/WBS Description	Labor Hrs	Total Costs
1	Task 19	Temporary Constrction Easement Extensions	115	\$16,813.67

Totals = 115 \$16,813.67

**Table 3 - Consultant/Subconsultant Summary (Costs & Hours)**

(If Applicable, Select One)				Consultant	Labor Hrs	Total Costs
DBE	DVBE	SBE	Other			
				Dokken Engineering	115	\$16,813.67

Totals = 115 \$16,813.67

# Work Order Estimate Summary

Att.B, AI 14, 04/25/24

Total Hours =	115
Total Costs =	\$16,813.67

Dokken Engineering

MTS Doc. No.: **PWL353.0-22**  
 Work Order No.: **WOA353-AE-19.01**

MTS Iris Rapid Corridor & Station Design -  
Amendment 1

**Attachment: B**

Item	TASKS/WBS	TASKS/WBS Description	ODCs (See Attachment)	Contract Manager	Technical Expert	Technician	Total Hours	Totals
				\$ 299.01	\$ 161.47	\$ 74.75		
<b>19</b>	<b>Task 19</b>	<b>Temporary Constrction Easement Extensions</b>						
19.1	Waiver Valuations in Lieu of Appraisals			1	22	15	38	\$4,972.60
19.2	Temporary Construction Easement Extension Coordination			1	60	5	66	\$10,360.96
19.3	Payment Coordination			1	5	5	11	\$1,480.11
		Subtotals (Hours) =	N/A	3	87	25	115	\$16,813.67
		Subtotals (Costs) =		\$897.03	\$14,047.89	\$1,868.75	<b>115</b>	<b>\$16,813.67</b>

**Totals (Summary) =**

	<b>115</b>	<b>\$16,813.67</b>
--	------------	--------------------

Total (Hours) = N/A	3	87	25	115	\$16,813.67
Total (Costs) =	\$897.03	\$14,047.89	\$1,868.75		

Percentage of Total (Hours) = N/A	3%	76%	22%		
Percentage of Total (Costs) =	5%	84%	11%		



**Metropolitan  
Transit  
System**

April 25, 2024

MTS Doc. No. PWL353.0-22  
WOA353-AE-19.02

Mr. John Klemunes, PE  
Regional Manager  
Dokken Engineering  
1450 Frazee Road, Suite 100  
San Diego, CA 92108

Dear Mr. Klemunes:

**Subject: AMENDMENT NO. 2 TO WORK ORDER WOA353-AE-19, TO MTS DOC. NO. PWL353.0-22, ENGINEERING SERVICES FOR IRIS RAPID CORRIDOR AND STATION DESIGN**

This letter shall serve as Amendment No. 2 to Work Order WOA353-AE-19, under the General Engineering Consultant Agreement, MTS Doc. No. PWL353.0-22, as further described below.

#### SCOPE OF SERVICES

This Amendment provides additional project management, local agency processing, fiber optic design and SDG&E coordination, bid package preparation and bid support, design support during construction, and as-built drawings for the Iris Rapid Corridor and Station Design project. (Attachment A).

#### SCHEDULE

There shall be no change to the Schedule as a result of this Amendment. The Scope of Services shall remain in effect through the anticipated completion of construction - January 2025 - from the date of the Notice to Proceed.

#### PAYMENT

As a result of this Amendment, the Payment shall be increased by \$117,746.82 (Attachment B). Payment shall be based on actual costs in the revised amount of \$246,171.54, and shall not be exceeded without prior authorization of MTS.



Please sign below, and return the document to the Contracts Specialist at MTS. All other terms and conditions shall remain the same and in effect.

Sincerely,

Accepted:

Sharon Cooney  
Chief Executive Officer

\_\_\_\_\_  
John Klemunes, PE  
Regional Manager, Dokken Engineering

Date: \_\_\_\_\_

Attachments: Attachment A, Scope of Services  
Attachment B, Negotiated Fee Proposal

DRAFT

ATTACHMENT A  
SCOPE OF SERVICES

DRAFT

**TITLE:** MTS “Iris Rapid” – Corridor & Station Design

**WOA #:** WOA353-AE-19.02

## **I. PROJECT DESCRIPTION**

Consultant shall provide the following Scope of Services to help facilitate the implementation and construction contract for the MTS Iris bus stops and transit center east work.

## **II. SCOPE OF WORK**

The scope of work shall consist of the following tasks and deliverables:

### **TASK 20: Additional Project Management**

Consultant shall provide project management services that will include monthly progress reports, invoicing and administration of the project through construction and closeout period.

### **TASK 21: Additional Local Agency Processing**

Consultant shall prepare and process a new construction package through the City of San Diego Development Services Department (DSD) and the City of Imperial Beach to obtain new permits. Consultant shall coordinate with both Local Agencies to address comments and revise plans as needed.

### **TASK 22: Fiber Optic Design and SDG&E Coordination**

Consultant shall update the fiber optic plans to extend the fiber installation from Imperial Beach Blvd up 2nd Street and Elder Street to lifeguard station. Consultant shall provide field element schematic along the fiber route showing breakout fibers for each bus stop variable message sign (VMS) and prepare a detail of the fiber termination and landing at the Dempsey Center Lifeguard Station.

Consultant shall update the project plans and continue coordination with SDG&E for changes to their service points. These updates shall also be included in the plan sets processed with the local agencies.

### **TASK 23: Bid Package Preparation and Bid Support**

Consultant shall compile a new bid package utilizing the approved local agency permit sets and updated fiber optic drawings. Consultant shall attend the pre-bid meeting and respond to Request for Information (RFI's) during the bidding process.

### **TASK 24: Additional Design Support During Construction**

Additional design support during construction is required for the project due to the schedule extension and splitting the original construction project into two contracts. The following are included in construction support tasks:

**24.01 Attend Construction Meetings** - Consultant shall have one representative attend construction team meetings.

**24.02 Review and Approve Contractor Submittals** – Consultant shall review and approve or take other appropriate action as necessary in response to Contractor-prepared submittals required by the specifications, but only for conformance with the information given in the Contract Documents. These submittals include shop drawings, product catalog cut sheets, certificates of compliance, samples, and other data which the Contractor is required to submit. Such review and approvals or other action shall not extend to means, methods, techniques, equipment choice and usage, sequences, schedules or procedures of construction and related safety precautions and programs by the Contractor.



**24.03 Respond to RFIs** – Consultant shall review and respond to Contractor RFIs forwarded from the Construction Manager (CM) or MTS Project Manager and issue necessary clarifications and interpretations of the contract documents as appropriate for the orderly completion of the Contractor's work. Any orders authorizing variations from the contract documents will be made by the CM.

**24.04 Field Observation and Contract Change Orders (CCOs)** – At the request of MTS, Consultant shall conduct site visits to respond to RFI's, develop Change Orders, and/or perform other specific tasks.

**TASK 25: As-Built Drawings**

Consultant shall prepare as-built drawings based on redline drawings provided by the Contractor. The as-built drawings will be submitted and processed through the City of San Diego and the City of Imperial Beach.

**III. DELIVERABLES**

New fiber optic design, new local agency permits, RFI's, CCO's and Material Reviews  
As-Built Drawings.

**IV. SCHEDULE OF SERVICES/MILESTONES/DELIVERABLES**

Deliverables will be provided during the anticipated construction period of 3/1/2024-1/2025.

**V. SPECIAL CONDITIONS**

Any condition listed below applies solely to this Work Order and does not otherwise alter the Agreement or other Work Orders.

- A. This task order will be limited to the time and materials fee budget negotiated as shown in Attachment B.
- B. All deliverables will be provided in electronic format.

ATTACHMENT B  
NEGOTIATED FEE PROPOSAL

DRAFT

# Work Order Estimate Summary

Att.C, AI 14, 04/25/24

MTS Doc. No. **PWL353.0-22**

Work Order No. **WOA353-AE-19.02**

Attachment: **B**

Work Order Title: **MTS Iris Rapid Corridor & Station Design - Amendment 2**

Project No:

**Table 1 - Cost Codes Summary (Costs & Hours)**

Item	Cost Codes	Cost Codes Description	Total Costs
1	Labor	Direct Labor	\$117,746.82
2	ODC	Other Direct Costs	

Totals = **\$117,746.82**

**Table 2 - TASKS/WBS Summary (Costs & Hours)**

Item	TASKS/WBS	TASKS/WBS Description	Labor Hrs	Total Costs
1	Task 20	Additional Project Management	60	\$15,044.10
2	Task 21	Additional Local Agency Processing	42	\$6,542.02
3	Task 22	Fiber Optic Design and SDG&E Coordination	55	\$8,876.35
4	Task 23	Bid Package Preparation and Bid Support	65	\$11,161.65
5	Task 24	Additional Design Support During Construction	355	\$64,764.25
6	Task 25	As-Built Drawings	75	\$11,358.45

Totals = **652** **\$117,746.82**

**Table 3 - Consultant/Subconsultant Summary (Costs & Hours)**

(If Applicable, Select One)				Consultant	Labor Hrs	Total Costs
DBE	DVBE	SBE	Other			
				Dokken Engineering	652	\$117,746.82

Totals = **652** **\$117,746.82**

## Work Order Estimate Summary

Att.C, AI 14, 04/25/24

Total Hours =	652
Total Costs =	\$117,746.82

Dokken Engineering

MTS Doc. No.: **PWL353.0-22**

Work Order No.: **WOA353-AE-19.02**

MTS Iris Rapid Corridor & Station Design - Amendment 2

Attachment: **B**

Item	TASKS/WBS	TASKS/WBS Description	ODCs (See Attachment)	Contract Manager	Task Manager	Engineer - Senior	Engineer -3	Engineer -2	Engineer - 1	CADD - Senior	Technical Expert	Technician - 2	Total Hours	Totals
				\$ 299.01	\$ 212.00	\$ 202.46	\$ 169.80	\$ 150.11	\$ 111.07	\$ 191.37	\$ 161.47	\$ 74.75		
20	<b>Task 20</b>	<b>Additional Project Management</b>												
20.1	Additional Project Management			30		30							60	\$15,044.10
	ODCs													
		Subtotals (Hours) =	N/A	30		30							60	\$15,044.10
		Subtotals (Costs) =		\$8,970.30		\$6,073.80							<b>60</b>	<b>\$15,044.10</b>
21	<b>Task 21</b>	<b>Additional Local Agency Processing</b>												
21.1	Additional Local Agency Processing			2		10	10		20				42	\$6,542.02
	ODCs													
		Subtotals (Hours) =	N/A	2		10	10		20				42	\$6,542.02
		Subtotals (Costs) =		\$598.02		\$2,024.60	\$1,698.00		\$2,221.40				<b>42</b>	<b>\$6,542.02</b>
22	<b>Task 22</b>	<b>Fiber Optic Design and SDG&amp;E Coordination</b>												
22.1	Fiber Optic Design and SDG&E Coordination			5		20			30				55	\$8,876.35
	ODCs													
		Subtotals (Hours) =	N/A	5		20			30				55	\$8,876.35
		Subtotals (Costs) =		\$1,495.05		\$4,049.20			\$3,332.10				<b>55</b>	<b>\$8,876.35</b>
23	<b>Task 23</b>	<b>Bid Package Preparation and Bid Support</b>												
23.1	Bid Package Preparation and Bid Support			5		20	20		20				65	\$11,161.65
	ODCs													
		Subtotals (Hours) =	N/A	5		20	20		20				65	\$11,161.65
		Subtotals (Costs) =		\$1,495.05		\$4,049.20	\$3,396.00		\$2,221.40				<b>65</b>	<b>\$11,161.65</b>
24	<b>Task 24</b>	<b>Additional Design Support During Construction</b>												
24.1	Attend Construction Meetings			40		10	40		10				100	\$21,887.70
24.2	Review and Approve Contractor Submittals			10		20	40		40				110	\$18,274.10
24.3	Respond to Requests for Information			10		20	40		40				110	\$18,274.10
24.4	Field Observation and Contract Change Orders			5		10	10		10				35	\$6,328.35
	ODCs													
		Subtotals (Hours) =	N/A	65		60	130		100				355	\$64,764.25
		Subtotals (Costs) =		\$19,435.65		\$12,147.60	\$22,074.00		\$11,107.00				<b>355</b>	<b>\$64,764.25</b>
25	<b>Task 25</b>	<b>As-Built Drawings</b>												
25.1	As-Built Drawings			5		10	20		40				75	\$11,358.45
	ODCs													
		Subtotals (Hours) =	N/A	5		10	20		40				75	\$11,358.45
		Subtotals (Costs) =		\$1,495.05		\$2,024.60	\$3,396.00		\$4,442.80				<b>75</b>	<b>\$11,358.45</b>
		<b>Totals (Summary) =</b>											<b>652</b>	<b>\$117,746.82</b>
		Total (Hours) = N/A		112		150	180		210				652	\$117,746.82
		Total (Costs) =		\$33,489.12		\$30,369.00	\$30,564.00		\$23,324.70				<b>652</b>	<b>\$117,746.82</b>
		Percentage of Total (Hours) = N/A		17%		23%	28%		32%				652	\$117,746.82
		Percentage of Total (Costs) =		28%		26%	26%		20%				652	117,746.82

## Work Order Estimate Summary

Att.C, AI 14, 04/25/24

Consultant/ Subconsultant:

Contract No:

Task Order No.

Work Order Title:

Attachment:

ODC Item	Description	Unit	Unit Cost	TASKS/WBS (1-5)										
				Task 20		Task 21		Task 22		Task 24		Task 25		
				Quantity	Total	Quantity	Total	Quantity	Total	Quantity	Total	Quantity	Total	
1														
2														
3														
4														
5														
6														
7														
8														
9														
10														
				Subtotal =	<input type="text"/>	Subtotal =	<input type="text"/>	Subtotal =	<input type="text"/>	Subtotal =	<input type="text"/>	Subtotal =	<input type="text"/>	

ODC Item	Description	TASKS/WBS (6-10)										Totals		
		Quantity	Total	Quantity	Total	Quantity	Total	Quantity	Total	Quantity	Total	Quantity	Total	
1														
2														
3														
4														
5														
6														
7														
8														
9														
10														
		Subtotal =	<input type="text"/>	Subtotal =	<input type="text"/>	Subtotal =	<input type="text"/>	Subtotal =	<input type="text"/>	Subtotal =	<input type="text"/>	Totals =	<input type="text"/>	



**Metropolitan  
Transit  
System**

**DRAFT FOR EXECUTIVE COMMITTEE REVIEW DATE: 4/11/2024**

## **Agenda Item No. 15**

MEETING OF THE SAN DIEGO METROPOLITAN TRANSIT SYSTEM  
BOARD OF DIRECTORS

April 25, 2024

**SUBJECT:**

Iris Rapid Transit Center East and Bus Stops Construction Management (CM) Services - Award Work Order Agreement

**RECOMMENDATION:**

That the San Diego Metropolitan Transit System (MTS) Board of Directors authorize the Chief Executive Officer (CEO) to execute Work Order No. WOA2498-CM19 under MTS Doc. No. G2498.0-21 (in substantially the same format as Attachment A), with Kleinfelder Construction Services, Inc. (KCS), totaling \$900,510.13 for CM services for the Iris Rapid Project.

Budget Impact

The total contract cost of this Work Order is estimated to be \$900,510.13 (Attachment A). The project will be funded by the Capital Improvement Program (CIP) account 1009113001– Iris Rapid – Route & Stations Infrastructure and CIP account 1006114201 -Iris Rapid Transit Center East Island Modification.

**DISCUSSION:**

The design for the Iris Rapid Transit Center East and Bus Stops has been completed and the construction of phase 2 of the project is in process, with an anticipated contract award date of April 2024 (Refer to Agenda Item (AI) 13). This recommended Work Order contract will provide CM services to augment MTS staff oversight of the construction contractor. The project involves modifications to Iris Rapid Transit Center East bus bay, bus stop upgrades including shelters, benches, and Variable Message Signs (VMS), and a new traffic signal at 30<sup>th</sup> and Coronado to improve bus route efficiency.

MTS requires CM services to assist staff with the coordination, control, and oversight of the construction contractor from beginning of the work through completion. The proposed Work Order for CM services includes resident engineering, field inspection, office engineering, project scheduling analysis, geotechnical testing and observations, hazardous materials testing, and quality assurance (QA) source and field inspections.



Construction Management (CM) Consultant Selection Process

On January 11, 2021, the San Diego Association of Governments (SANDAG) and MTS issued a joint Request for Statement of Qualifications (RFSQ) for On-Call CM Services. The RFSQ resulted in the identification of six (6) firms qualified to perform CM services (one of the qualified firms did not execute an agreement with MTS, leaving an on-call bench five firms); the MTS Board of Directors approved this panel of On-Call CM Services firms on July 29, 2021 (AI 16). Tasks are assigned to the firms through a work order process.

On January 19, 2024, MTS requested proposals from the firms on the On-Call List to provide CM Services for the Project.

On February 13., 2024, received a proposal from one CM firm, Kleinfelder Construction Services, Inc. (KCS). Four other firms chose not to propose. On March 1, 2024, MTS issued a post-proposal survey to attempt to ascertain why the other on-call firms did not provide proposals for the project. MTS did not receive any responses to this request. Thus, and after reviewing the scope of services, MTS staff determined that the solicitation, as issued, did not contain language that would have restricted participation, and proceeded with evaluation of the single proposal from KCS.

On March 5, 2024, MTS evaluated the proposal based on the required criteria, KCS was chosen as the highest qualified.

Ranking	Proposer Name	Total Score
1	KCS	93.33

For this project KCS will utilize the following subconsultants:

Subconsultant Name	Certification	Subconsultant Amount
CA Wehsener Engineering	Small Business Enterprise (SBE)	\$97,823.63
TRC Engineers	None	\$84,864.74
ZT Consulting Group Inc.	SBE	\$41,298.99

KCS' initial proposed amount for the services was \$934,347.85. Through negotiations, staff was able to reduce this amount by \$33,837.72. Based on the level of effort and proposed classifications, KCS' final cost proposal in the amount of \$900,510.13 was determined to be fair and reasonable.

Therefore, staff recommends that the MTS Board authorize the CEO to execute Work Order No. WOA2498-CM19 under MTS Doc. No. G2498.0-21 (in substantially the same format as Attachment A), with KCS, totaling \$900,510.13 for CM services for the Iris Rapid Project.

/s/ Sharon Cooney  
Sharon Cooney  
Chief Executive Officer

Key Staff Contact: Julia Tuer, 619.557.4515, [Julia.Tuer@sdmts.com](mailto:Julia.Tuer@sdmts.com)

Attachment: A. Draft Work Order Agreement WOA2498-CM19



# Metropolitan Transit System

April 25, 2024

MTS Doc. No. G2498.0-21  
Work Order No. WOA2498-CM19

Marc McIntyre  
Project/Task Order Manager  
Kleinfelder Construction Services, Inc.  
5761 Copley Drive Ste.100  
San Diego, CA 92101

Dear Mr. McIntyre:

Subject: WOA2498-CM19 TO MTS DOC. NO. G2498.0-21, CONSTRUCTION MANAGEMENT (CM) SERVICES WORK ORDER AGREEMENT FOR IRIS RAPID TRANSIT CENTER EAST AND BUS STOPS PROJECT

This letter shall serve as our agreement WOA2498-CM19 to MTS Doc. No. G2498.0-21, for Construction Management services under the Construction Management Consultant Agreement, as further described below.

## SCOPE OF SERVICES

Provide construction management services for the Iris Rapid Transit Center East and Bus Stops project, in accordance with Scope of Services (Attachment A and A1).

## SCHEDULE

The Schedule shall follow contract PWB380.0-24, Iris Rapid Transit Center East and Bus Stops Construction with Hazard Construction Engineering, LLC which is for a period of three hundred (300) calendar days from the issuance of the Notice to Proceed to the construction contractor. Inclusive of this schedule, acknowledging the construction project may experience delays/extensions, the period of performance of this work order shall be for three hundred sixty (360) days.

## PAYMENT

Payment shall be based on actual costs in the amount of \$900,510.13. Payment shall not be exceeded without prior written authorization of MTS.





Please sign below, and return the document to the Contracts Specialist at MTS. All other terms and conditions shall remain the same and in effect.

Sincerely,

Accepted:

---

Sharon Cooney  
Chief Executive Officer

Mark McIntyre, Project/Task Order Manager  
Kleinfelder Construction Services, Inc.

Date:

Attachments: Attachment A, Scope of Services  
Attachment A1, Consultant's Proposal  
Attachment B, Negotiated Fee Proposal

DRAFT

ATTACHMENT A  
SCOPE OF SERVICES

DRAFT

**TITLE:** Iris Rapid Bus Stops and Transit Center East **WOA #:** WOAXXXX-CM19  
Construction Management (CM) Services

## **I. PROJECT DESCRIPTION**

This project entails the completion of a new 'Rapid' Bus Route between the Otay Mesa Transit Center, the Iris Transit Center and the Imperial Communities. Work encompasses new bus stops and shelters, visual messaging system (VMS) signs and pedestals, and associated appurtenances (Exhibit A, Construction Documents).

## **II. SCOPE OF WORK**

The scope of work shall consist of the following tasks and deliverables:

### **TASK 1.0 Project/Work Order Manager**

Tasks include:

- 1.1 Manage CM contract budget and schedule
- 1.2 Verify that the assigned field personnel are trained in the skills that are needed to manage each task
- 1.3 Administer personnel action, coordinate personnel matters with MTS' Contract Manager
- 1.4 Review monthly invoices prior to submission to MTS

### **TASK 2.0 Construction Management and Inspection Services**

- 2.1 Consultant shall oversee and monitor construction activities performed by the contractor per project plans and specifications, including periodic job site safety reviews.
  - 2.1.1 Resident Engineering
    - 2.1.1.1 Attend preconstruction meeting and construction set-up
    - 2.1.1.2 Coordinate Request for Information (RFI) and submittal log coordination between the contractor and designer
    - 2.1.1.3 Inspect, document, and review Contract Change Orders (CCOs)
    - 2.1.1.4 Attend weekly progress meetings
    - 2.1.1.5 Provide Quality Assurance (QA) inspection oversight
    - 2.1.1.6 Provide post construction, project close-out
  - 2.1.2 Field Inspection services for the following construction disciplines:
    - 2.1.2.1 Civil
    - 2.1.2.2 Electrical
    - 2.1.2.3 Landscape
    - 2.1.2.4 Stormwater Compliance
    - 2.1.2.5 Environmental Health and Safety
      - 2.1.2.5.1 California Air Resource Board (CARB) In Use Off Road Diesel Fueled Fleet Regulations
  - 2.1.3 Office Engineering
  - 2.1.4 Project scheduling analysis
  - 2.1.5 Stormwater Permit Compliance Reporting
  - 2.1.6 Geotechnical testing and observation services
    - 2.1.6.1 Compaction testing of subgrade, aggregate base, and footing bottoms
    - 2.1.6.2 Asphalt concrete compaction
    - 2.1.6.3 Soil and aggregate laboratory testing
    - 2.1.6.4 Reinforced concrete inspection and sampling (plus sample pickup)

- 2.1.7 QA source inspection services
  - 2.1.7.1 Steel fabrication audit
  - 2.1.7.2 Welding submittal reviews (shop drawings, welding quality control plan)
  - 2.1.7.3 QA Certified Welding Inspections (CWI) – startup
  - 2.1.7.4 QA CWI/ Nondestructive Testing (NDT) inspections (intermittent)
- 2.1.8 QA Field Inspection Services
  - 2.1.8.1 Field welding submittal reviews (welding Quality Control Plan)
  - 2.1.8.2 Field post-installed anchors

**Staffing:**

1. Resident Engineer
2. Assistant Resident Engineer/Office Engineer
3. Field Inspectors -Civil, Electrical, Landscape
4. QA Inspectors
5. Scheduler
6. Stormwater Compliance Specialist
7. Materials Testers/Engineers

**III. PERIOD OF PERFORMANCE**

The period of performance shall be three hundred sixty (360) calendar days from the date of the Notice to Proceed.

**IV. DELIVERABLES**

Deliverables will consist of the daily work products produced under direct supervision by MTS management which include:

1. Inspector’s daily reports and photographs
2. Residents Engineers’ daily or weekly status reports and updates.
3. A set of 24x36 size prints of the project marked on the front “RESIDENT ENGINEER COPY”
4. Correspondence files.
5. Geotechnical and Materials Testing Reports
6. Request for Information (RFIs) and Submittal Logs
7. Meeting Minutes
8. Contract Change Order Documentation
9. Project Closeout and Final Records Transmittal .

**V. SCHEDULE OF SERVICES/MILESTONES/DELIVERABLES**

**A. Tasks Schedule**

<b>Task</b>	<b>Begin/End Dates</b>
1.0 Project/Work Order Management	NTP plus 300 Calendar Days
2.0 Construction Management and Inspection Services	
Project Closeout and Final Records Transmittal	NTP plus 300 Calendar Days

**B. Milestones/Deliverables Schedule**

<b>Milestone/Deliverable</b>	<b>Due Date</b>
------------------------------	-----------------

1. Inspector's Daily Reports and Photographs	NTP plus 300 Calendar Days
2. Resident Engineer's daily or weekly status reports and updates.	NTP plus 300 Calendar Days
3. A set of 24x36 size prints of the project marked on the front "RESIDENT ENGINEER COPY" for as-built record keeping	NTP plus 300 Calendar Days
4. Correspondence Files	NTP plus 300 Calendar Days
5. Geotechnical and Materials Testing Reports	NTP plus 300 Calendar Days
6. RFI and Submittal Logs	NTP plus 300 Calendar Days
7. Meeting Minutes	NTP plus 300 Calendar Days
8. CCO Documentation	NTP plus 300 Calendar Days
9. Project Closeout and Final Records Transmittal	NTP plus 300 Calendar Days

**VI. MATERIALS TO BE PROVIDED BY MTS AND/OR THE OTHER AGENCY**

1. Project drawings, specifications, and other pertinent project documents.
2. Necessary forms for project flaggers.
3. Flagging personnel for work alongside the MTS right-of-way.
4. MTS Roadway Worker training (if not current, and at the Consultant's expense) for personnel to be working on the project, at all sites, alongside the MTS right-of-way.
5. Access to all signal and highway grade crossing facilities as required.

**VII. SPECIAL CONDITIONS**

Any condition listed below applies solely to this Work Order and does not otherwise alter the Agreement or other Work Orders.

Not Applicable.

**VIII. MTS ACCEPTANCE OF SERVICES:**

Contractor shall not be compensated at any time for unauthorized work outside of this Work Order. Contractor shall provide notice to MTS' Project Manager upon 100% completion of this Work Order. Within five (5) business days from receipt of notice of Work Order completion, MTS' Project Manager shall review, for acceptance, the 100% completion notice. If Contractor provides final service(s) or final work product(s) which are found to be unacceptable due to Contractors and/or Contractors subcontractors negligence and thus not 100% complete by MTS' Project Manager, Contractor shall be required to make revisions to said service(s) and/or work product(s) within the Not to Exceed (NTE) Budget. MTS reserves the right to withhold payment associated with this Work Order until the Project Manager provides written acceptance for the 100% final completion notice. Moreover, 100% acceptance and final completion will be based on resolution of comments received to the draft documents and delivery of final documentation which shall incorporate all MTS revisions and comments.

Monthly progress payments shall be based on hours performed for each person/classification identified in the attached Fee Schedule and shall at no time exceed the NTE. Contractor shall only be compensated for actual performance of services and at no time shall be compensated for services for which MTS does not have an accepted deliverable or written proof and MTS acceptance of services performed.

**IX. DEFICIENT WORK PRODUCT**

Throughout the construction management and/or implementation phases associated with the services rendered by the Contractor, if MTS finds any work product provided by Contractor to be deficient and the deficiently delays any portion of the project, Contractor shall bear the full burden of their deficient work and shall be responsible for taking all corrective actions to remedy their deficient work product including but not limited to the following:

- Paying applicable delay fees,
- Revising provided documents,

At no time will MTS be required to correct any portion of the Contractors deficient work product and shall bear no costs or burden associated with Contractors deficient performance and/or work product.

#### **X. DELIVERABLE REQUIREMENTS**

Contractor will be required to submit any and all documentation required by the Scope of Work. The deliverables furnished shall be of a quality acceptable to MTS. The criteria for acceptance shall be a product of neat appearance, well-organized, and procedurally, technically and grammatically correct. MTS reserves the right to request a change in the format if it doesn't satisfy MTS's needs. All work products will become the property of MTS. MTS reserves the right to disclose any reports or material provided by the Contractor to any third party.

Contractor shall provide with each task, a work plan showing the deliverables schedule as well as other relevant date needed for Contractor's work control, when and as requested by MTS.

Contractor's computer data processing and work processing capabilities and data storage should be compatible with Windows compatible PC's, text files readable in Microsoft Word, and standard and customary electronic storage. Contractor shall maintain backup copies of all data conveyed to MTS.

Contractor shall provide MTS with hard copy or electronic versions of reports and/or other material as requested by MTS.

#### **XI. PRICING**

MTS shall reimburse the Contractor for actual costs of Work Order Agreements (including labor costs, employee benefits, overhead, and other direct costs applicable to the specific Work Order Agreement) incurred by the Contractor in performance of the work, in an amount established in the Work Order Agreement (WOA). Actual costs shall not exceed the estimated wage rates established in the negotiations between the Parties.

Fees and all other charges will be billed as identified in the WOA, and the net amount shall be due at the time of billing, unless otherwise specified.

#### **XII. ADDITIONAL INFORMATION**

List additional information as applicable to the specific Work Order scope of services.

- QA source and specialty inspections based on single fabricator local within Southern California.

- QA source and specialty inspections based on an adequate Contractor quality control fabrication, testing and inspection program. If determined necessary and agreed upon by MTS, QA inspections may be increased.
- Contract time may be extended by weather or unforeseen delays that arise during construction. Costs may need to be re-visited should this occur.
- Assume South Bay Maintenance Facility (SBMF) and Iris Rapid Projects run concurrently.

**XIII. PREVAILING WAGE**

Prevailing wage rates apply to certain personnel for these services?  Yes  No

Exhibits: A, Construction Documents

DRAFT

**EXHIBIT A  
CONSTRUCTION DOCUMENTS**

DRAFT



GENERAL NOTES :

- 1. APPROVAL OF THESE PLANS BY THE CITY ENGINEER DOES NOT AUTHORIZE ANY WORK TO BE PERFORMED UNTIL A PERMIT HAS BEEN ISSUED.
2. UPON ISSUANCE OF A PERMIT, NO WORK WILL BE PERMITTED ON WEEKENDS OR HOLIDAYS UNLESS APPROVED BY TRAFFIC CONTROL PERMIT FROM THE DEVELOPMENT SERVICES DEPARTMENT.
3. THE APPROVAL OF THIS PLAN OR ISSUANCE OF A PERMIT BY THE CITY OF SAN DIEGO DOES NOT AUTHORIZE THE PERMIT HOLDER OR OWNER TO VIOLATE ANY FEDERAL, STATE OR CITY LAWS, ORDINANCES, REGULATIONS, OR POLICIES.
4. IMPORTANT NOTICE: SECTION 4216 OF THE GOVERNMENT CODE REQUIRES A DIG ALERT IDENTIFICATION NUMBER ISSUED BEFORE A "PERMIT TO EXCAVATE" WILL BE VALID. FOR YOUR DIG ALERT I.D. NUMBER, CALL UNDERGROUND SERVICE ALERT, TOLL FREE (800) 422-4133, TWO DAYS BEFORE YOU DIG.
5. CONTRACTOR SHALL BE RESPONSIBLE FOR POTHOLING AND LOCATING ALL EXISTING UTILITIES THAT CROSS THE PROPOSED TRENCH LINE WHILE MAINTAINING A 1 FOOT VERTICAL CLEARANCE.
6. "PUBLIC IMPROVEMENT SUBJECT TO DESUETUDE OR DAMAGE." IF REPAIR OR REPLACEMENT OF SUCH PUBLIC IMPROVEMENTS IS REQUIRED, CONTRACTOR SHALL OBTAIN THE REQUIRED PERMITS FOR WORK IN THE PUBLIC RIGHT-OF-WAY, SATISFACTORY TO THE PERMIT ISSUING AUTHORITY.
7. DEVIATIONS FROM THESE SIGNED PLANS WILL NOT BE ALLOWED UNLESS A CONSTRUCTION CHANGE IS APPROVED BY THE CITY ENGINEER OR THE CHANGE IS REQUIRED BY THE RESIDENT ENGINEER.
8. CONTRACTOR SHALL REPLACE OR REPAIR ALL TRAFFIC SIGNAL LOOPS, CONDUITS, AND LANE STRIPING DAMAGED DURING CONSTRUCTION.
9. PRIOR TO SITE DISTURBANCE, CONTRACTOR SHALL MAKE ARRANGEMENTS FOR A PRECONSTRUCTION MEETING WITH THE CITY OF SAN DIEGO, CONSTRUCTION MANAGEMENT AND FIELD SERVICES DIVISION (858) 627-3200.
10. CONTRACTOR SHALL ONLY PERFORM SITE SURVEY AND UTILITY MARK OUT SERVICES PRIOR TO THE PRECONSTRUCTION MEETING.
11. CONTRACTOR SHALL IMPLEMENT AN EROSION CONTROL PROGRAM DURING THE PROJECT CONSTRUCTION ACTIVITIES. THE PROGRAM SHALL COMPLY WITH ALL APPLICABLE REQUIREMENTS OF THE STATE WATER RESOURCE CONTROL BOARD.
12. CONTRACTOR SHALL HAVE EMERGENCY MATERIAL AND EQUIPMENT ON HAND FOR UNFORESEEN SITUATIONS, SUCH AS DAMAGE TO UNDERGROUND WATER, SEWER, AND STORM DRAIN FACILITIES WHERE FLOW MAY GENERATE EROSION AND SEDIMENT POLLUTION.
13. "AS-BUILT" DRAWINGS MUST BE SUBMITTED TO THE RESIDENT ENGINEER PRIOR TO ACCEPTANCE OF THIS PROJECT BY THE CITY OF SAN DIEGO.
14. MANHOLES AND PULL BOX COVER SHALL BE LABELED WITH NAME OF COMPANY.
15. CONTRACTOR SHALL PROVIDE RED-LINES DRAWINGS IN ACCORDANCE WITH 2-5.4 OF THE WHITEBOOK, "RED-LINES AND RECORD DOCUMENTS."
16. CONTRACTOR SHALL MAINTAIN A MINIMUM OF 1 FOOT VERTICAL SEPARATION TO ALL UTILITIES UNLESS OTHERWISE SPECIFIED ON THE PLANS.
17. CONTRACTOR SHALL REMOVE AND REPLACE ALL UTILITY BOXES SERVING AS HANDHOLES THAT ARE NOT IN "AS-NEW" CONDITION IN PROPOSED SIDEWALK, DAMAGED BOXES, OR THOSE THAT ARE NOT IN COMPLIANCE WITH CURRENT CODE SHALL BE REMOVED AND REPLACED WITH NEW BOXES, INCLUDING WATER, SEWER, TRAFFIC SIGNALS, STREET LIGHTS, DRY UTILITIES-SDD&E, COX, ETC. ALL NEW METAL LIDS SHALL BE SLIP RESISTANT AND INSTALLED FLUSH WITH PROPOSED SIDEWALK GRADE. IF A SLIP RESISTANT METAL LID IS NOT COMMERCIALY AVAILABLE FOR THAT USE, NEW BOXES AND LIDS SHALL BE INSTALLED.
18. THE AREA WHICH IS DEFINED AS A NON GRADING AREA AND WHICH IS NOT TO BE DISTURBED SHALL BE STAKED PRIOR TO START OF THE WORK. THE PERMIT APPLICANT AND ALL OF THEIR REPRESENTATIVES OR CONTRACTORS SHALL COMPLY WITH THE REQUIREMENTS FOR PROTECTION OF THIS AREA AS REQUIRED BY ANY APPLICABLE AGENCY. ISSUANCE OF THE CITY'S GRADING PERMIT SHALL NOT RELIEVE THE APPLICANT OR ANY OF THEIR REPRESENTATIVES OR CONTRACTORS FROM COMPLYING WITH ANY STATE OR FEDERAL REQUIREMENTS BY AGENCIES INCLUDING BUT NOT LIMITED TO CALIFORNIA REGIONAL WATER QUALITY CONTROL BOARD, CALIFORNIA DEPARTMENT OF FISH AND GAME, COMPLIANCE MAY INCLUDE OBTAINING PERMITS, OTHER AUTHORIZATIONS, OR COMPLIANCE WITH MANDATES BY ANY APPLICABLE STATE OR FEDERAL AGENCY.
19. PRIOR TO CONSTRUCTION, SURVEY MONUMENTS (HORIZONTAL AND VERTICAL) THAT ARE LOCATED IN THE CONSTRUCTION AREA SHALL BE TIED-OUT AND REFERENCED BY A LAND SURVEYOR.
20. UPON COMPLETION OF CONSTRUCTION, ALL DESTROYED SURVEY MONUMENTS ARE REQUIRED TO BE REPLACED, AND A CORNER RECORD OR RECORD OF SURVEY SHALL BE PREPARED AND FILED WITH THE COUNTY SURVEYOR AS REQUIRED BY THE PROFESSIONAL LAND SURVEYOR ACT, SECTION 8771 OF THE BUSINESS AND PROFESSIONS CODE OF THE STATE OF CALIFORNIA.

MONUMENT PRESERVATION CERTIFICATION:

THE PERMITTEE SHALL BE RESPONSIBLE FOR THE COST OF REPLACING ALL SURVEY MONUMENTS DESTROYED BY CONSTRUCTION. IF A VERTICAL CONTROL MONUMENT IS TO BE DISTURBED OR DESTROYED, THE CITY OF SAN DIEGO FIELD SURVEY SECTION SHALL BE NOTIFIED IN WRITING AT LEAST 7 DAYS PRIOR TO DEMOLITION/CONSTRUCTION.

- THE TYPE OF CONSTRUCTION WILL NOT AFFECT ANY SURVEY MONUMENTS (THIS LINE IS FOR PROJECTS THAT ARE PROPOSING NO DEMOLITION, TRENCHING, ASSOCIATED WITH A CIP, ETC)

DATE

PRIOR TO PERMIT ISSUANCE, THE PERMITTEE SHALL RETAIN THE SERVICE OF A PROFESSIONAL LAND SURVEYOR OR CIVIL ENGINEER AUTHORIZED TO PRACTICE LAND SURVEYING WHO WILL BE RESPONSIBLE FOR MONUMENT PRESERVATION AND SHALL PROVIDE A CORNER RECORD OR RECORD OF SURVEY TO THE COUNTY SURVEYOR AS REQUIRED BY THE PROFESSIONAL LAND SURVEYORS ACT, IF APPLICABLE. (SECTION 8771 OF THE BUSINESS AND PROFESSIONS CODE OF THE STATE OF CALIFORNIA)

I HAVE INSPECTED THE SITE AND DETERMINED THAT:

- NO SURVEY MONUMENTS WERE FOUND WITHIN THE LIMITS OF WORK
SURVEY MONUMENTS EXISTING IN OR NEAR LIMITS OF WORK WILL BE PROTECTED IN PLACE
SURVEY MONUMENTS HAVE BEEN TIED OUT AND A FINAL OR PARCEL MAP WILL BE FILED (NO CORNER RECORD OR RECORD OF SURVEY WILL BE REQUIRED)
OTHER AGENCY SURVEY MONUMENT (CORNER RECORD OR RECORD OF SURVEY MAY NOT BE REQUIRED). AGENCY HAS BEEN NOTIFIED OF POSSIBLE MONUMENT DESTRUCTION AND A LETTER PROVIDED TO CITY
A PRE-CONSTRUCTION CORNER RECORD (OR RECORD OF SURVEY) FOR SURVEY MONUMENTS FOUND WITHIN THE LIMITS OF WORK HAS BEEN FILED.

CORNER RECORDS: CR 47785, CR 47786, CR 47787 & CR 47788 OR RECORD OF SURVEY #

JOEL RIIPINEN P.L.S. NO. 7942 EXP. 12-13-23 DATE

POST CONSTRUCTION CORNER RECORD (AS-BUILT ITEM)

- POST CONSTRUCTION CORNER RECORD FOR SURVEY MONUMENTS DESTROYED DURING CONSTRUCTION AND REPLACED AFTER CONSTRUCTION.

CORNER RECORD # OR RECORD OF SURVEY #

DATE

IMPROVEMENT PLANS FOR: METROPOLITAN TRANSIT SYSTEM IRIS RAPID CORRIDOR AND STATION DESIGN

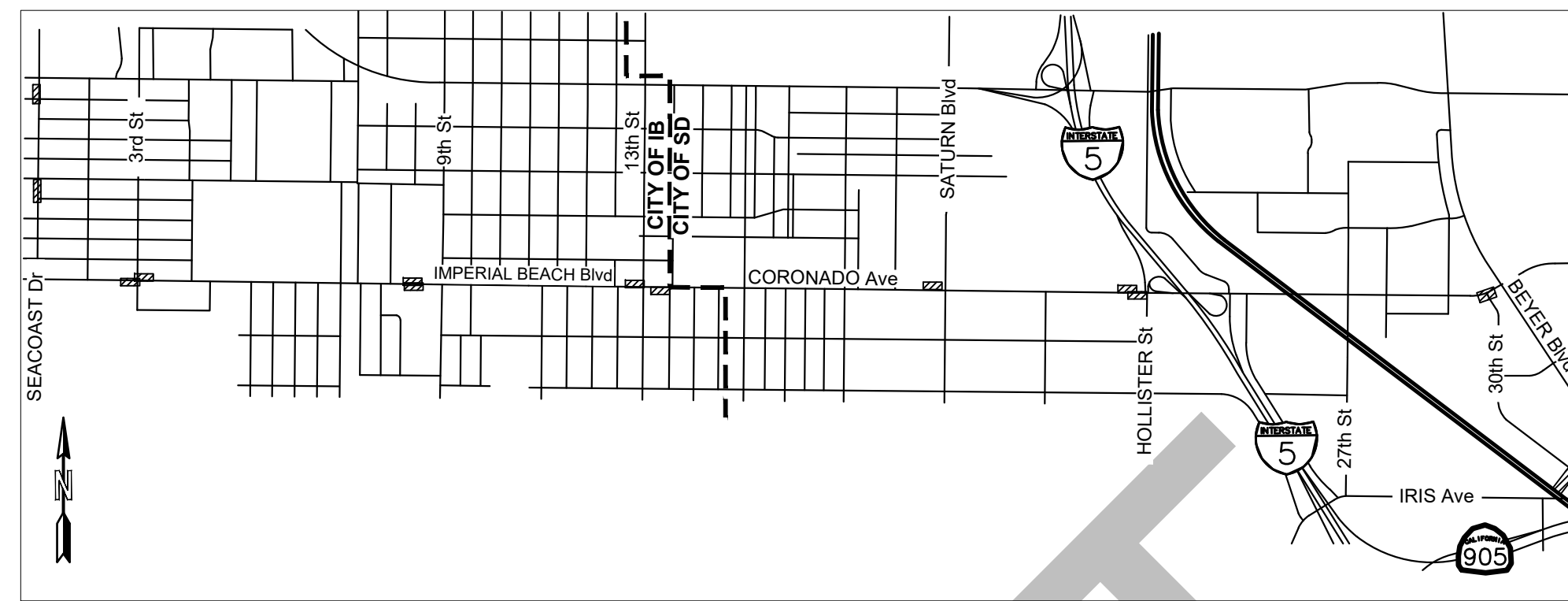

PROJECT SITE

VICINITY MAP NO SCALE

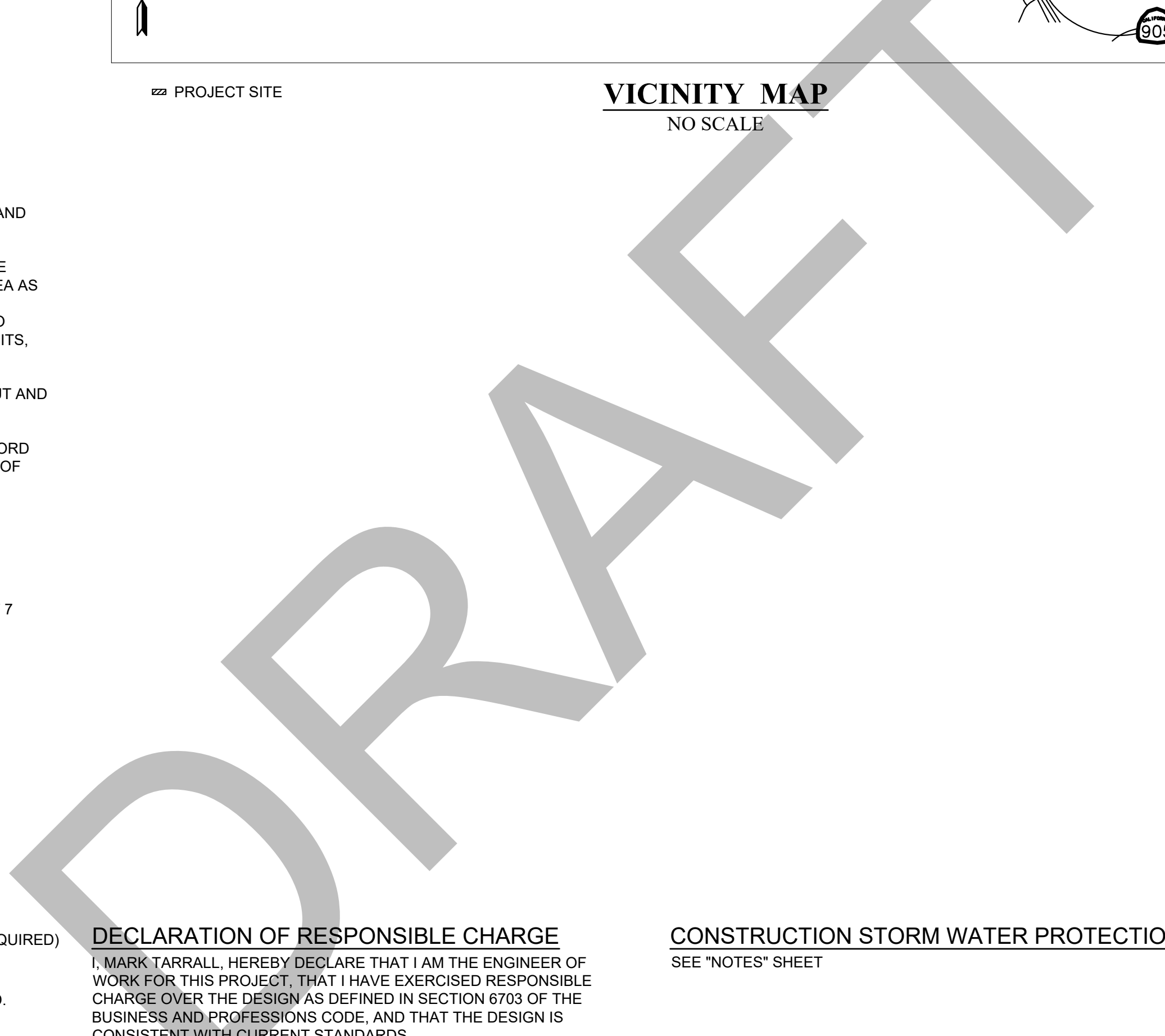

DECLARATION OF RESPONSIBLE CHARGE

I, MARK TARRALL, HEREBY DECLARE THAT I AM THE ENGINEER OF WORK FOR THIS PROJECT, THAT I HAVE EXERCISED RESPONSIBLE CHARGE OVER THE DESIGN AS DEFINED IN SECTION 6703 OF THE BUSINESS AND PROFESSIONS CODE, AND THAT THE DESIGN IS CONSISTENT WITH CURRENT STANDARDS.

I UNDERSTAND THAT THE CHECK OF PROJECT DRAWINGS AND SPECIFICATIONS BY THE CITY OF SAN DIEGO IS CONFINED TO REVIEW ONLY AND DOES NOT RELIEVE ME, AS ENGINEER OF WORK, OF MY RESPONSIBILITIES FOR PROJECT DESIGN.

SIGNED: [Signature] R.C.E. NO. 71953 EXP. ON 12-31-23

DATE: 3/17/23



CONSTRUCTION STORM WATER PROTECTION NOTES:

SEE "NOTES" SHEET

WORK TO BE DONE:

THE PUBLIC IMPROVEMENTS SHOWN ON THESE PLANS SHALL BE CONSTRUCTED ACCORDING TO THE FOLLOWING STANDARD SPECIFICATIONS AND STANDARD DRAWINGS.

STANDARD SPECIFICATIONS:

Table with 2 columns: DOCUMENT NO. and DESCRIPTION. Lists various specification documents like PWP1010119-01, PWP1010119-02, etc.

STANDARD DRAWINGS:

Table with 2 columns: DOCUMENT NO. and DESCRIPTION. Lists standard drawing documents like PWP1010119-03, PWP1010119-06, etc.

FOR LEGEND:

SEE "NOTES" SHEET

REFERENCE DRAWINGS:

Table with 2 columns: DRAWING TITLE and SHEET NO. Lists reference drawings like STREET IMPROVEMENT PLANS FOR EVERGREEN AND SEACOAST (2010), etc.

SHEET INDEX

Table with 2 columns: DESCRIPTION and SHEET NO. Lists sheet contents like TITLE SHEET, NOTES, KEYMAP, etc.

AGENCY SHEET INDEX

Table with 3 columns: AGENCY, APPLICABLE SHEETS, and SHEET NO. Lists agency sheets from City of San Diego and City of Imperial Beach.

SITE ADDRESS:

CITY OF IMPERIAL BEACH: ALONG SEACOAST DRIVE FROM DAHLIA AVE TO EVERGREEN AVE AND ALONG IMPERIAL BEACH BLVD FROM 3RD AVE TO 13TH ST
CITY OF SAN DIEGO: ALONG CORONADO AVE FROM 13 ST TO BEYER BLVD AND IRIS AVENUE TRANSIT CENTER

OWNER/APPLICANT:

APPLICANT: ELIAS BELKNAP (MTS)
ADDRESS: 1255 IMPERIAL AVE, SUITE 1000, SAN DIEGO, CA, 92101
PHONE NUMBER: 619-316-1998

TOPOGRAPHY SOURCE:

AGUIRRE & ASSOCIATES
863 CENTER DRIVE, SUITE 5A, LA MESA, CA 91942
TOPO SOURCE METHOD:
PERFORMED IN SEPTEMBER, 2020

BASIS OF BEARINGS:

THE BASIS OF BEARINGS FOR THIS PLAN SET IS THE CALIFORNIA COORDINATE SYSTEM, CCS83, ZONE 6, EPOCH 1991.35 AND IS DETERMINED BY G.P.S. MEASUREMENTS TAKEN ON SEPT. 4, 2020 AND WERE ESTABLISHED FROM G.P.S. STATION 190 PER ROS 14492 AND G.P.S. STATION 56 PER ROS 17055.

THE BEARING FROM G.P.S. STATION 190 TO G.P.S. STATION 56 IS N 69°33'33" W.

THE COMBINED GRID FACTOR AT G.P.S. POINT 190 IS 1.0000436.

GRID DISTANCE = GROUND DISTANCE X COMBINED GRID FACTOR.

NGVD 29 ELEVATION AT G.P.S. POINT 190 IS 141.66'

THE CONVERGENCE ANGLE AT G.P.S. STATION 190 IS -00°26'08.26".

BENCHMARK: (NAVD88)

ELEVATIONS SHOWN HEREON ARE IN TERMS OF THE NORTH AMERICAN VERTICAL DATUM OF 1988 (NAVD88) BASED LOCALLY UPON THE FOLLOWING CITY OF SAN DIEGO BENCHMARK CONVERTED TO NAVD 88 BY THE NGS VERTCON PROGRAM.

BENCHMARK:

BP NW COR CORONADO AVE & OUTER RD. ELEVATION: 38.91 (36.79' NGVD 29 + 2.12')

ENGINEERING PERMIT NO.:

DISCRETIONARY PERMIT NO.:

PRIVATE CONTRACT

TITLE SHEET FOR: IRIS RAPID CORRIDOR AND STATION DESIGN
IMPERIAL BEACH BLVD/CORONADO AVE AND IRIS AVE AT HOWARD AVE

CITY OF SAN DIEGO, CALIFORNIA
DEVELOPMENT SERVICES DEPARTMENT
SHEET 1 OF 42 SHEETS
PROJECT NO. XXXXX

Table with 4 columns: FOR CITY ENGINEER, DATE, V.T.M., and other tracking information. Includes rows for AS-BUILTS, CONTRACTOR, and INSPECTOR.

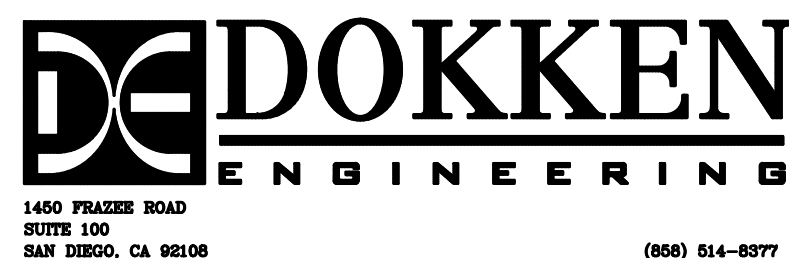

CONSTRUCTION CHANGE TABLE

Table with 5 columns: CHANGE, DATE, EFFECTED OR ADDED SHEET NUMBERS, APPROVAL NO., PROJECT NO.

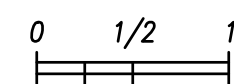

IF THIS BAR DOES NOT MEASURE 1" THEN DRAWING IS NOT TO SCALE.

The City of SAN DIEGO DEVELOPMENT SERVICES DEPARTMENT

CITY OF IMPERIAL BEACH
DEPARTMENT OF DEVELOPMENT SERVICES (SHEETS 1-12, 24, 25, 27, 34-39, 42-45 ONLY)
DATE

AS-BUILT
SIGNATURE RCE NUMBER DATE

STREET DATA TABLE

Table with 5 columns: STREET NAME, CLASSIFICATION, SPEED (MPH), ADT (VEHICLES), R/W (FT). Lists streets like CORONADO AVENUE, IRIS AVENUE, BEYER BOULEVARD.

ABBREVIATIONS:

Table with 4 columns: ABBREV, ABBREVIATION, GPM, GALLONS PER MINUTE. Lists various materials and construction terms like AC, ALUM, ASTM, AWG, BMP, BOSW, C&G, CAB, CP, CTB, DIAM, DG, EG, EL, Exist, FG, FL, FND, FS, FT, GAL, GB, GL.

CONSTRUCTION BMP GENERAL NOTES:

PRIOR TO ANY SOIL DISTURBANCE, TEMPORARY EROSION AND SEDIMENT CONTROL SHALL BE INSTALLED BY THE CONTRACTOR OR QUALIFIED PERSON(S) AS INDICATED BELOW:

- 1. ALL REQUIREMENTS OF THE CITY OF SAN DIEGO 'LAND DEVELOPMENT MANUAL, STORM WATER STANDARDS' MUST BE INCORPORATED INTO THE DESIGN AND CONSTRUCTION OF THE PROPOSED GRADING/IMPROVEMENTS...
2. THE CONTRACTOR SHALL INSTALL AND MAINTAIN ALL STORM DRAIN INLETS...
3. ALL CONSTRUCTION BMPS SHALL BE IN PLACE AT THE END OF EACH WORKING DAY WHEN RAIN IS IMMINENT.

CURB RAMP NOTE:

THE REQUIRED DETECTABLE WARNING (TRUNCATED DOMES) ON CURB RAMPS ARE TO COMPLY WITH THE CITY STANDARDS (SDG-130) AND SPECIFICATIONS. A 12" X 12" (MIN.) SAMPLE OF THE DETECTABLE WARNING, THE PRODUCTS' TEST REPORT AND A COPY OF THE MANUFACTURER'S INSTALLATION INSTRUCTION MUST BE SUBMITTED TO THE DESIGNATED CITY RESIDENT ENGINEER FOR REVIEW PRIOR TO INSTALLATION.

TRAFFIC CONTROL NOTE:

- 1. VALIDATION: THE TRAFFIC CONTROL PLAN IS NOT VALID UNTIL WORK DATES AND WORK HOURS ARE APPROVED. THE CONTRACTOR SHALL SUBMIT TWO (2) REDUCED COPIES OF TRAFFIC CONTROL PLANS (11"X17") TO THE TRAFFIC CONTROL PERMIT COUNTER...
2. CONTRACTOR SHALL NOTIFY THE CITY TRAFFIC ENGINEER AT (858) 465-4742 A MINIMUM OF FIVE (5) WORKING DAYS PRIOR TO ANY CONSTRUCTION WORK AFFECTING TRAFFIC SIGNALS.

Table with 3 columns: DESCRIPTION, EDITION, DOCUMENT NO. Lists references like STANDARD SPECIFICATIONS FOR PUBLIC WORKS CONSTRUCTION (GREENBOOK), 2021 EDITION.

- 4. NOTIFICATIONS: THE CONTRACTOR SHALL NOTIFY THE FOLLOWING AGENCIES A MINIMUM OF FIVE (5) WORKING DAYS PRIOR TO ANY EXCAVATION, CONSTRUCTION, OR TRAFFIC CONTROL AFFECTING THE AGENCIES LISTED BELOW: FIRE DEPARTMENT DISPATCH, POLICE DEPARTMENT DISPATCH, ENVIRONMENTAL SERVICES, STREET DIVISION, METROPOLITAN TRANSIT SYSTEM (MTS), TAXI ZONES, TROLLEY LINES, (ANY EXCAVATION), (32ND ST NAVAL STATION).

THE CONTRACTOR SHALL NOTIFY PROPERTY OWNERS AND TENANTS A MINIMUM OF FIVE (5) WORKING DAYS PRIOR TO CLOSURE OF DRIVEWAYS/ THE CONTRACTOR SHALL POST SIGNS NOTIFYING THE PUBLIC A MINIMUM OF FIVE (5) WORKING DAYS PRIOR TO CLOSURE OF STREETS.

- 5. POSTING PARKING RESTRICTIONS: THE CONTRACTOR SHALL POST TOW-AWAY/NO PARKING SIGNS SEVENTY-TWO (72) HOURS IN ADVANCE OF PARKING REMOVAL. SIGNS SHALL INDICATE SPECIFIC DATES, DATES AND TIMES OF RESTRICTION. PARKING METERS SHALL BE BAGGED WHERE APPLICABLE.

6. EXCAVATIONS: EXCEPT WHEN OTHERWISE SHOWN ON THE PLANS, ALL TRENCHES SHALL BE BACKFILLED OR TRENCH-PLATED AT THE END OF EACH WORKDAY. AN ASPHALT RAMP SHALL BE PLACED AROUND EACH TRENCH PLATE TO PREVENT THE PLATE FROM BEING DISLODGED. CONTRACTOR SHALL MONITOR TRENCH PLATES DURING NON-WORKING HOURS TO ENSURE THAT THEY DO NOT BECOME DISLODGED.

7. COVERED PEDESTRIAN WALKWAY: THE CONTRACTOR SHALL CONTACT CITY RESIDENT ENGINEER AT (619) 627-3200 FOR INSPECTION OF ANY COVERED PEDESTRIAN WALKWAY DURING CONSTRUCTION OF SUCH WALKWAY.

8. RESTORATION OF ROADWAY: THE CONTRACTOR SHALL REPAIR OR REPLACE ALL EXISTING IMPROVEMENTS WITHIN THE RIGHT-OF-WAY NON DESIGNATED FOR PERMANENT REMOVAL (TRAFFIC SIGNS, STRIPING, PAVEMENT MARKERS, PAVEMENT MARKINGS, LEGENDS, CURB MARKINGS, LOOP DETECTORS, TRAFFIC SIGNAL EQUIPMENT, ETC.) WHICH ARE DAMAGED OR REMOVED AS A RESULT OF OPERATIONS.

9. PROVISION OF TEMPORARY TRAFFIC SIGNAL DETECTION: THE CONTRACTOR SHALL INSTALL CITY APPROVED TEMPORARY VIDEO OR RADAR DETECTION WHEN EXISTING TRAFFIC SIGNAL DETECTION SYSTEMS ARE DAMAGED, DISABLED, OR BECOME INEFFECTIVE DUE TO CONSTRUCTION ACTIVITIES FOR A PERIOD OF FIVE (5) OR MORE DAYS.

10. CHANGE IN WORK: THE CITY ENGINEER RESERVES THE RIGHT TO OBSERVE THESE TRAFFIC CONTROL PLANS IN OPERATION AND TO MAKE ANY CHANGES AS FIELD CONDITIONS WARRANT. ANY CHANGES SHALL BE DOCUMENTED AND SUPERSEDE THESE PLANS.

CONSTRUCTION STORM WATER PROTECTION NOTES:

- 1. TOTAL SITE DISTURBANCE AREA (ACRES): <1 ACRE WATERSHED: TIJUANA RIVER-FRONTAL PACIFIC OCEAN / OTAY RIVER HYDRAULIC SUB AREA NAME AND NUMBER: SAN YSIDRO 911.11 / POGGI CANYON 910.20
2. THE PROJECT SHALL COMPLY WITH THE REQUIREMENTS OF THE MWPCP THE PROJECT IS SUBJECT TO MUNICIPAL STORM WATER PERMIT NUMBER R9-2013-0001 AND SUBSEQUENT AMENDMENTS.

LEGEND: PROPOSED IMPROVEMENTS

Table with 3 columns: IMPROVEMENT, STANDARD DWGS, SYMBOL. Lists items like 6" CURB, CONCRETE SIDEWALK, CURB RAMP, AC BUS STOP PAD, CONCRETE BUS STOP SLAB, TYPE A GRAVITY WALL (PVT), PROPOSED(RE)LOCATED SIGN, PROPOSED PERMANENT MTS EASEMENT LIMITS, PROPOSED TEMPORARY CONSTRUCTION EASEMENT (TCE), SAWCUT LINE / IMPROVEMENT LIMITS, LIMITS OF GRADING, BUS SHELTER & BUS SHELTER FOUNDATION FOOTPRINT (PVT), VMS SIGN (PVT), TYPE A PED BARRICADE (PVT WHERE NOTED), 4-FT TALL CHAIN LINK FENCE (PVT).

EXISTING IMPROVEMENTS

Table with 2 columns: EXISTING IMPROVEMENTS, SYMBOL. Lists items like EXISTING SIGN, EXISTING MASONRY, EXISTING BUS PAD, EXISTING RIGHT OF WAY LINE, EXISTING PROPERTY LINE, INDICATES SURVEY MONUMENT, AS NOTED, TO BE DESTROYED DURING AND REPLACED AFTER CONSTRUCTION, INDICATES SURVEY MONUMENT, AS NOTED, TO BE PROTECTED IN PLACE, EXISTING CURB AND GUTTER, EXISTING CONCRETE BUS PAD.

- 6. THE CONTRACTOR OR QUALIFIED PERSON SHALL BE RESPONSIBLE FOR CLEANUP OF ALL SILT, DEBRIS AND MUD ON AFFECTED AND ADJACENT STREET(S) AND WITHIN STORM DRAIN SYSTEM DUE TO CONSTRUCTION VEHICLES/EQUIPMENT AND CONSTRUCTION ACTIVITY AT THE END OF EACH WORK DAY.
7. THE CONTRACTOR SHALL PROTECT NEW AND EXISTING STORM WATER CONVEYANCE SYSTEMS FROM SEDIMENTATION, CONCRETE RINSE, OR OTHER CONSTRUCTION RELATED DEBRIS AND DISCHARGES WITH THE APPROPRIATE BMPS THAT ARE ACCEPTABLE TO THE ENGINEER AND AS INDICATED IN THE SWPPP/MWPCP.
8. THE CONTRACTOR OR QUALIFIED PERSON SHALL CLEAR DEBRIS, SILT AND MUD FROM ALL DITCHES AND SWALES PRIOR TO AND AFTER EACH RAIN EVENT.



MARK TARRALL R.C.E. NO. 71953 EXP. 12-31-23

DOKKEN ENGINEERING 1450 FRAZEE ROAD, SUITE 100 (858) 514-8377

Table 1: MINIMUM REQUIRED STANDARD CONSTRUCTION STORMWATER BMPs. Lists various BMPs like Vegetation Stabilization Planting, Hydraulic Stabilization Hydroseeding, Bonded Fiber Matrix or Stabilized Fiber Matrix (Winter), Physical Stabilization Erosion Control Blanket (Winter), Lot Perimeter Protection Detail, Mulch, Straw, Woodchips, Soil Application, Energy Dissipater Outlet Protection, Silt Fence, Fiber Rolls (Straw Wattles), Gravel Bags, Dewatering Filtration, Storm Drain Inlet Protection, Stabilized Construction Entrance, Entrance/Exit Tire Wash, Street Sweeping & Vacuuming, Material Delivery & Storage, Spill Prevention & Control, Concrete Waste Management, Solid Waste Management, Sanitary Waste Management, Hazardous Waste Management.

NOTES FOR IRIS RAPID CORRIDOR AND STATION DESIGN IMPERIAL BEACH BLVD/CORONADO AVE. CITY OF SAN DIEGO, CALIFORNIA DEVELOPMENT SERVICES DEPARTMENT SHEET 2 OF 42 SHEETS. PROJECT NO. XXXXXX. V.T.M. 1786-6299 NAD83 COORDINATES 146-1739 LAMBERT COORDINATES. CONTRACTOR DATE STARTED INSPECTOR DATE COMPLETED. XXXXX-02-D

**TRUCK HAUL NOTES:**

THE CONTRACTOR SHALL SUBMIT A TRUCK HAUL ROUTE PLAN (11"x17") FOR APPROVAL PRIOR TO STARTING EXPORT OR IMPORT OF MATERIAL. THE PLAN SHOULD BE SUBMITTED TO THE TRAFFIC CONTROL PERMIT COUNTER, 3RD FLOOR, BOOTH 22, ENGINEERING DIVISION, DEVELOPMENT SERVICES CENTER, 1222 FIRST AVENUE, SAN DIEGO (619) 446-5150. CONTRACTOR SHALL OBTAIN A TRAFFIC CONTROL PERMIT A MINIMUM OF FIVE (5) WORKING DAYS PRIOR TO STARTING WORK.

**PRIVATE NOTE:**

ALL ONSITE, PRIVATE IMPROVEMENTS SHOWN ON THIS DRAWING ARE FOR INFORMATION ONLY. THE CITY ENGINEER'S APPROVAL OF THIS DRAWING, IN NO WAY CONSTITUTES AN APPROVAL OF SAID PRIVATE IMPROVEMENTS. A SEPARATE PERMIT FOR SUCH IMPROVEMENTS MAY BE REQUIRED.

**EMRA NOTE:**  
ALL MTS BUS SHELTERS AND VMS POLES/SIGNS PROPOSED WITHIN CITY OF SAN DIEGO PUBLIC RIGHT-OF-WAY ARE COVERED UNDER EMRA APPROVAL #2593913.

**NOTE:**  
THESE DIMENSIONS ARE TYPICAL AND MAY BE DIFFERENT AT LOCATIONS THAT HAVE ADDITIONAL SITE CONSTRAINTS OR ADDITIONAL ROOM FOR WIDER WALKWAYS. SEE PLANS FOR ANY ATYPICAL DIMENSIONS.

AGREEMENT DATA			
APPROVAL TYPE	DESCRIPTION	APPROVAL NO.	SEE SHEET NUMBER(S)
EMRA	AGREEMENT TO ALLOW FOR ENCROACHMENT OF MTS PRIVATE IMPROVEMENTS WITHIN CITY OF SAN DIEGO PUBLIC RIGHT-OF-WAY BY INSTALLING & MAINTAINING PRIVATE IMPROVEMENTS THAT INCLUDE BUS SHELTERS, BUS SIGNS, VMS POLES/SIGNS, CONCRETE PAVEMENT, CURB, GUTTER, SIDEWALKS, PEDESTRIAN BARRICADES, TRANSIT FACILITY SIGNS, AND STRIPING.	2593913	3, 13-14, 36

STREET NAME	STATION LIMITS	AS-BUILT PAVEMENT STRUCTURAL SECTION		
		AC (IN.)	CTB (IN.)	PCC (IN.)

**NOTE:**  
STREET SUBGRADE SOIL SAMPLES ARE TO BE TAKEN FOR "R" VALUE ANALYSIS BY A PRIVATE GEOTECHNICAL ENGINEERING FIRM AND UNDER THE DIRECTION OF THE RESIDENT ENGINEER. THESE ANALYSIS ARE TO BE PERFORMED BY A CERTIFIED PRIVATE GEOTECHNICAL FIRM TO DETERMINE THE PAVEMENT SECTION(S) DURING CONSTRUCTION. A PAVEMENT SECTION LETTER WILL BE ISSUED BY THE CITY.

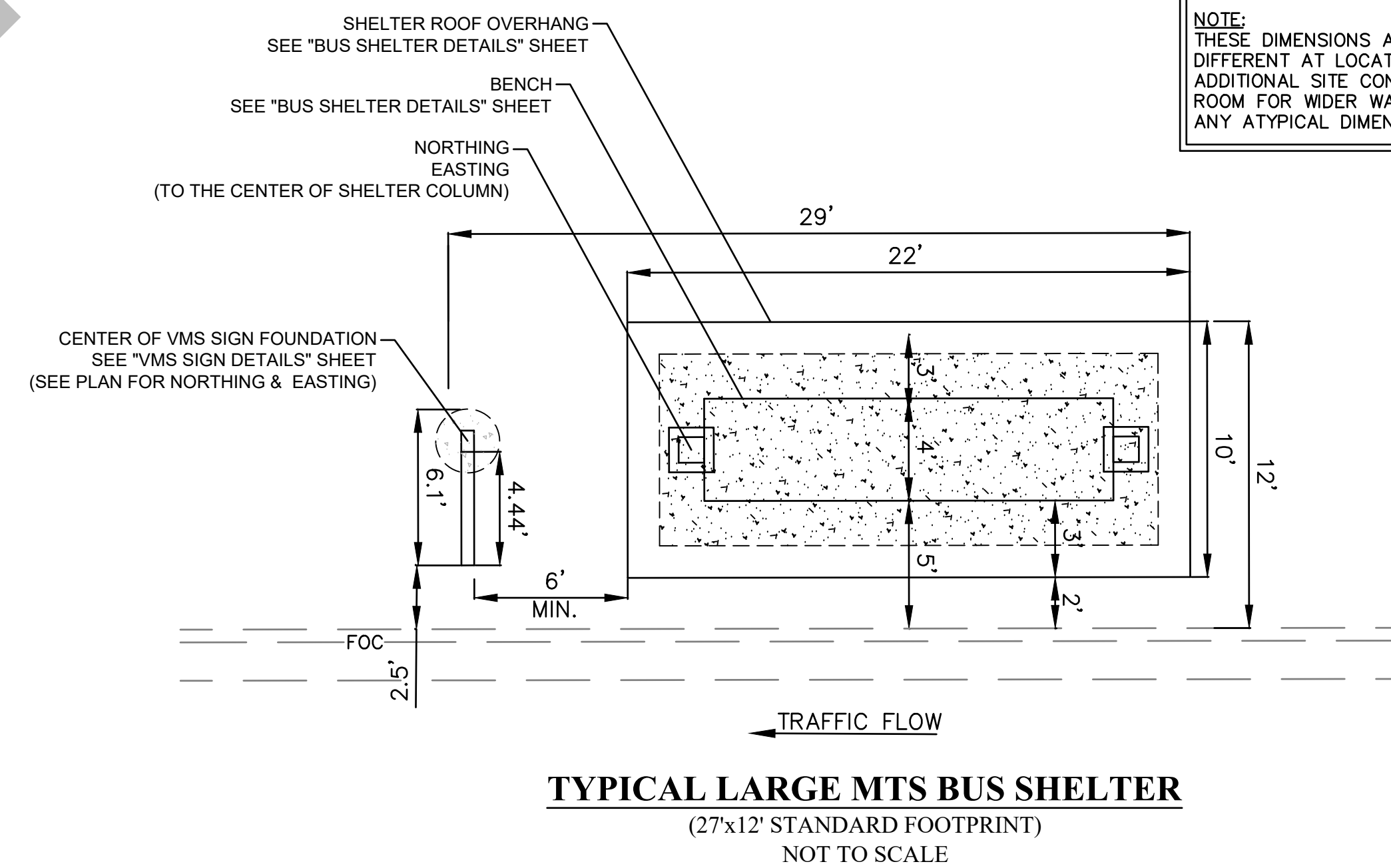
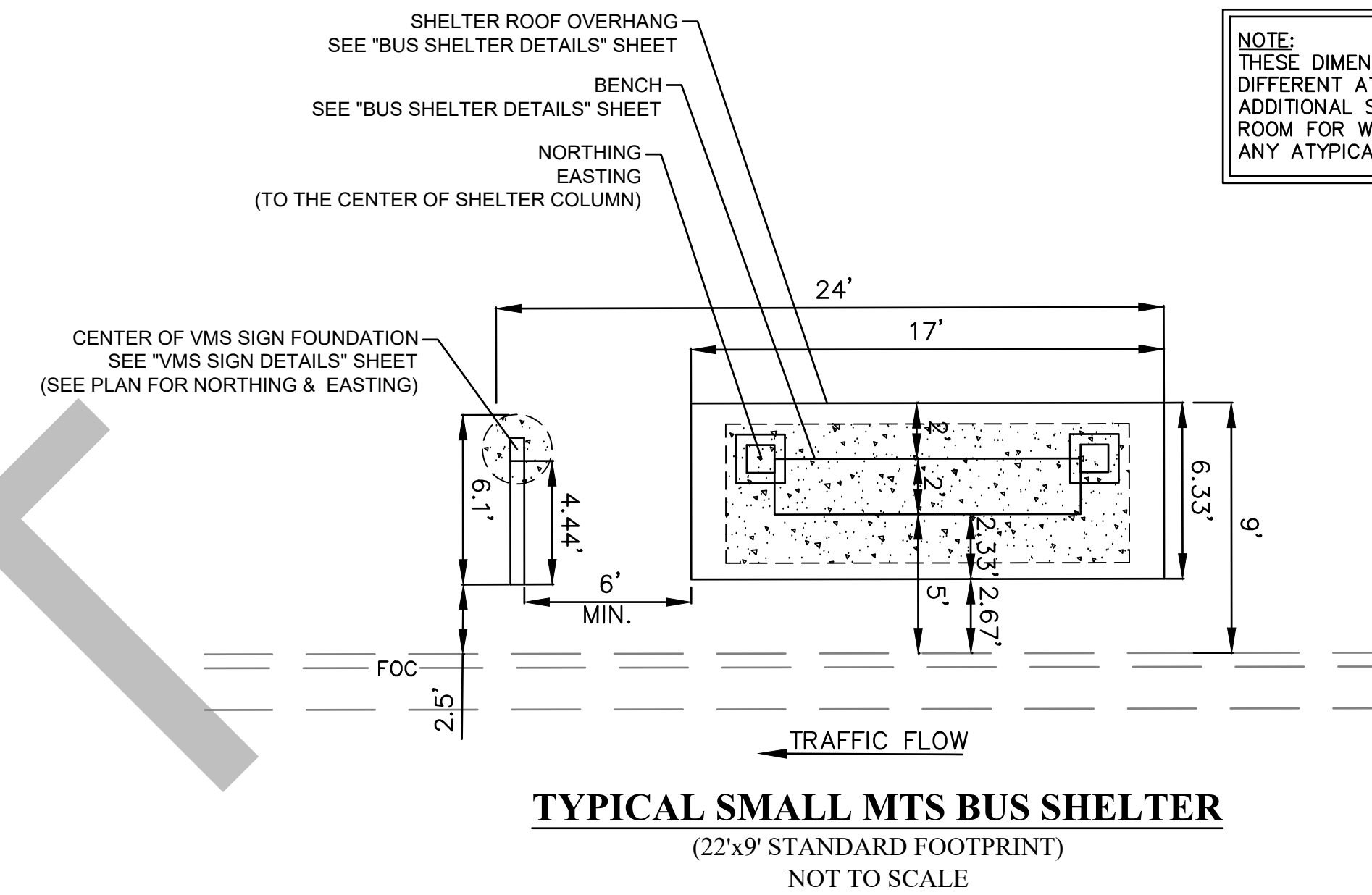

**NOTE:**  
THESE DIMENSIONS ARE TYPICAL AND MAY BE DIFFERENT AT LOCATIONS THAT HAVE ADDITIONAL SITE CONSTRAINTS OR ADDITIONAL ROOM FOR WIDER WALKWAYS. SEE PLANS FOR ANY ATYPICAL DIMENSIONS.

DRAFT

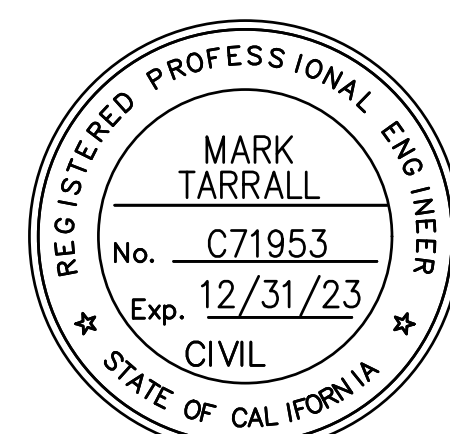

*Mark Tarrall*  
MARK TARRALL R.C.E. NO. 71953 EXP. 12-31-23

DOKKEN ENGINEERING  
1450 FRAZEE ROAD, SUITE 100  
(858) 514-8377

DATE

PRIVATE CONTRACT

**NOTES FOR:**  
**IRIS RAPID CORRIDOR AND STATION DESIGN**  
IMPERIAL BEACH BLVD/CORONADO AVE

CITY OF SAN DIEGO, CALIFORNIA DEVELOPMENT SERVICES DEPARTMENT SHEET 9 OF 42 SHEETS		PROJECT NO. XXXXXX
FOR CITY ENGINEER	DATE	V.T.M.
DESCRIPTION	BY	APPROVED
AS-BUILTS		
CONTRACTOR	DATE STARTED	
INSPECTOR	DATE COMPLETED	

1786-6299  
NAD83 COORDINATES  
146-1739  
LAMBERT COORDINATES  
**XXXXX-03-D**

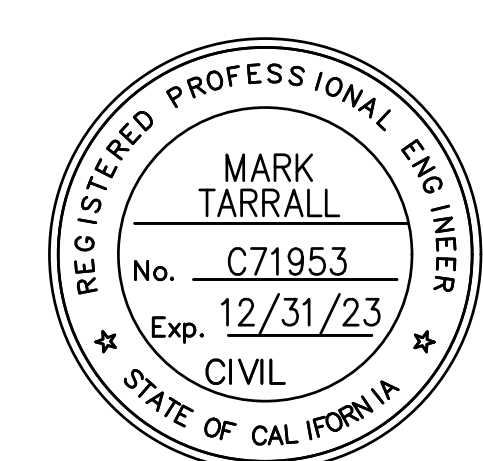
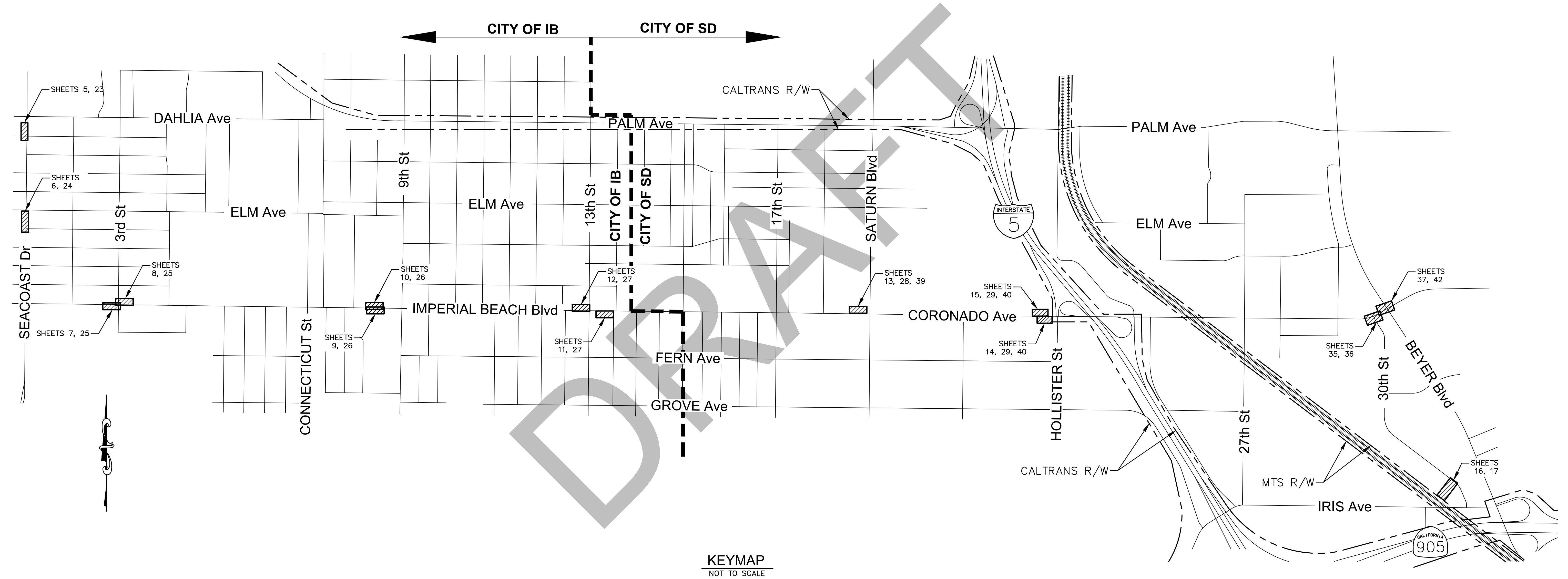

*Mark Tarrall*  
 MARK TARRALL      R.C.E. NO. 71953      EXP. 12-31-23

DOKKEN ENGINEERING  
 1450 FRAZEE ROAD, SUITE 100  
 (858) 514-8377

DATE \_\_\_\_\_

PRIVATE CONTRACT

**KEYMAP FOR:**  
**IRIS RAPID CORRIDOR AND STATION DESIGN**  
 IMPERIAL BEACH BLVD/CORONADO AVE

CITY OF SAN DIEGO, CALIFORNIA DEVELOPMENT SERVICES DEPARTMENT SHEET 4 OF 42 SHEETS		PROJECT NO. XXXXXX
FOR CITY ENGINEER	DATE	V.T.M.
DESCRIPTION	BY	APPROVED
		DATE
		FILMED
		1786-6299
		NAD83 COORDINATES
		146-1739
		LAMBERT COORDINATES
AS-BUILTS		
CONTRACTOR	DATE STARTED	
INSPECTOR	DATE COMPLETED	

**XXXXX-04-D**

**LEGEND:**

- AC BUS PAD  
(SEE DETAIL A, THIS SHEET)
- BUS SHELTER THIN SLAB  
FOUNDATION FOOTPRINT

**NOTES:**

1. SEE SHEET 3 FOR TYPICAL BUS SHELTER DIMENSIONS AND MINIMUM CLEARANCES (UNLESS OTHERWISE NOTED).
2. ALL ROADWAY STRIPING AFFECTED BY BUS PAD INSTALLATION SHALL BE REPLACED IN KIND.
3. COORDINATE EXISTING STREET FURNITURE REMOVAL (BY OTHERS) WITH MTS.

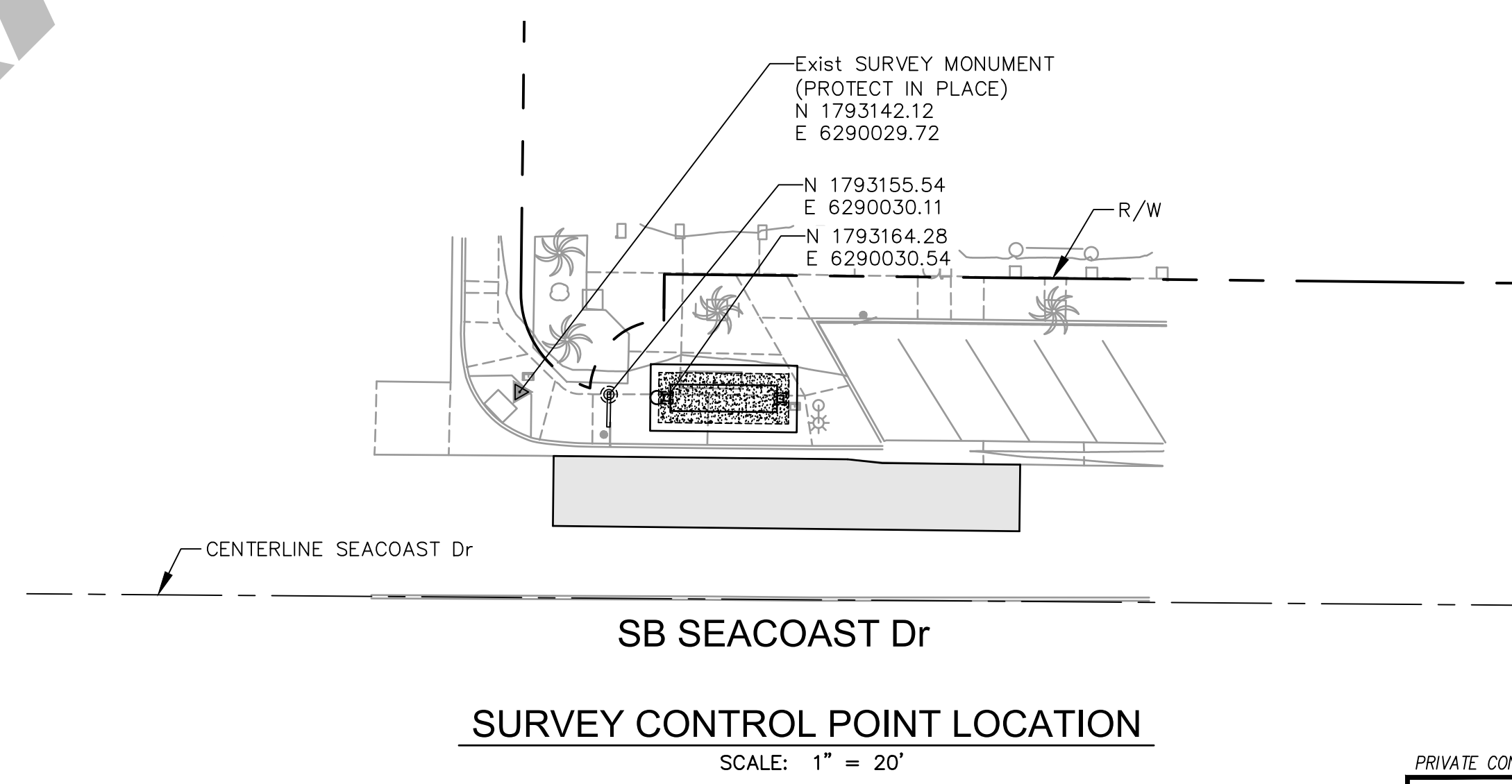
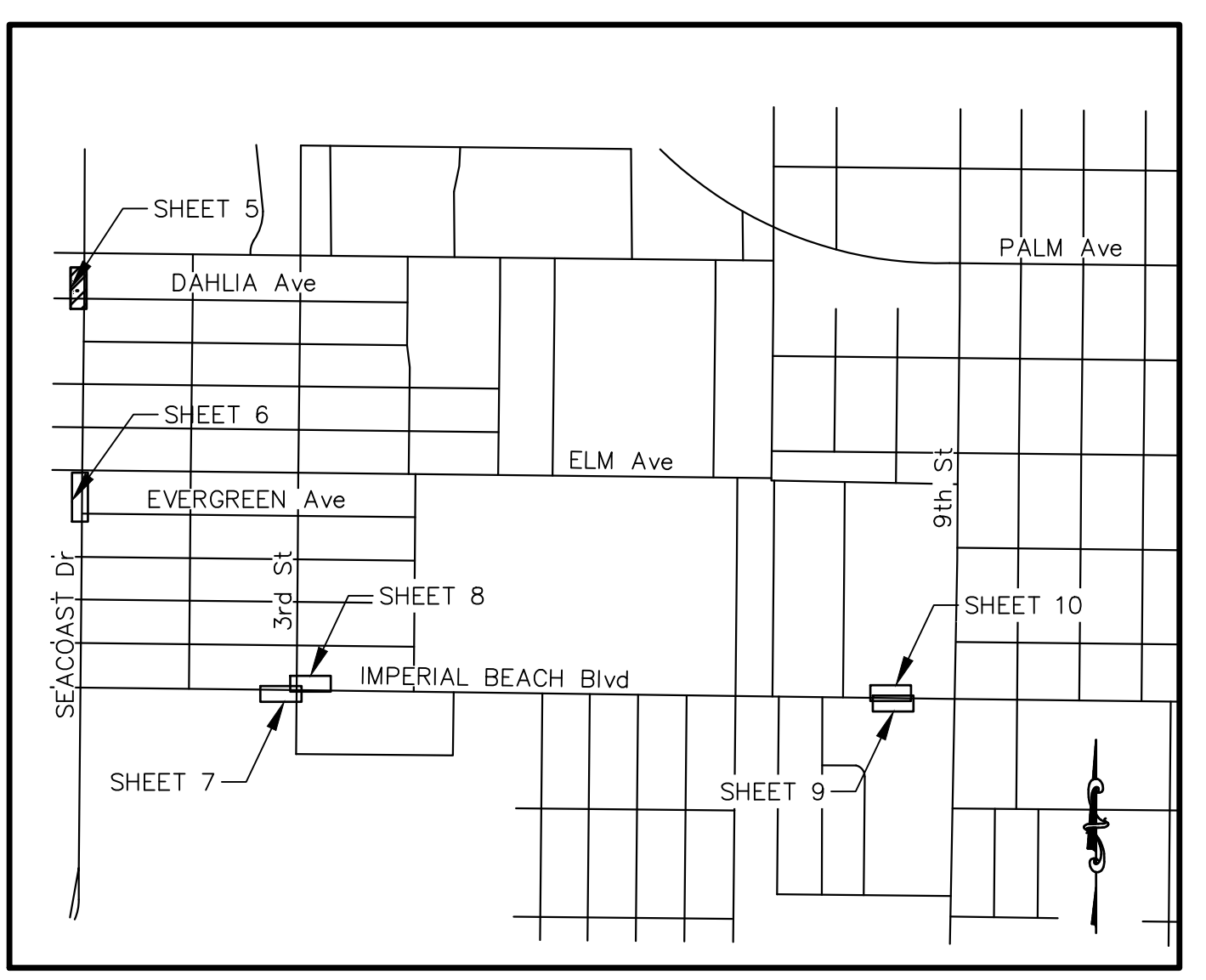
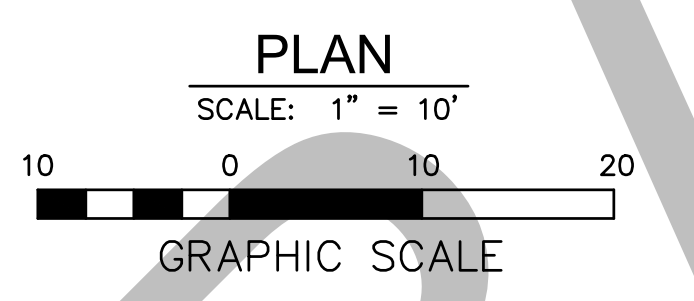
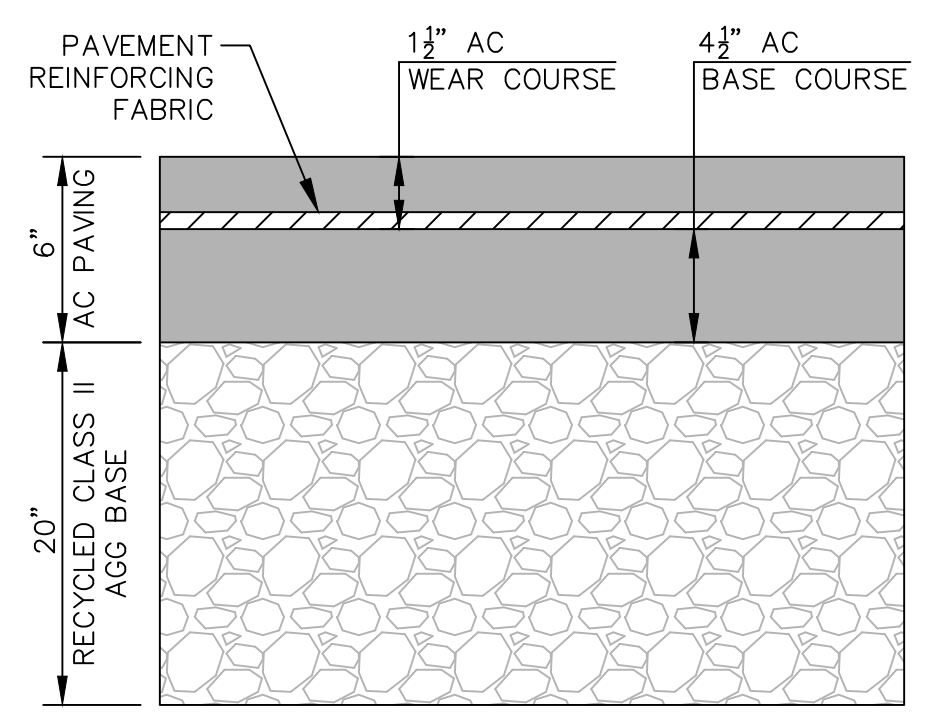
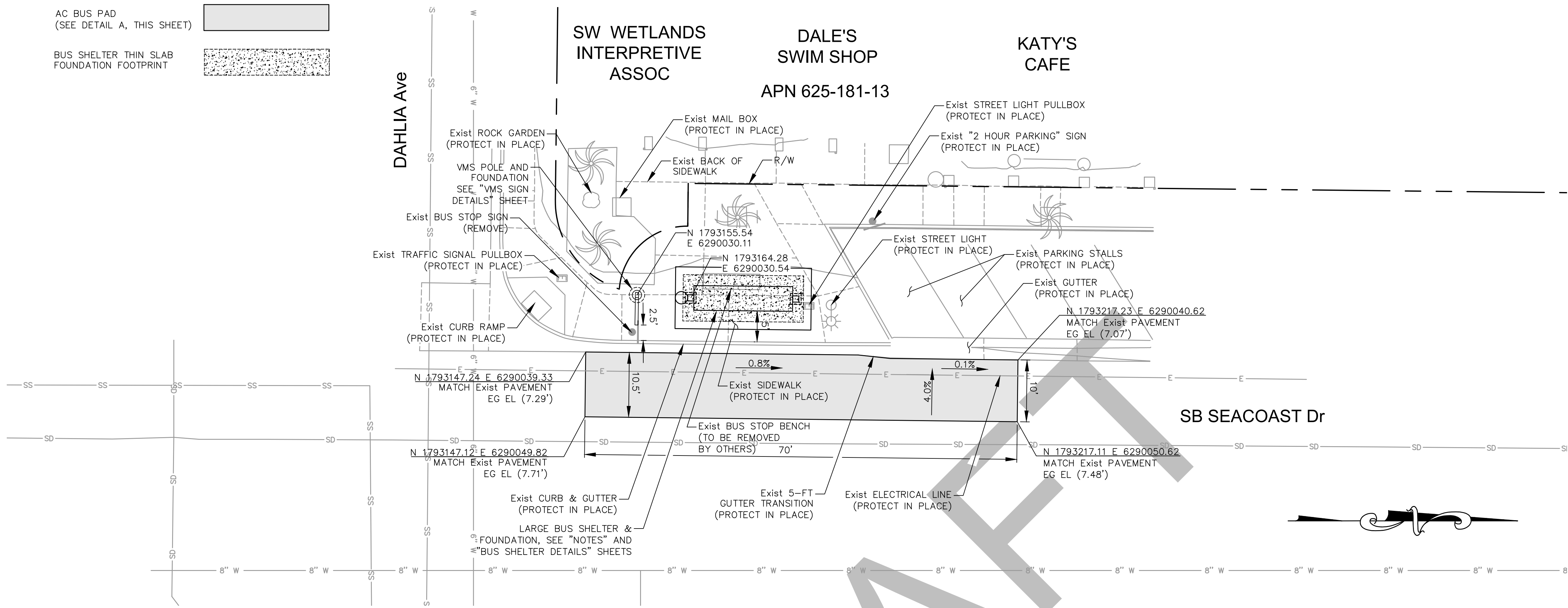

*Mark Tarrall*  
 MARK TARRALL R.C.E. NO. 71953 EXP. 12-31-23

DOKKEN ENGINEERING  
 1450 FRAZEE ROAD, SUITE 100  
 (858) 514-8377

**NOTE:**  
 THE CITY OF SAN DIEGO ENGINEER DOES NOT CONSTITUTE APPROVAL OF THIS SHEET AS IT ONLY REFLECTS IMPROVEMENTS LOCATED WITHIN CITY OF IMPERIAL BEACH JURISDICTION.

PRIVATE CONTRACT			
<b>IMPROVEMENT PLANS FOR IRIS RAPID CORRIDOR AND STATION DESIGN</b> IMPERIAL BEACH BLVD/CORONADO AVE			
CITY OF IMPERIAL BEACH, CALIFORNIA		PROJECT NO. XXXXXX	
SHEET 5 OF 42 SHEETS		V.T.M.	
DESCRIPTION	BY	APPROVED	DATE FILMED
AS-BUILTS			
CONTRACTOR	DATE STARTED		
INSPECTOR	DATE COMPLETED		
		1786-6299	NAD83 COORDINATES
		146-1739	LAMBERT COORDINATES
		<b>05-D</b>	

**LEGEND:**

AC BUS PAD  
(SEE DETAIL A, THIS SHEET)



BUS SHELTER THIN SLAB  
FOUNDATION FOOTPRINT

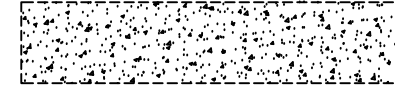

**NOTES:**

1. SEE SHEET 3 FOR TYPICAL BUS SHELTER DIMENSIONS AND MINIMUM CLEARANCES (UNLESS OTHERWISE NOTED).
2. ALL ROADWAY STRIPING AFFECTED BY BUS PAD INSTALLATION SHALL BE REPLACED IN KIND.
3. COORDINATE EXISTING LOCAL BUS SHELTER REMOVAL (BY OTHERS) WITH MTS.

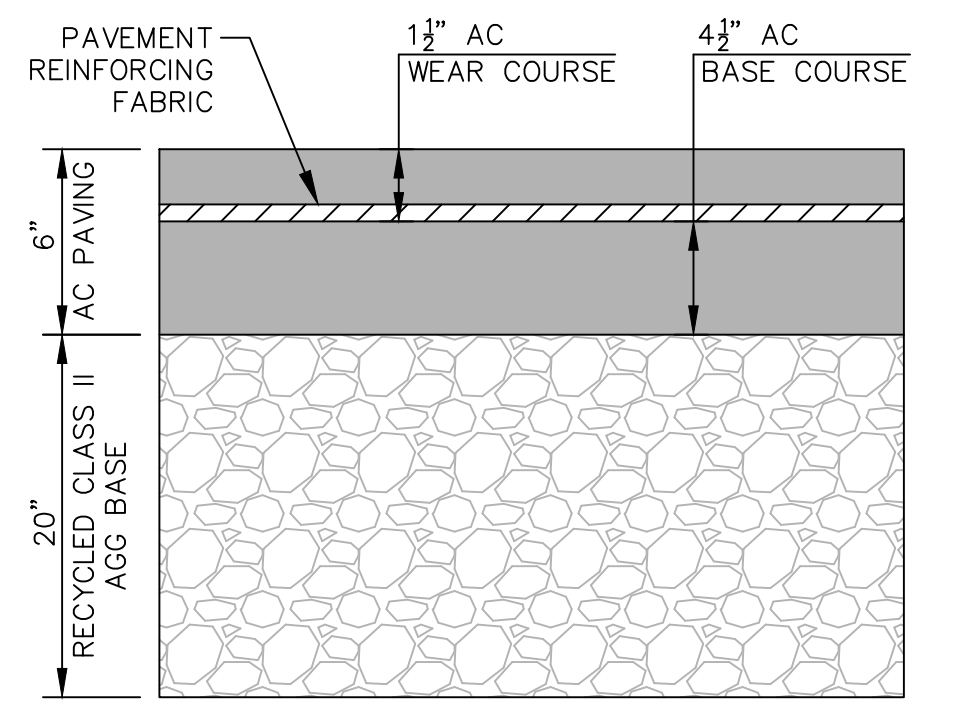
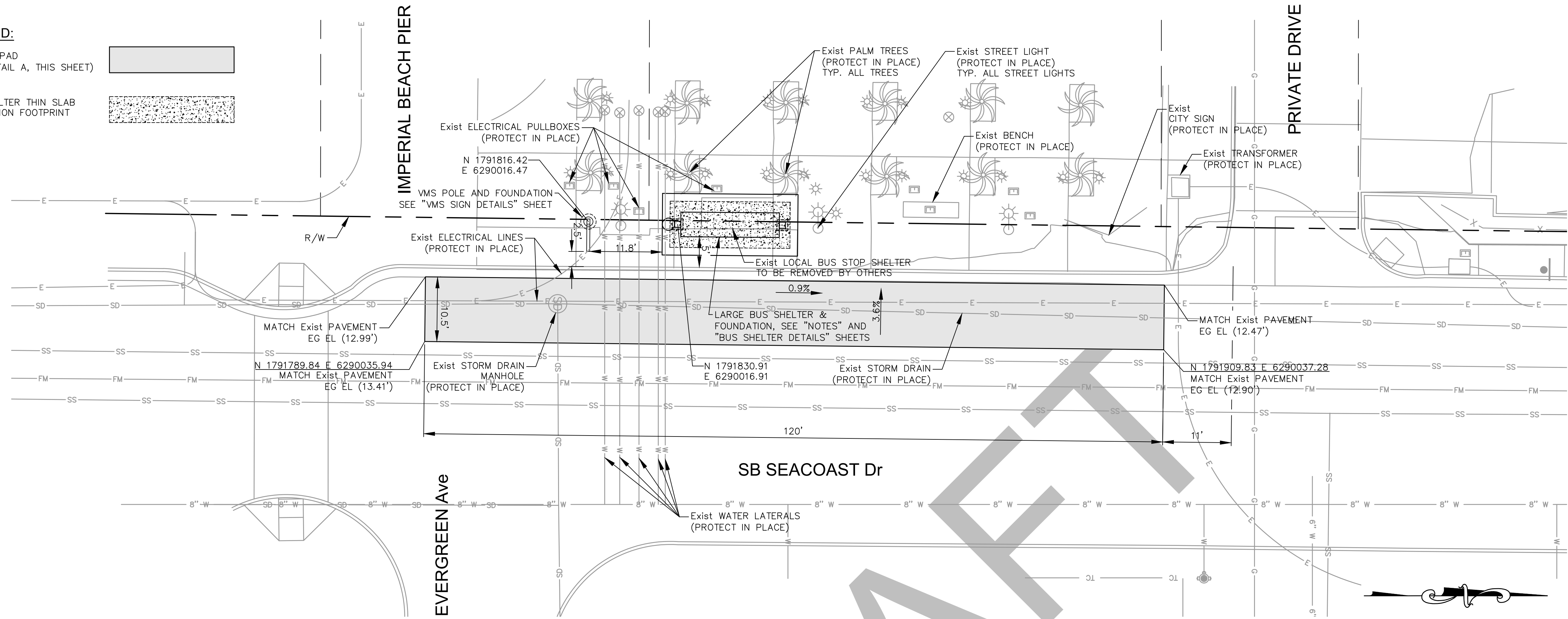

**DETAIL A**  
NOT TO SCALE

**PLAN**

SCALE: 1" = 10'



GRAPHIC SCALE

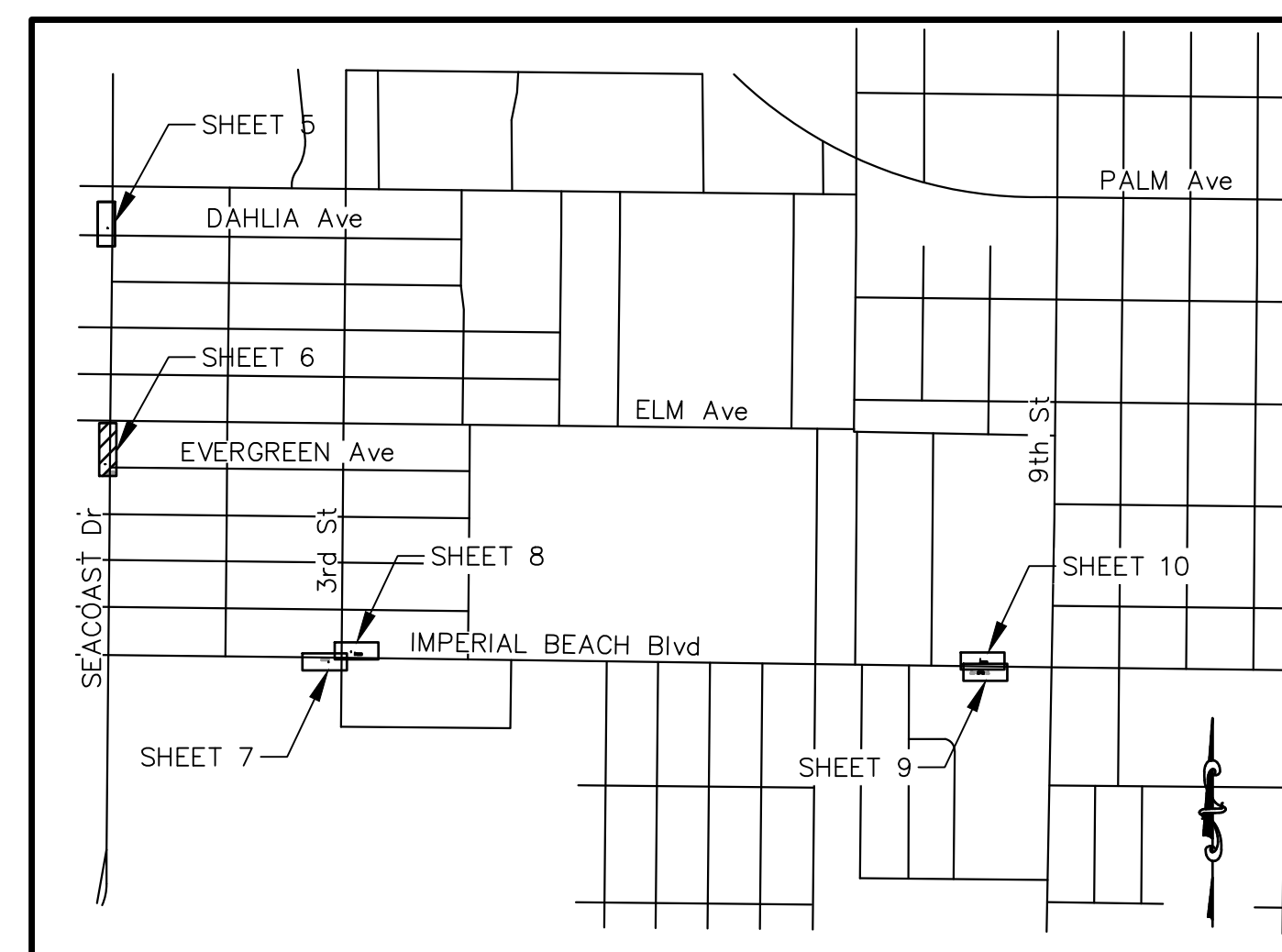

**KEYMAP**  
NOT TO SCALE

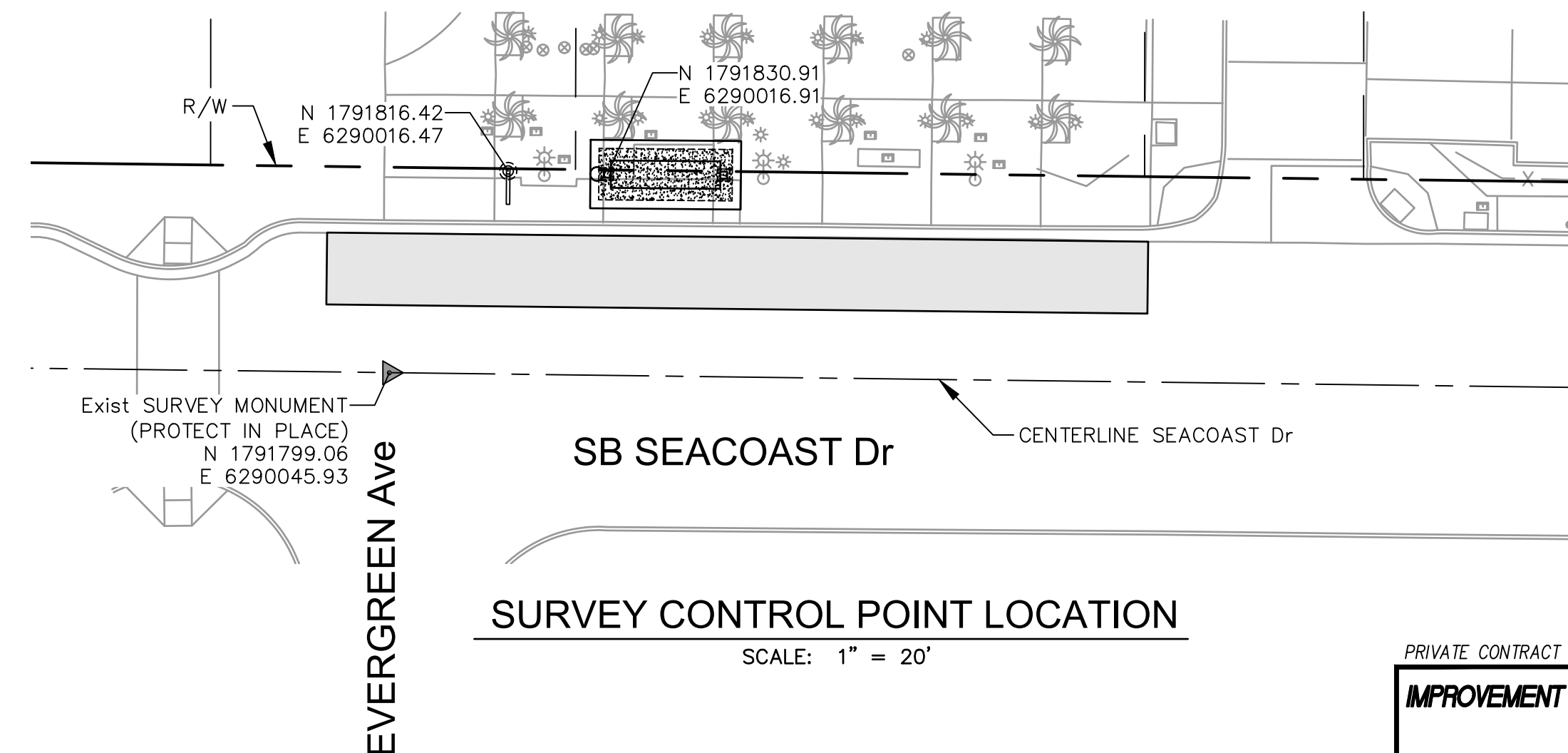

**SURVEY CONTROL POINT LOCATION**  
SCALE: 1" = 20'

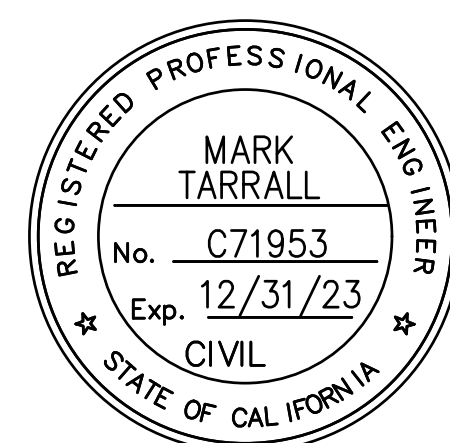

*Mark Tarrall*  
MARK TARRALL R.C.E. NO. 71953 EXP. 12-31-23

DOKKEN ENGINEERING  
1450 FRAZEE ROAD, SUITE 100  
(858) 514-8377

DATE

**NOTE:**

THE CITY OF SAN DIEGO ENGINEER DOES NOT CONSTITUTE APPROVAL OF THIS SHEET AS IT ONLY REFLECTS IMPROVEMENTS LOCATED WITHIN CITY OF IMPERIAL BEACH JURISDICTION.

PRIVATE CONTRACT		<b>IMPROVEMENT PLANS FOR IRIS RAPID CORRIDOR AND STATION DESIGN</b> IMPERIAL BEACH BLVD/CORONADO AVE	
CITY OF IMPERIAL BEACH, CALIFORNIA		PROJECT NO. XXXXXX	
SHEET 6 OF 42 SHEETS		V.T.M.	
DESCRIPTION	BY	APPROVED	DATE FILMED
AS-BUILTS			
CONTRACTOR	DATE STARTED		1786-6299
INSPECTOR	DATE COMPLETED		NAD83 COORDINATES
			146-1739
			LAMBERT COORDINATES
			<b>06-D</b>

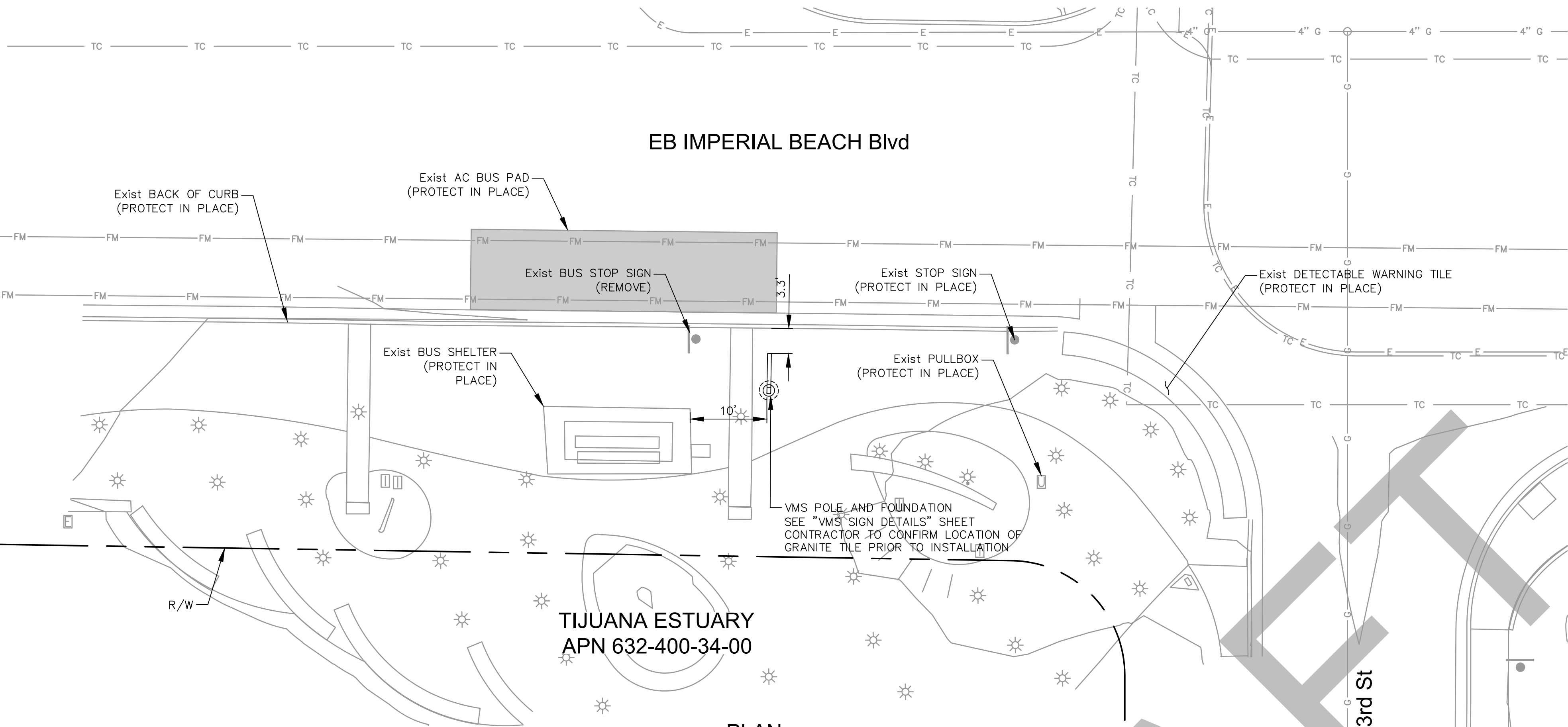

TIJUANA ESTUARY  
APN 632-400-34-00

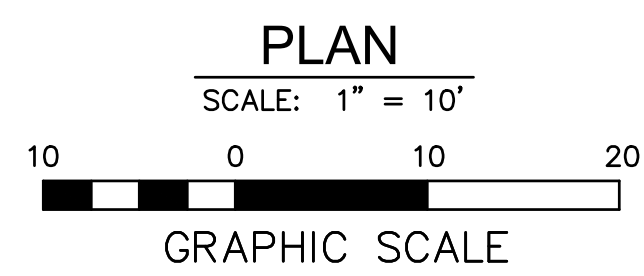

**LEGEND:**  
Exist AC BUS PAD  
(6" HMA OVER 20" AB)

DRAFT

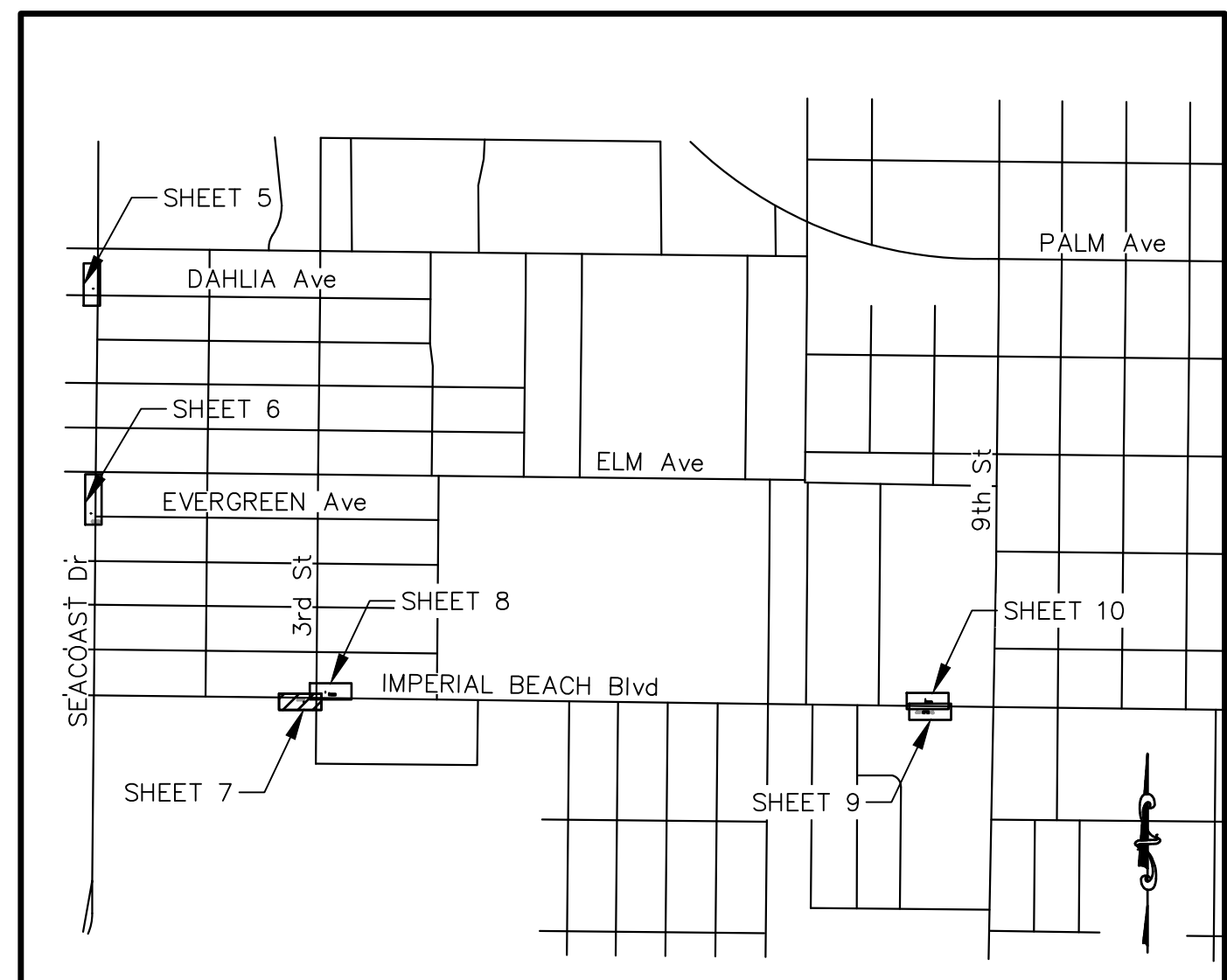

**KEYMAP**  
NOT TO SCALE

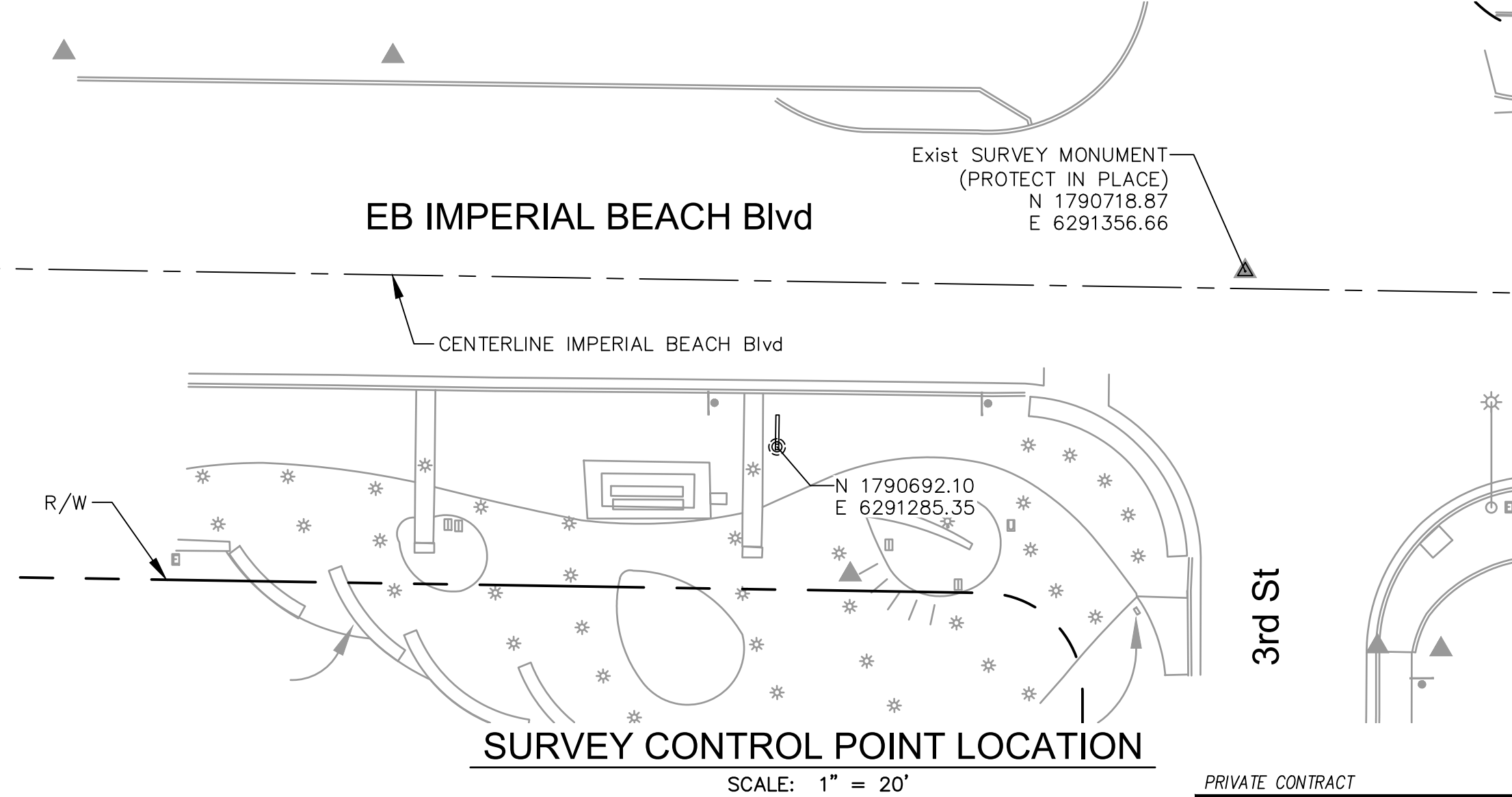

*Mark Tarrall*  
MARK TARRALL R.C.E. NO. 71953 EXP. 12-31-23

DOKKEN ENGINEERING  
1450 FRAZEE ROAD, SUITE 100  
(858) 514-8377

**NOTE:**  
THE CITY OF SAN DIEGO ENGINEER DOES NOT CONSTITUTE APPROVAL OF THIS SHEET AS IT ONLY REFLECTS IMPROVEMENTS LOCATED WITHIN CITY OF IMPERIAL BEACH JURISDICTION.

<b>IMPROVEMENT PLANS FOR IRIS RAPID CORRIDOR AND STATION DESIGN IMPERIAL BEACH BLVD/CORONADO AVE</b>			
CITY OF IMPERIAL BEACH, CALIFORNIA		PROJECT NO. XXXXXX	
SHEET 7 OF 42 SHEETS		V.T.M.	
DESCRIPTION	BY	APPROVED	DATE FILMED
AS-BUILTS			
CONTRACTOR		DATE STARTED	
INSPECTOR		DATE COMPLETED	
<b>07-D</b>			

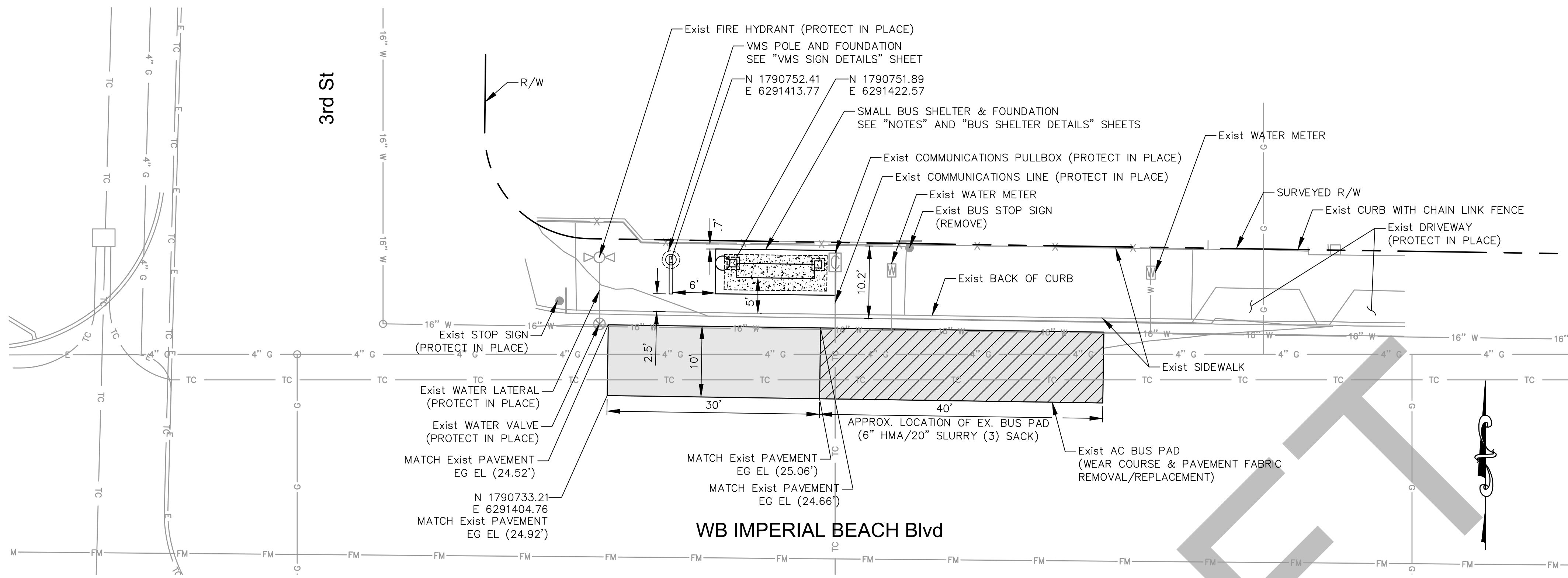

**PLAN**  
SCALE: 1" = 10'  
GRAPHIC SCALE

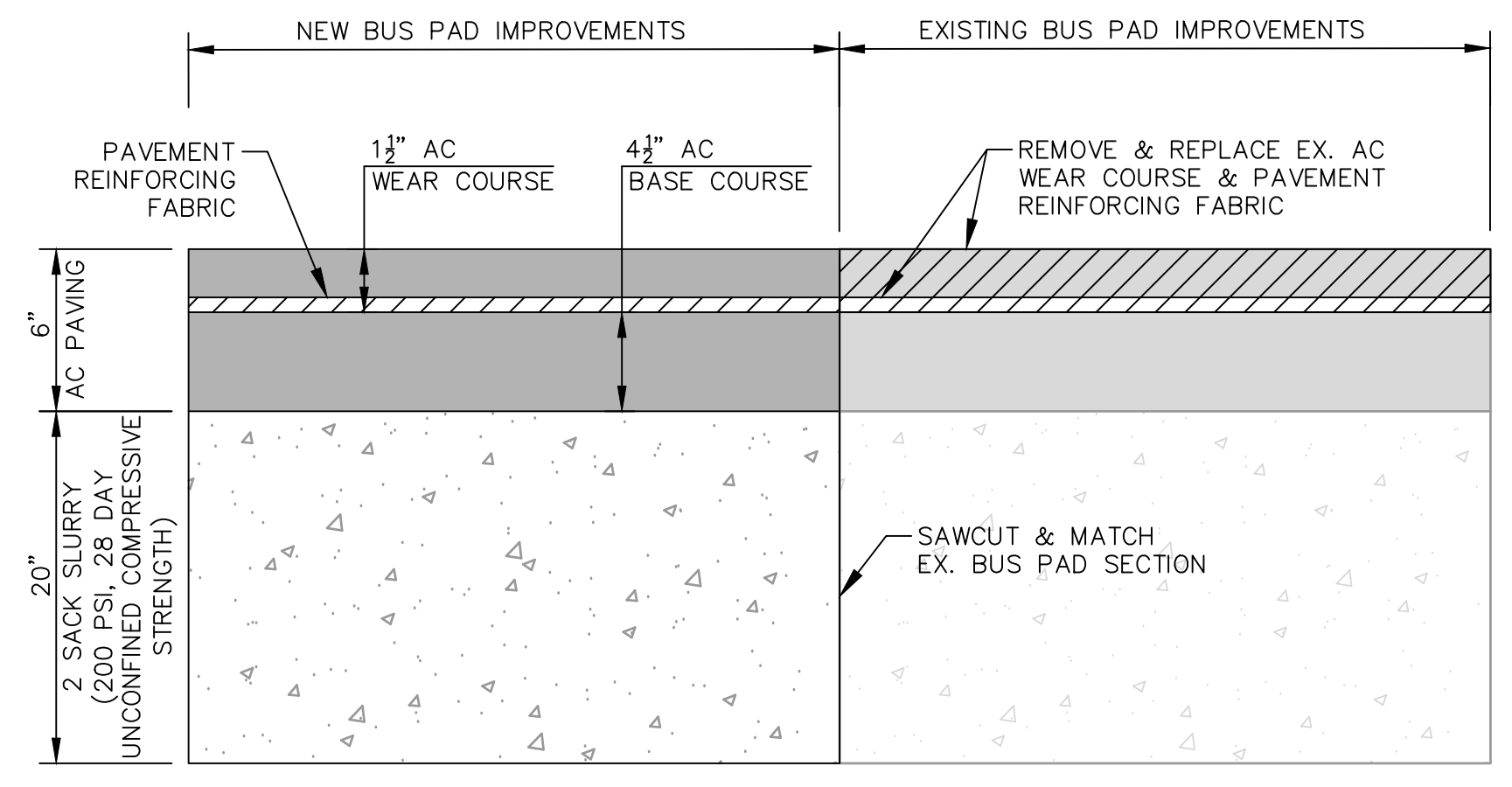

**DETAIL A**  
NOT TO SCALE

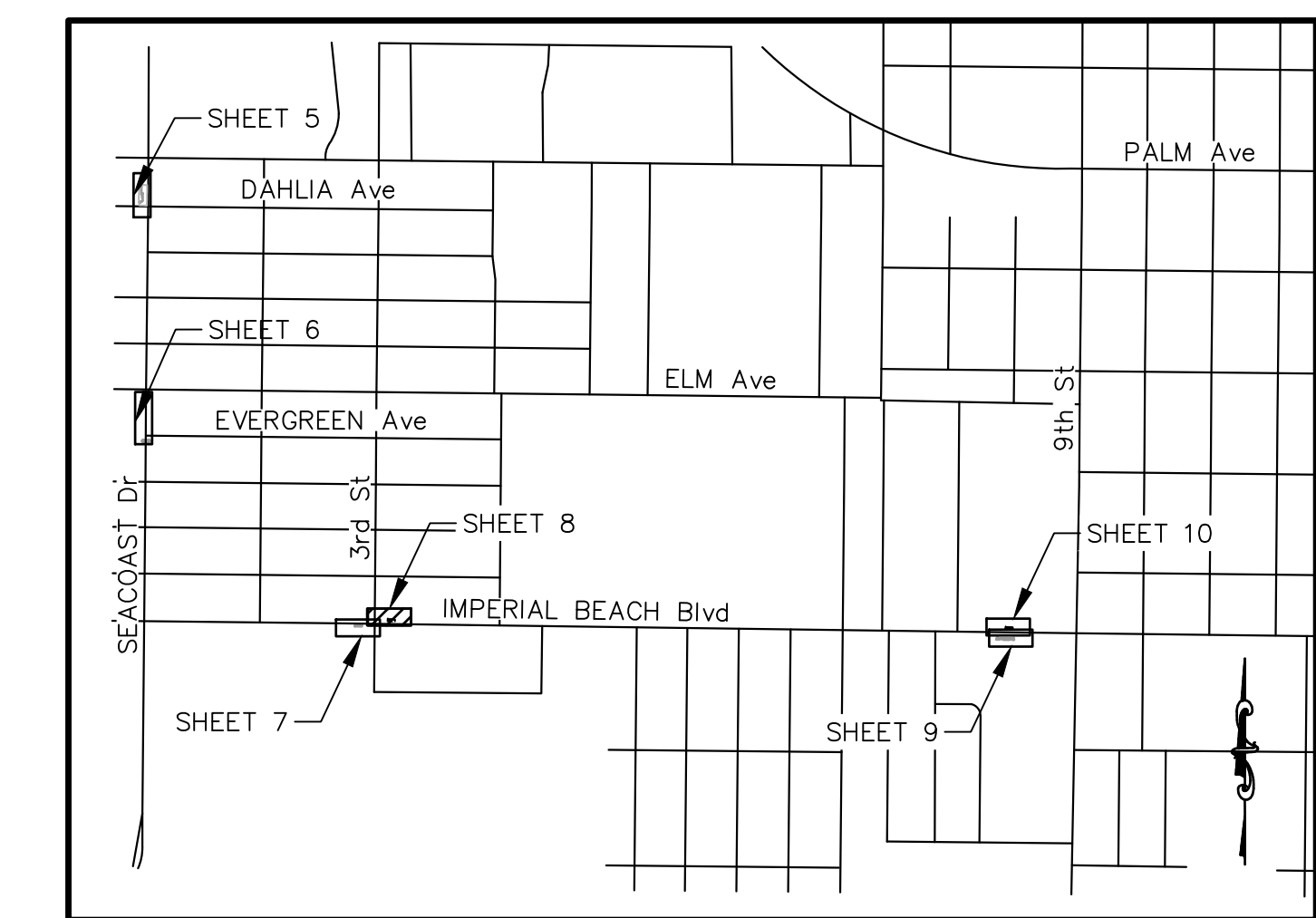

**KEYMAP**  
NOT TO SCALE

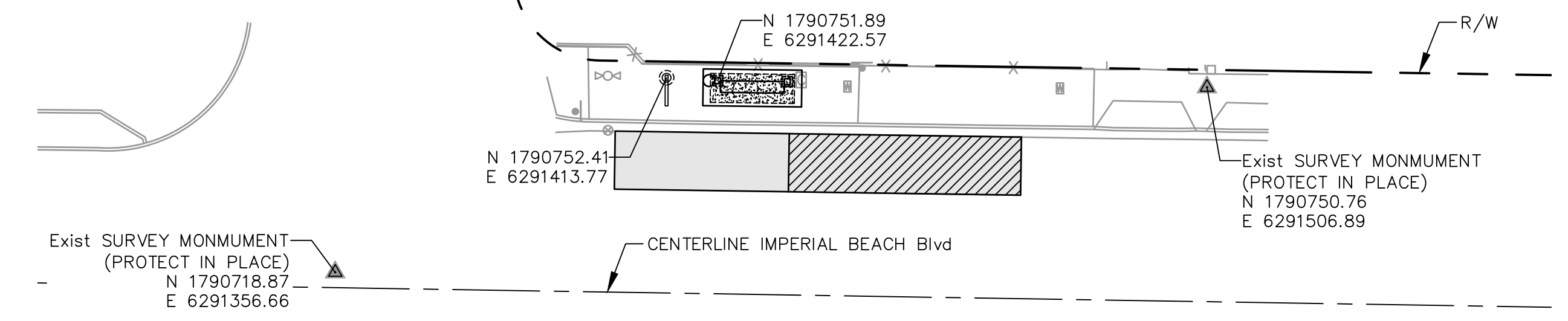

**SURVEY CONTROL POINT LOCATION**  
SCALE: 1" = 20'

- NOTES:**
1. PROVIDE BUS SHELTER CLEARANCES PER SHEET 3 DIMENSIONS (UNLESS OTHERWISE NOTED).
  2. ALL ROADWAY STRIPING AFFECTED BY BUS PAD INSTALLATION SHALL BE REPLACED IN KIND.

- LEGEND:**
- AC BUS PAD (SEE DETAIL A, THIS SHEET)
  - EXIST BUS PAD AC WEAR COURSE & PAVEMENT FABRIC REMOVAL/REPLACEMENT
  - BUS SHELTER THIN SLAB FOUNDATION FOOTPRINT

DRAFT

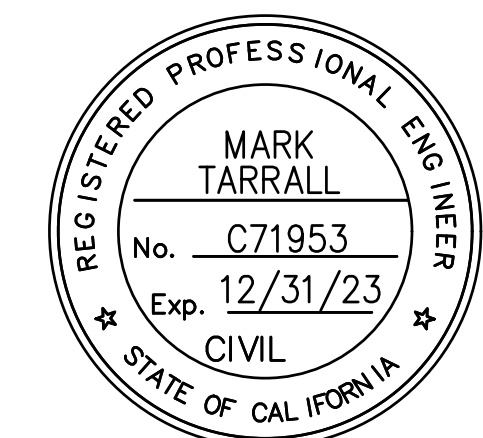

*Mark Tarrall*  
MARK TARRALL R.C.E. NO. 71953 EXP. 12-31-23

DOKKEN ENGINEERING  
1450 FRAZEE ROAD, SUITE 100  
(858) 514-8377

**NOTE:**  
THE CITY OF SAN DIEGO ENGINEER DOES NOT CONSTITUTE APPROVAL OF THIS SHEET AS IT ONLY REFLECTS IMPROVEMENTS LOCATED WITHIN CITY OF IMPERIAL BEACH JURISDICTION.

IMPROVEMENT PLANS FOR: <b>IRIS RAPID CORRIDOR AND STATION DESIGN</b> IMPERIAL BEACH BLVD/CORONADO AVE			
CITY OF IMPERIAL BEACH, CALIFORNIA		PROJECT NO. XXXXXX	
SHEET 8 OF 42 SHEETS		V.T.M.	
DESCRIPTION	BY	APPROVED	DATE FILMED
AS-BUILTS			
CONTRACTOR	DATE STARTED		
INSPECTOR	DATE COMPLETED		
		1786-6299	NAD83 COORDINATES
		146-1739	LAMBERT COORDINATES
		<b>08-D</b>	



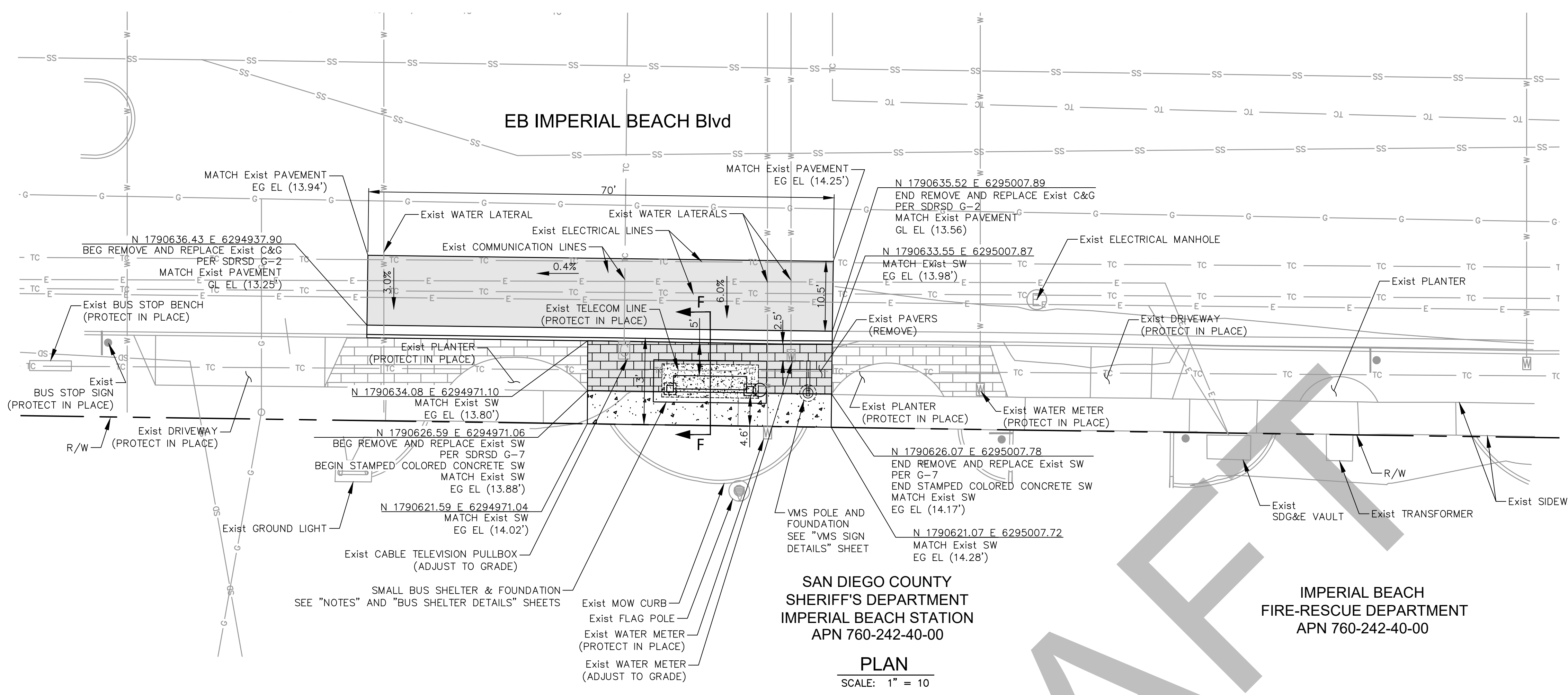

- NOTES:**
1. PROVIDE BUS SHELTER CLEARANCES PER SHEET 3 DIMENSIONS (UNLESS OTHERWISE NOTED).
  2. ALL ROADWAY STRIPING AFFECTED BY BUS PAD INSTALLATION SHALL BE REPLACED IN KIND.
  3. ALL NEW CURB SHOULD BE PAINTED RED IN ORDER TO PREVENT PARKING ALONG THE PROPOSED BUS STOP LOCATION.

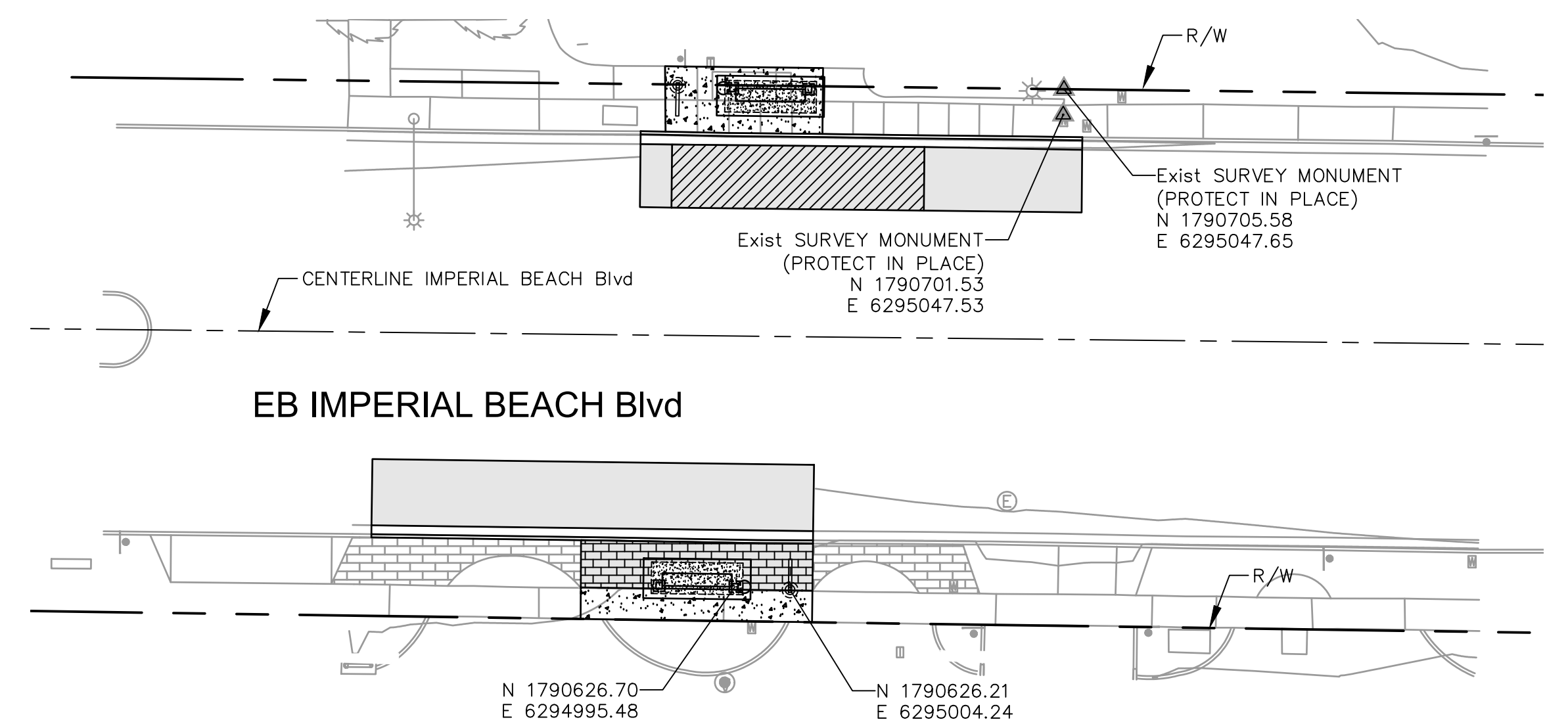
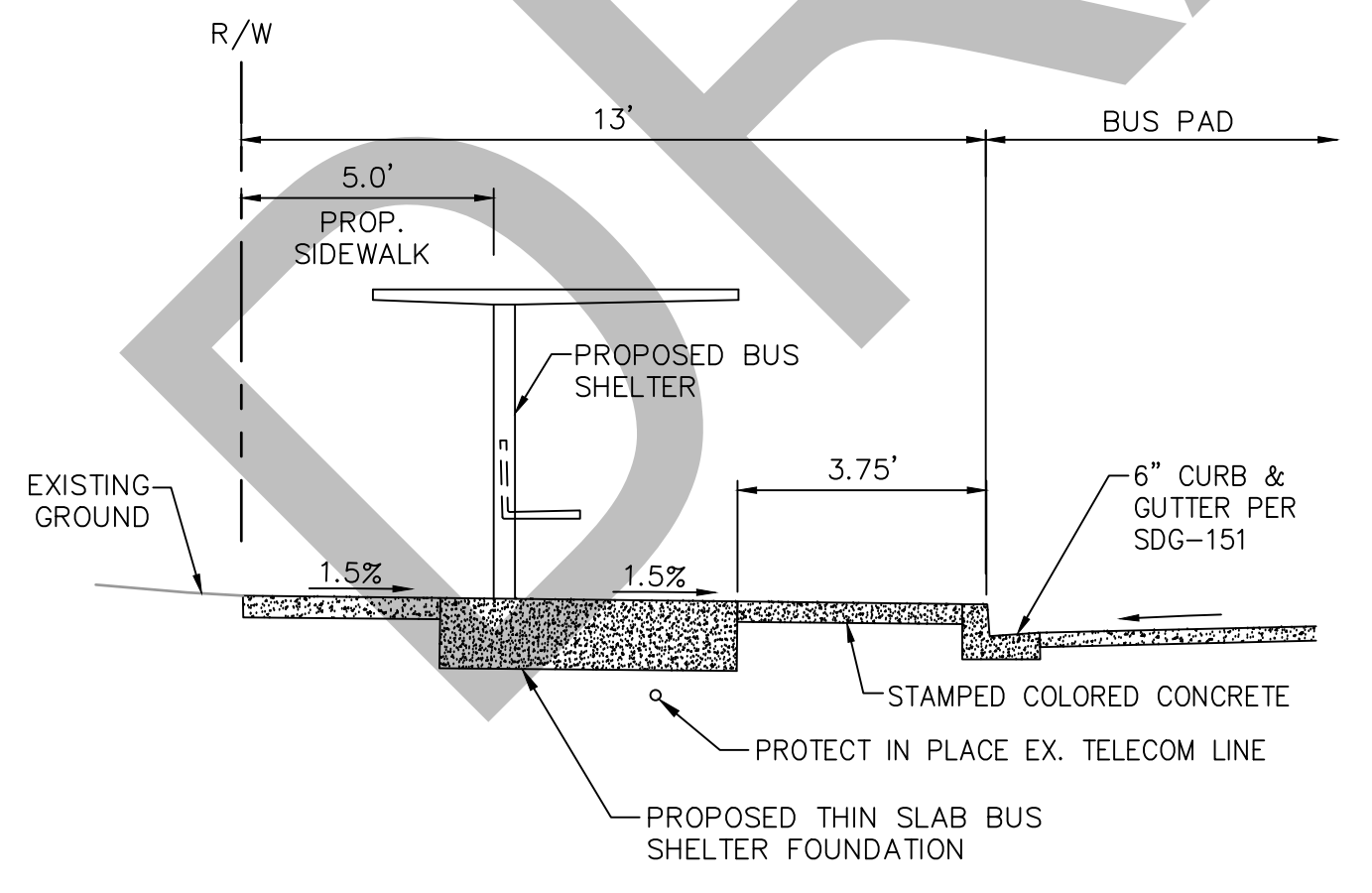
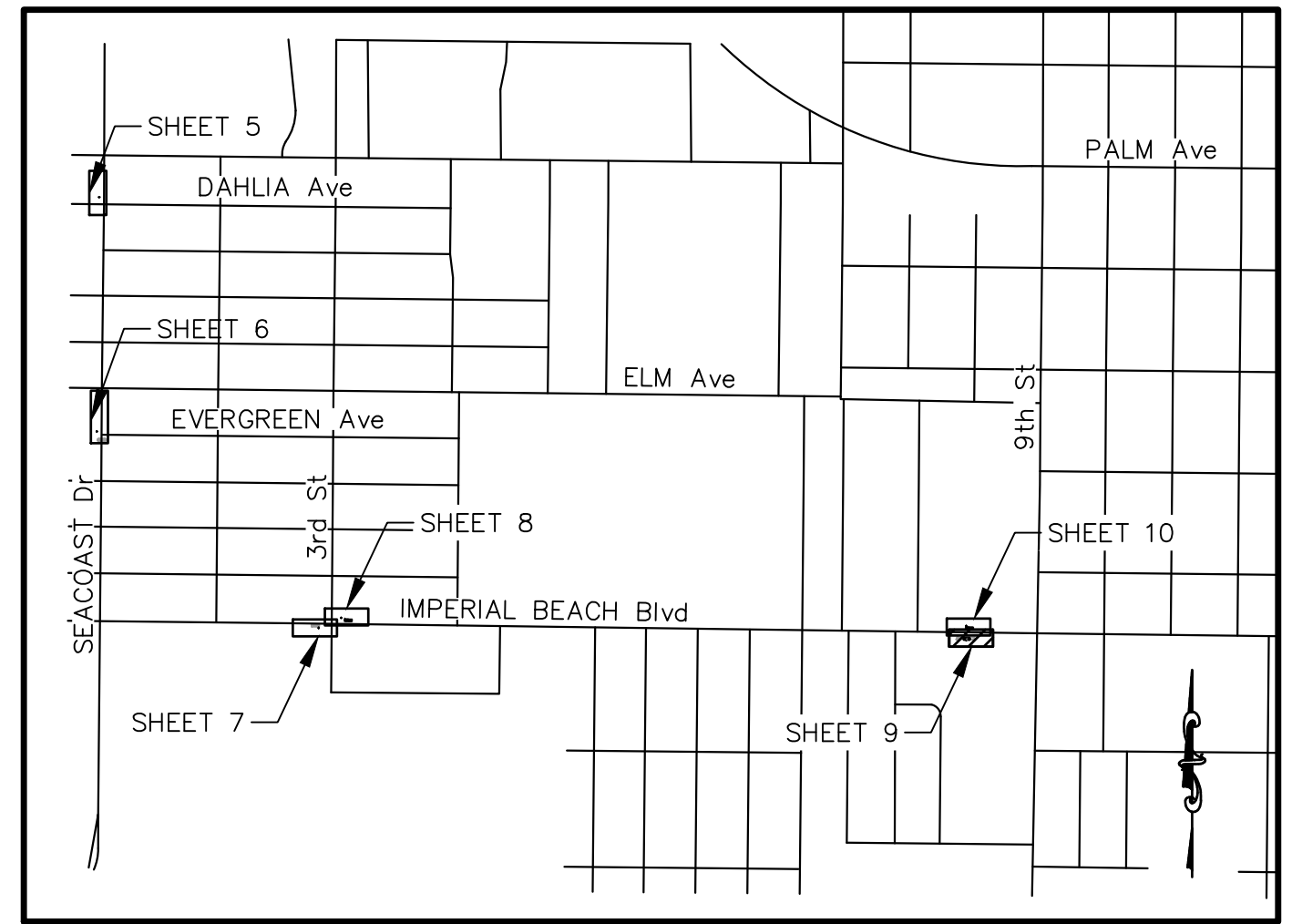
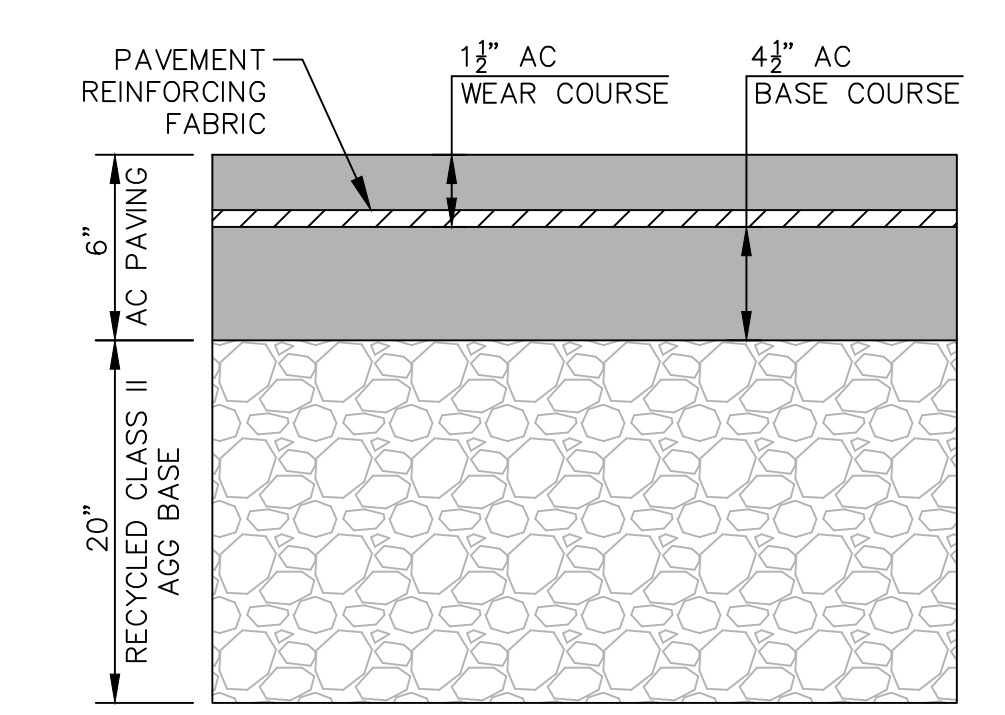
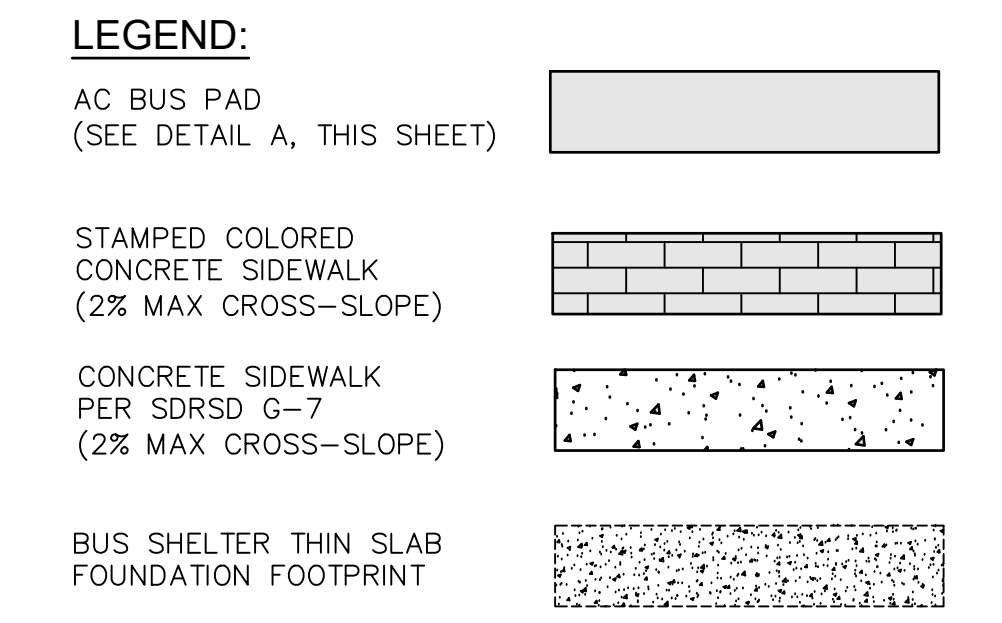

PRIVATE CONTRACT

**IMPROVEMENT PLANS FOR IRIS RAPID CORRIDOR AND STATION DESIGN IMPERIAL BEACH BLVD/CORONADO AVE**

CITY OF IMPERIAL BEACH, CALIFORNIA		PROJECT NO. XXXXXX
SHEET 9 OF 42 SHEETS		V.T.M.
DESCRIPTION	BY	APPROVED
		DATE
		FILMED
AS-BUILTS		
CONTRACTOR		DATE STARTED
INSPECTOR		DATE COMPLETED

1786-6299 NAD83 COORDINATES  
146-1739 LAMBERT COORDINATES

**09-D**

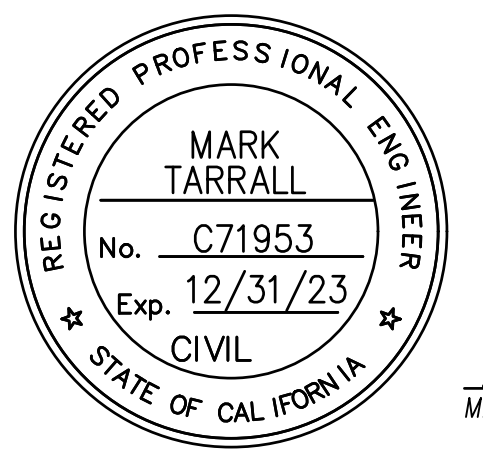

*Mark Tarrall*  
MARK TARRALL R.C.E. NO. 71953 EXP. 12-31-23

DOKKEN ENGINEERING  
1450 FRAZEE ROAD, SUITE 100  
(858) 514-8377

**NOTE:**  
THE CITY OF SAN DIEGO ENGINEER DOES NOT CONSTITUTE APPROVAL OF THIS SHEET AS IT ONLY REFLECTS IMPROVEMENTS LOCATED WITHIN CITY OF IMPERIAL BEACH JURISDICTION.

**LEGEND:**

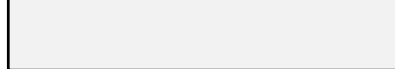
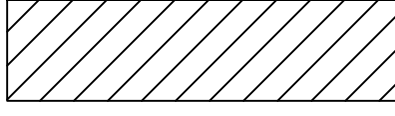
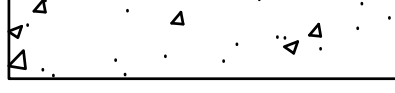
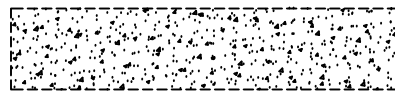
- AC BUS PAD  
(SEE DETAIL A, THIS SHEET) 
- Exist BUS PAD AC WEAR COURSE & PAVEMENT FABRIC REMOVAL/REPLACEMENT 
- CONCRETE SIDEWALK PER SDRSD G-7 (2% MAX CROSS-SLOPE) 
- BUS SHELTER THIN SLAB FOUNDATION FOOTPRINT 

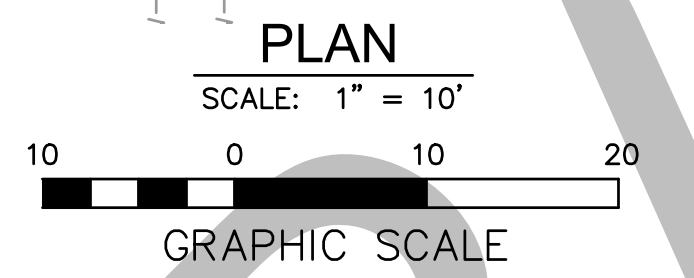
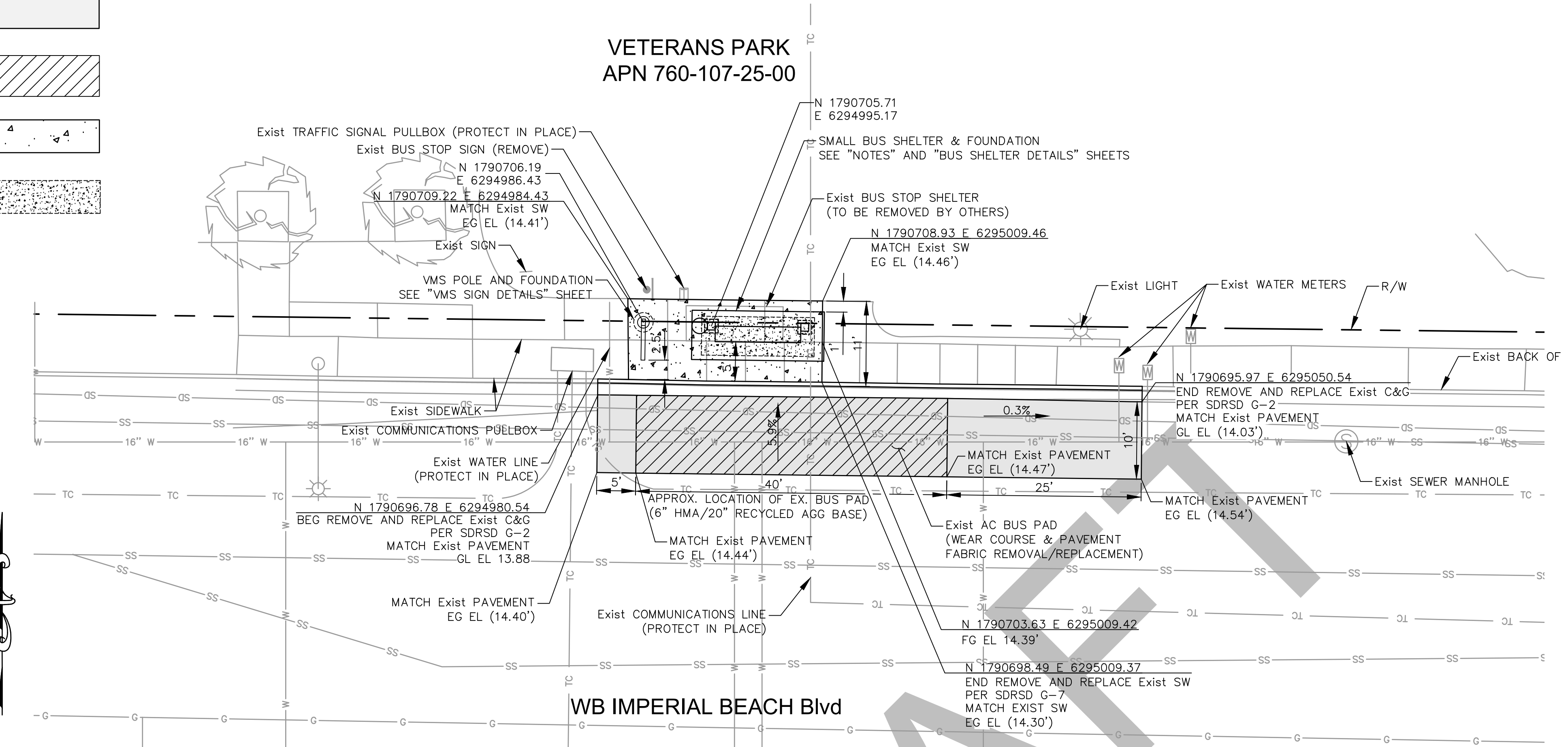

**NOTES:**

1. PROVIDE BUS SHELTER CLEARANCES PER SHEET 3 DIMENSIONS (UNLESS OTHERWISE NOTED).
2. ALL ROADWAY STRIPING AFFECTED BY BUS PAD INSTALLATION SHALL BE REPLACED IN KIND.
3. ALL NEW CURB SHOULD BE PAINTED RED IN ORDER TO PREVENT PARKING ALONG THE PROPOSED BUS STOP LOCATION.
4. COORDINATE FURNITURE REMOVAL (BY OTHERS) WITH MTS.

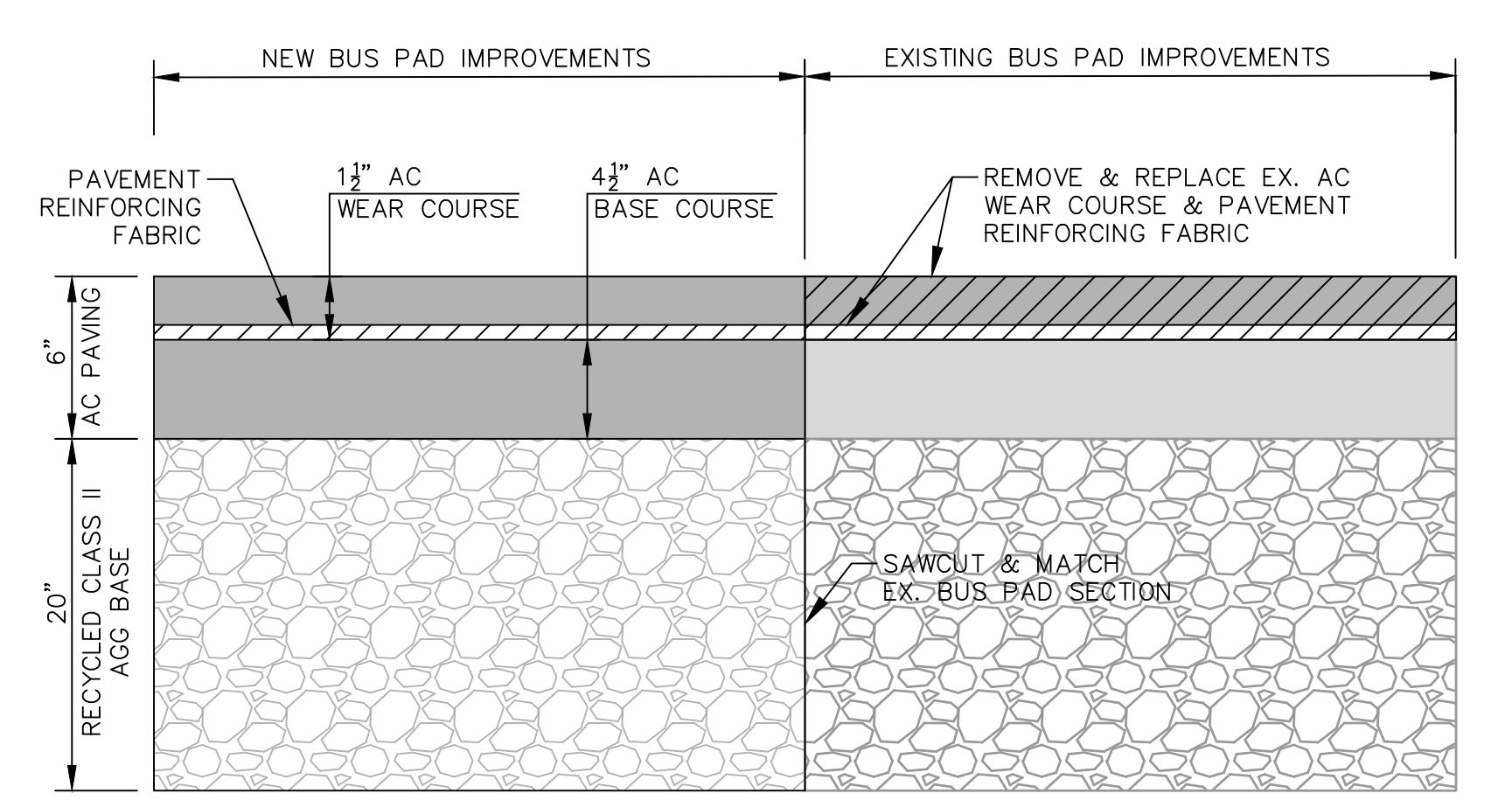

**DETAIL A**  
NOT TO SCALE

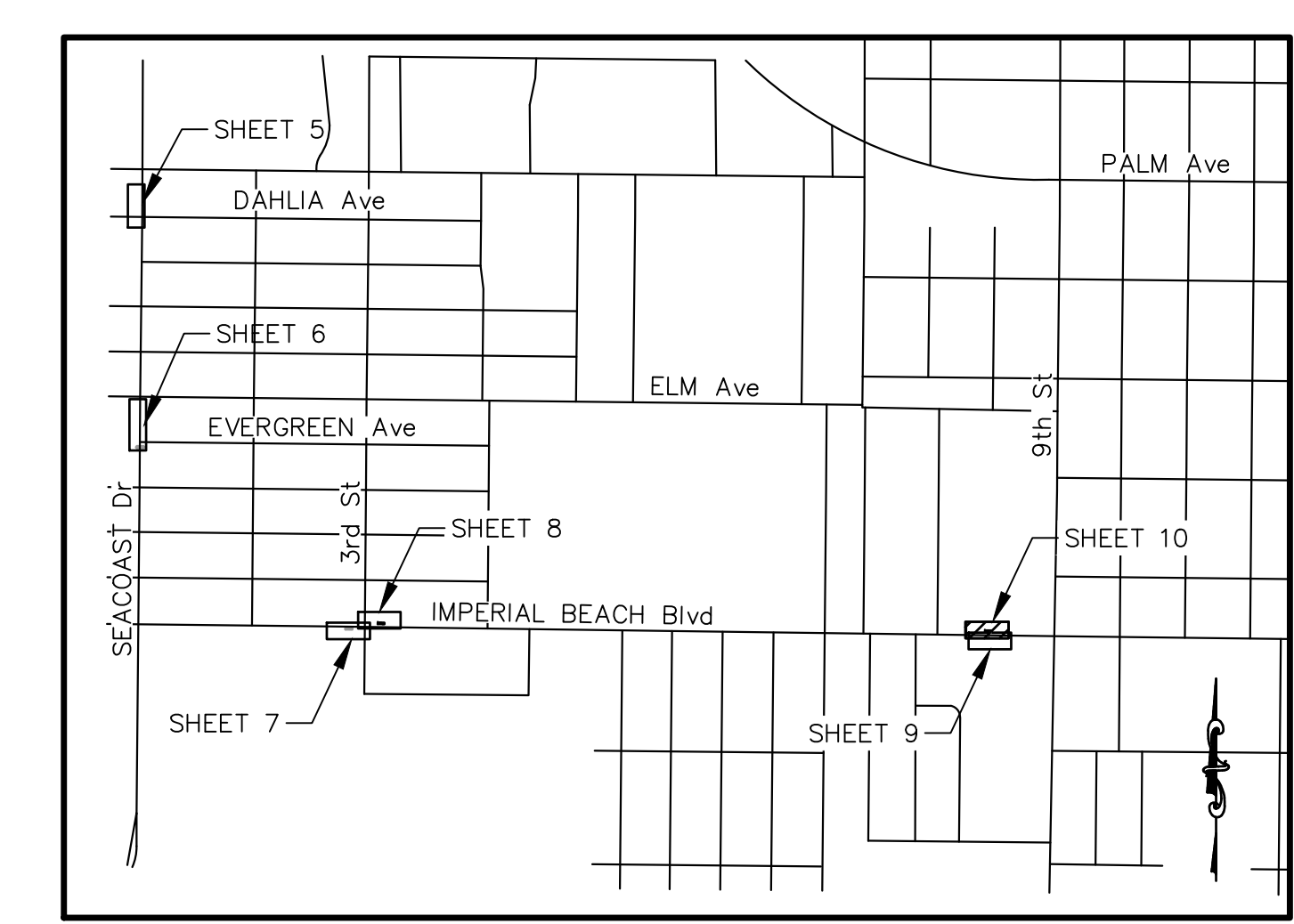

**KEYMAP**  
NOT TO SCALE

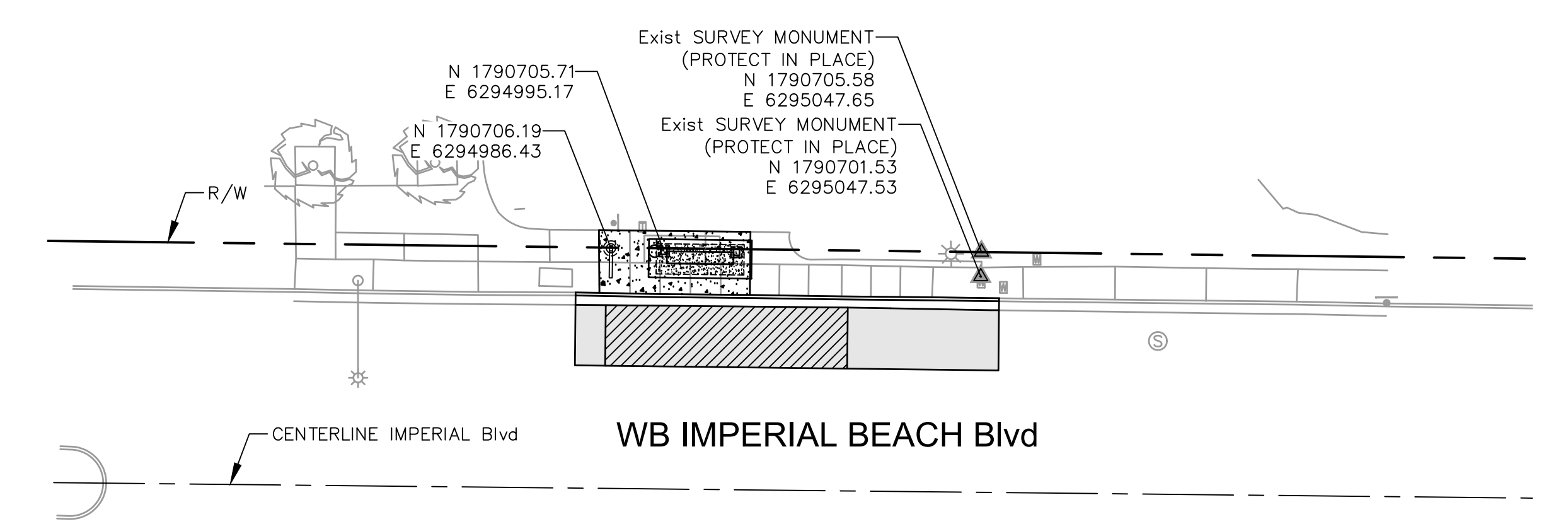

**SURVEY CONTROL POINT LOCATION**  
SCALE: 1" = 20'

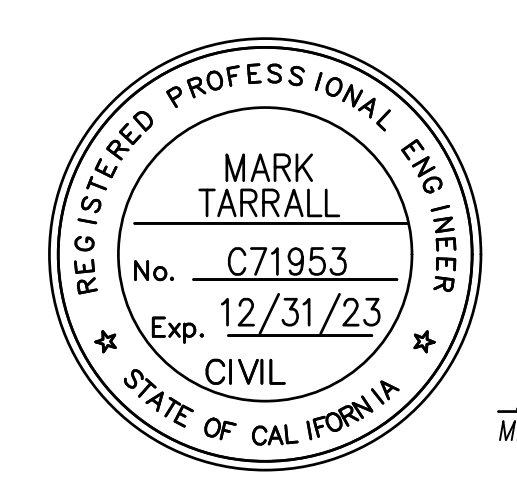

*Mark Tarrall*  
MARK TARRALL R.C.E. NO. 71953 EXP. 12-31-23

DOKKEN ENGINEERING  
1450 FRAZEE ROAD, SUITE 100  
(858) 514-8377

**NOTE:**  
THE CITY OF SAN DIEGO ENGINEER DOES NOT CONSTITUTE APPROVAL OF THIS SHEET AS IT ONLY REFLECTS IMPROVEMENTS LOCATED WITHIN CITY OF IMPERIAL BEACH JURISDICTION.

PRIVATE CONTRACT			
<b>IMPROVEMENT PLANS FOR IRIS RAPID CORRIDOR AND STATION DESIGN</b> IMPERIAL BEACH BLVD/CORONADO AVE			
CITY OF IMPERIAL BEACH, CALIFORNIA		PROJECT NO. XXXXXX	
SHEET 10 OF 42 SHEETS		V.T.M.	
DESCRIPTION	BY	APPROVED	DATE FILMED
AS-BUILTS			
CONTRACTOR	DATE STARTED		
INSPECTOR	DATE COMPLETED		
		1786-6299 NAD83 COORDINATES 146-1739 LAMBERT COORDINATES	
		<b>10-D</b>	

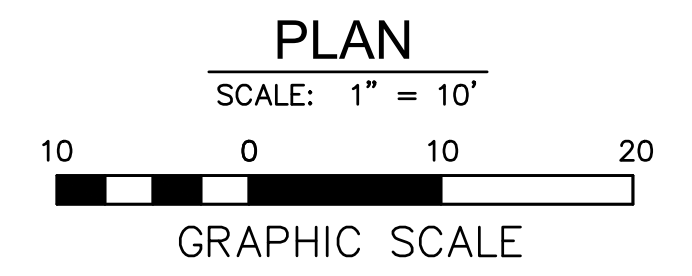
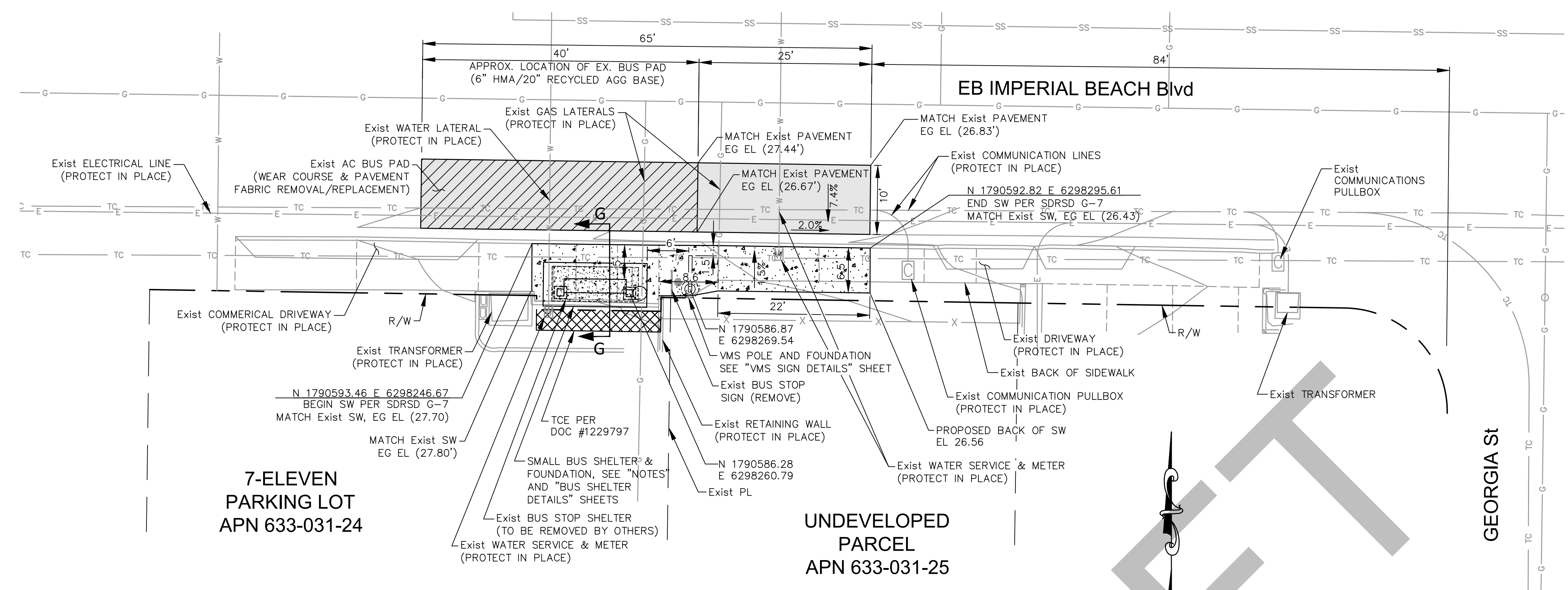

- NOTES:**
1. PROVIDE BUS SHELTER CLEARANCES PER SHEET 3 DIMENSIONS (UNLESS NOTED OTHERWISE).
  2. ALL ROADWAY STRIPING AFFECTED BY BUS PAD INSTALLATION SHALL BE REPLACED IN KIND
  3. COORDINATE FURNITURE REMOVAL (BY OTHERS) WITH MTS.

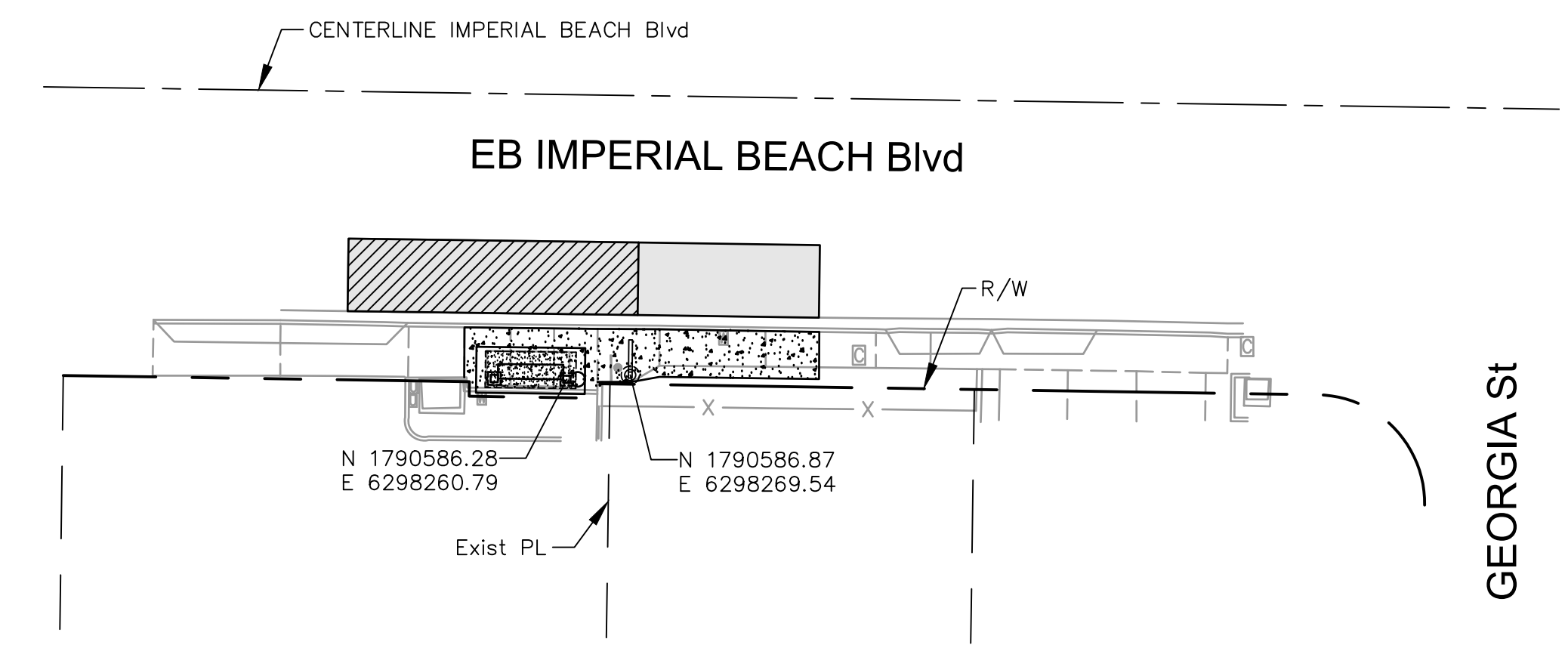
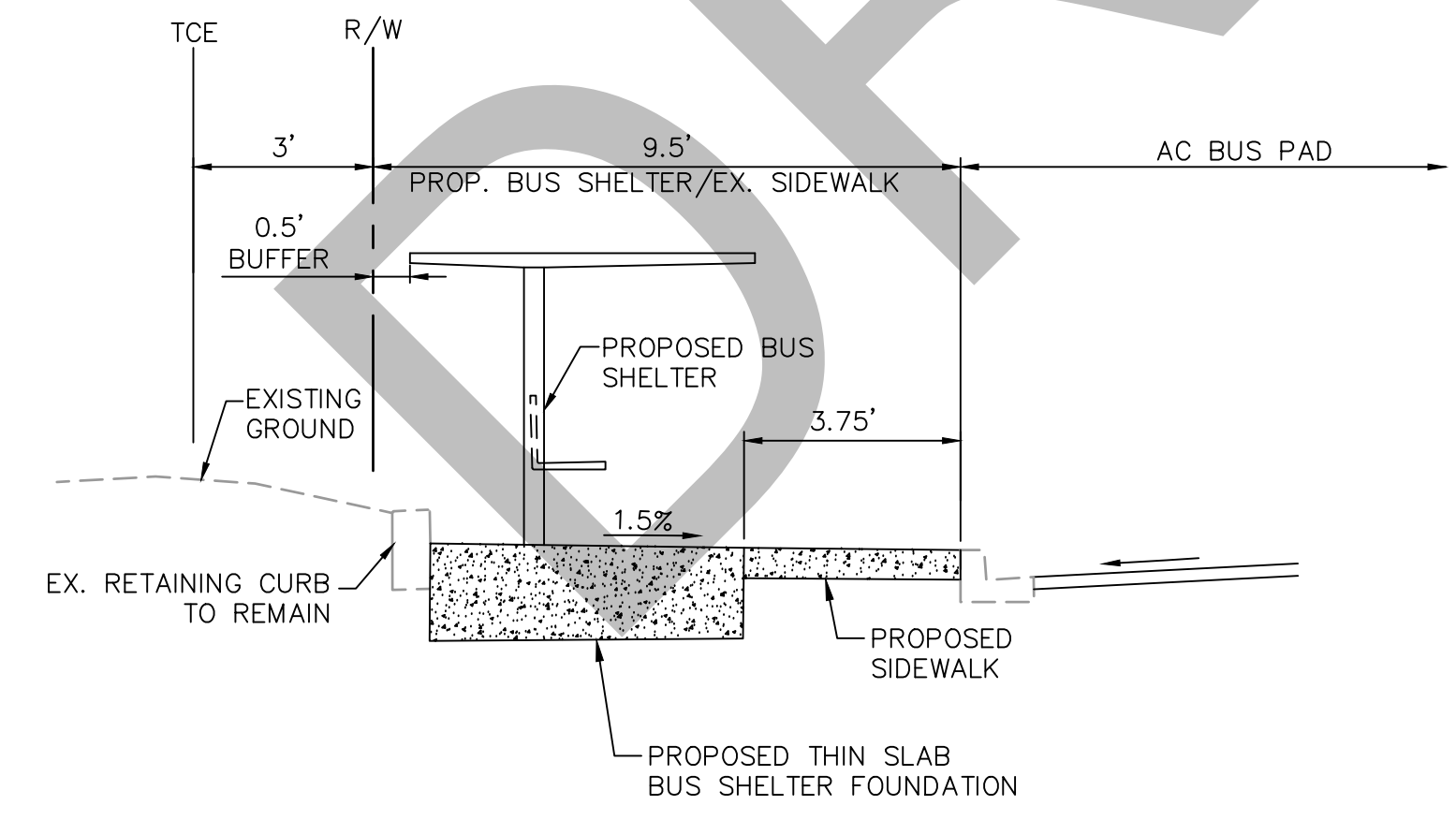
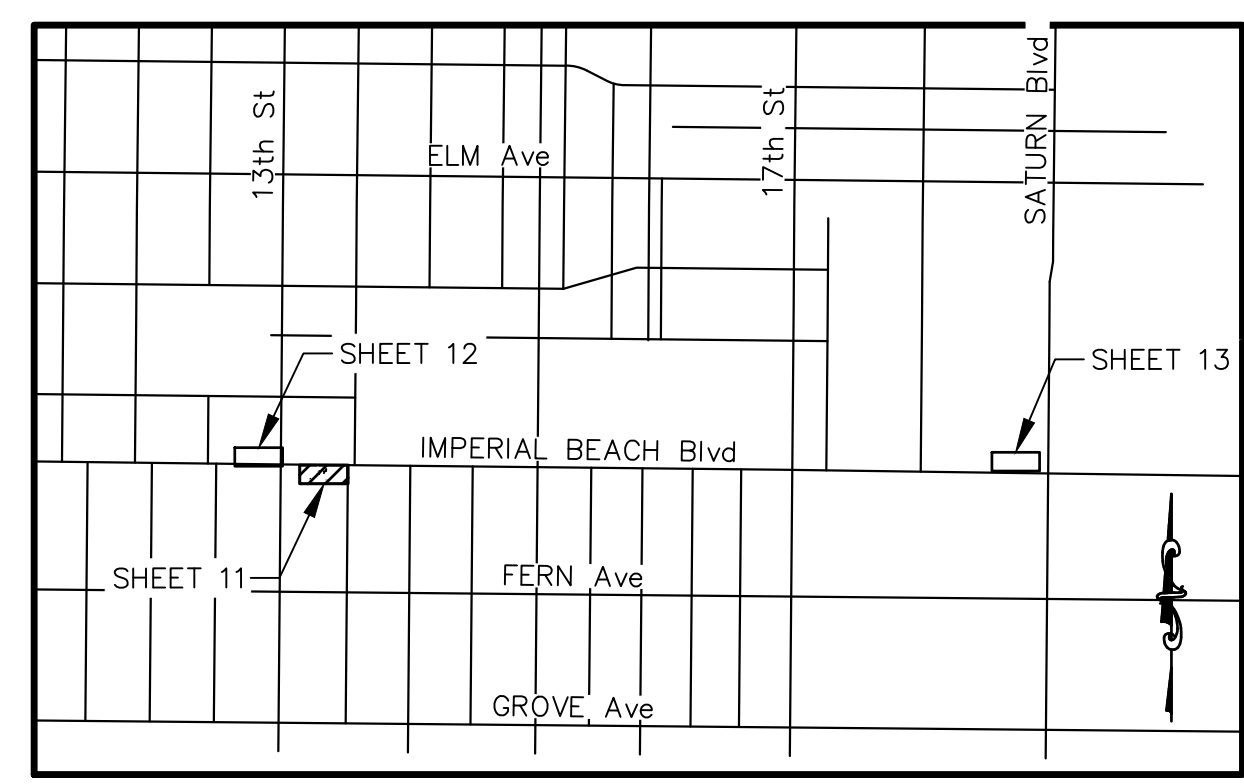
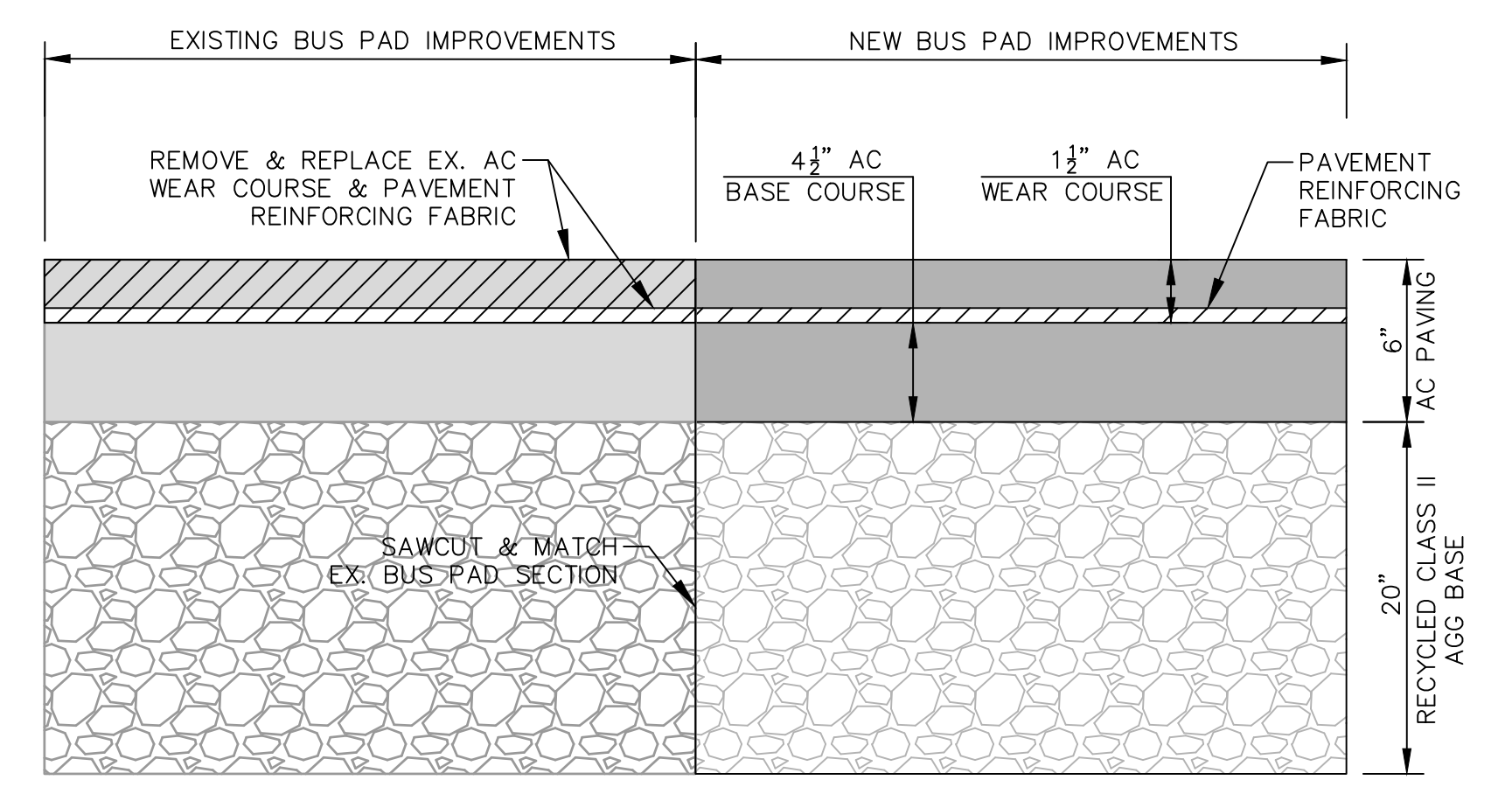
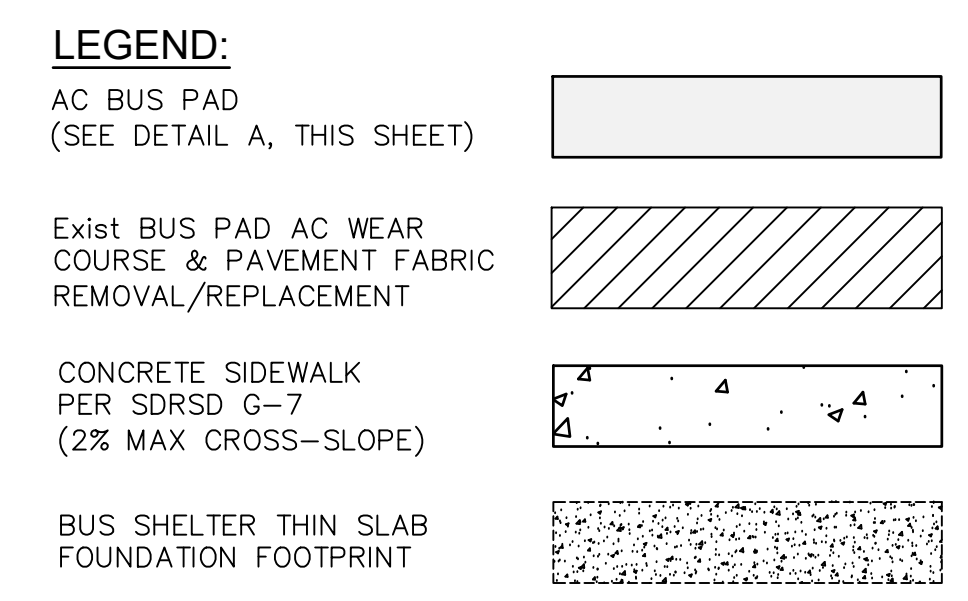

**DETAIL A**  
NOT TO SCALE

**SURVEY CONTROL POINT LOCATION**  
SCALE: 1" = 20'

**SECTION G-G**  
NOT TO SCALE

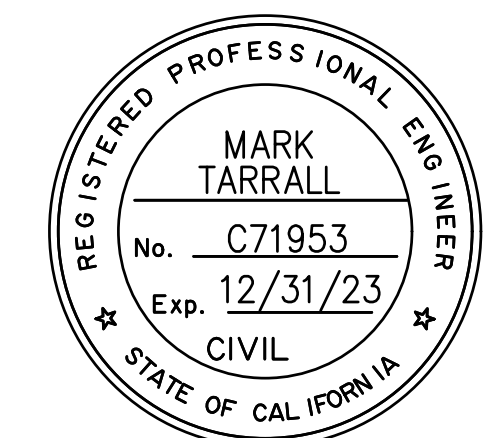

*Mark Tarrall*  
MARK TARRALL R.C.E. NO. 71953 EXP. 12-31-23

DOKKEN ENGINEERING  
1450 FRAZEE ROAD, SUITE 100  
(858) 514-8377

**NOTE:**  
THE CITY OF SAN DIEGO ENGINEER DOES NOT CONSTITUTE APPROVAL OF THIS SHEET AS IT ONLY REFLECTS IMPROVEMENTS LOCATED WITHIN CITY OF IMPERIAL BEACH JURISDICTION.

IMPROVEMENT PLANS FOR: <b>IRIS RAPID CORRIDOR AND STATION DESIGN</b> IMPERIAL BEACH BLVD/CORONADO AVE			
CITY OF IMPERIAL BEACH, CALIFORNIA		PROJECT NO. XXXXXX	
SHEET 11 OF 42 SHEETS		V.T.M.	
DESCRIPTION	BY	APPROVED	DATE FILMED
AS-BUILTS			
CONTRACTOR	DATE STARTED		
INSPECTOR	DATE COMPLETED		
			11-D

**NOTES:**

1. PROVIDE BUS SHELTER CLEARANCES PER SHEET 3 DIMENSIONS (UNLESS OTHERWISE NOTED).
2. ALL ROADWAY STRIPING AFFECTED BY BUS PAD INSTALLATION SHALL BE REPLACED IN KIND.
3. COORDINATE FURNITURE REMOVAL (BY OTHERS) WITH MTS.

**LEGEND:**

- AC BUS PAD (SEE DETAIL A, THIS SHEET)
- Exist BUS PAD AC WEAR COURSE & PAVEMENT FABRIC REMOVAL/REPLACEMENT
- Exist AC BUS PAD (8" HMA DEEP LIFT OVER ABANDONED ROADWAY)
- BUS SHELTER THIN SLAB FOUNDATION FOOTPRINT

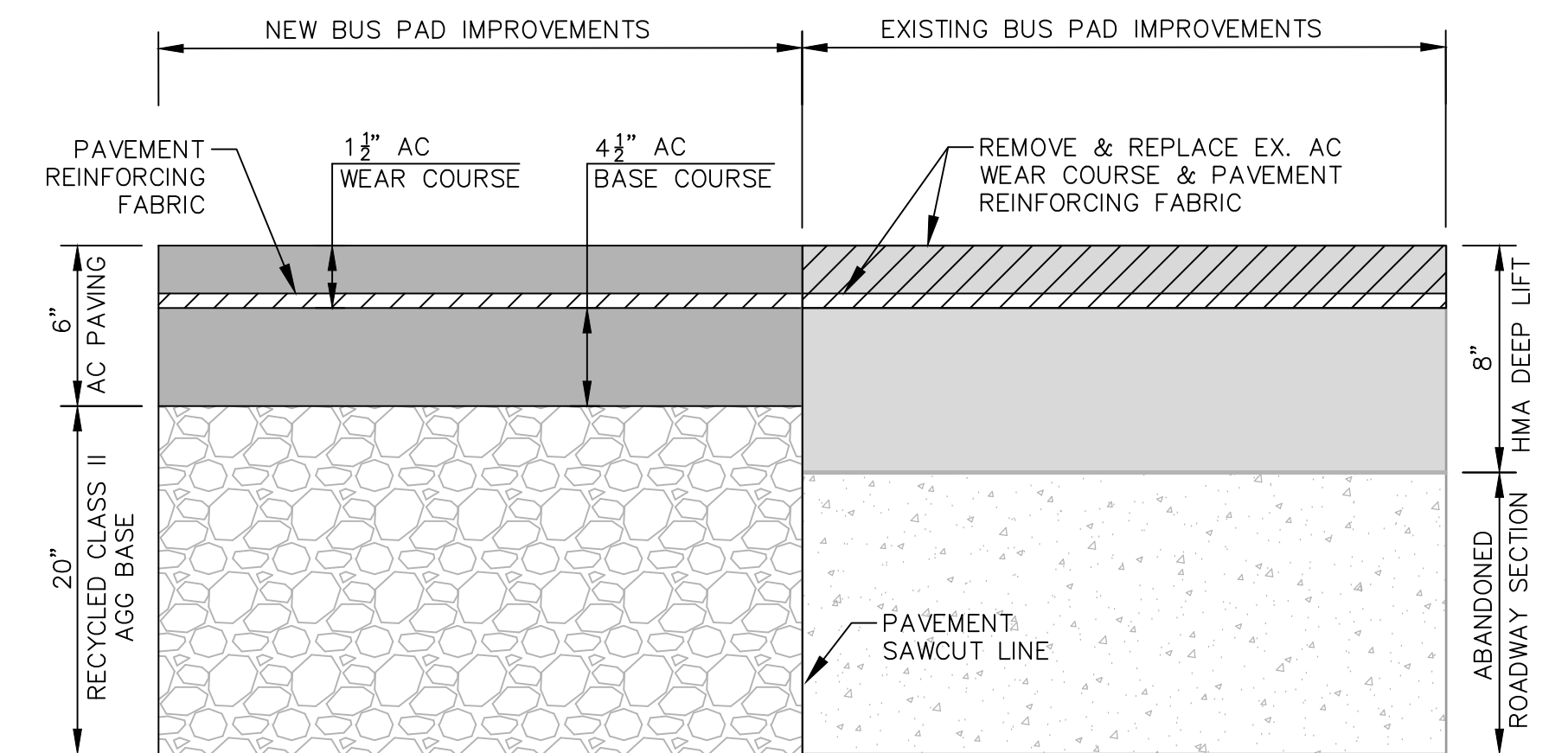

**DETAIL A**  
NOT TO SCALE

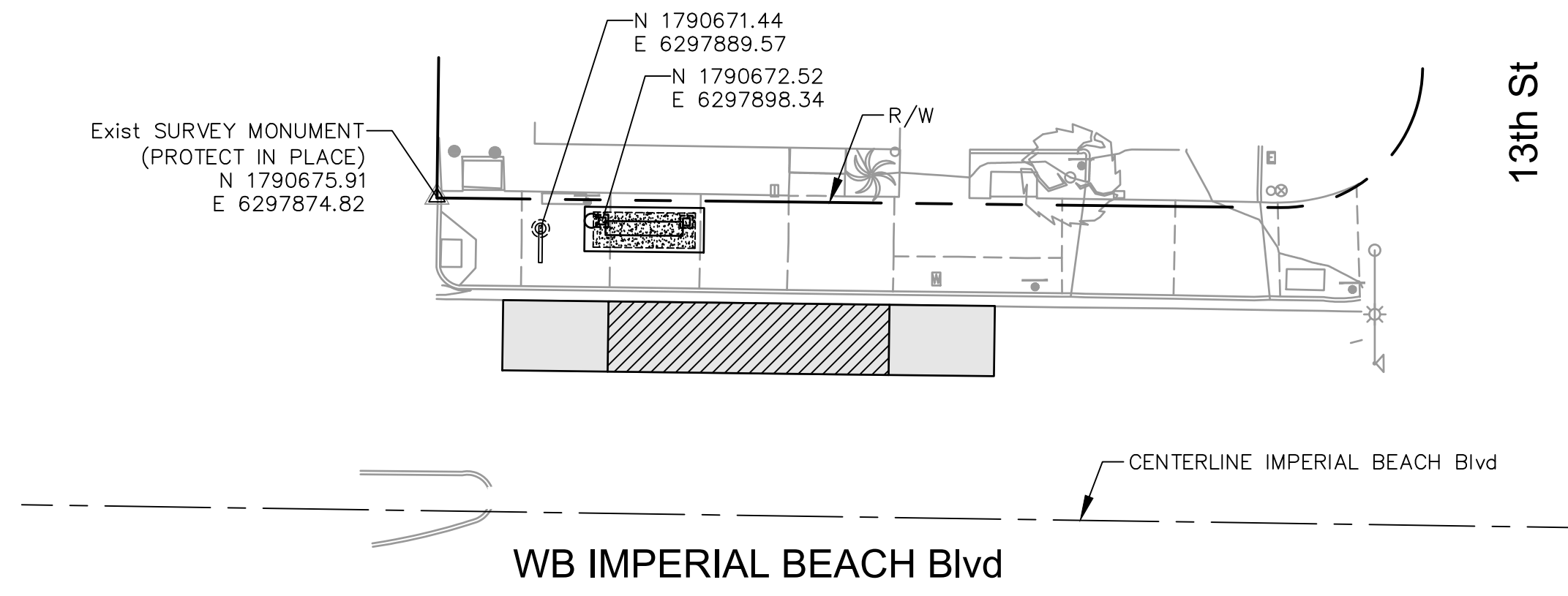

**SURVEY CONTROL POINT LOCATION**  
SCALE: 1" = 20'

PRIVATE CONTRACT

**IMPROVEMENT PLANS FOR:  
IRIS RAPID CORRIDOR  
AND STATION DESIGN  
IMPERIAL BEACH BLVD/CORONADO AVE**

CITY OF IMPERIAL BEACH, CALIFORNIA		PROJECT NO. XXXXXX
SHEET 12 OF 42 SHEETS		V.T.M.
DESCRIPTION	BY	APPROVED
		DATE
		FILMED
AS-BUILTS		
CONTRACTOR		DATE STARTED
INSPECTOR		DATE COMPLETED
		1786-6299 NAD83 COORDINATES
		146-1739 LAMBERT COORDINATES
		<b>12-D</b>

**NOTE:**

THE CITY OF SAN DIEGO ENGINEER DOES NOT CONSTITUTE APPROVAL OF THIS SHEET AS IT ONLY REFLECTS IMPROVEMENTS LOCATED WITHIN CITY OF IMPERIAL BEACH JURISDICTION.

**C.H. DONUTS**  
APN 626-542-11

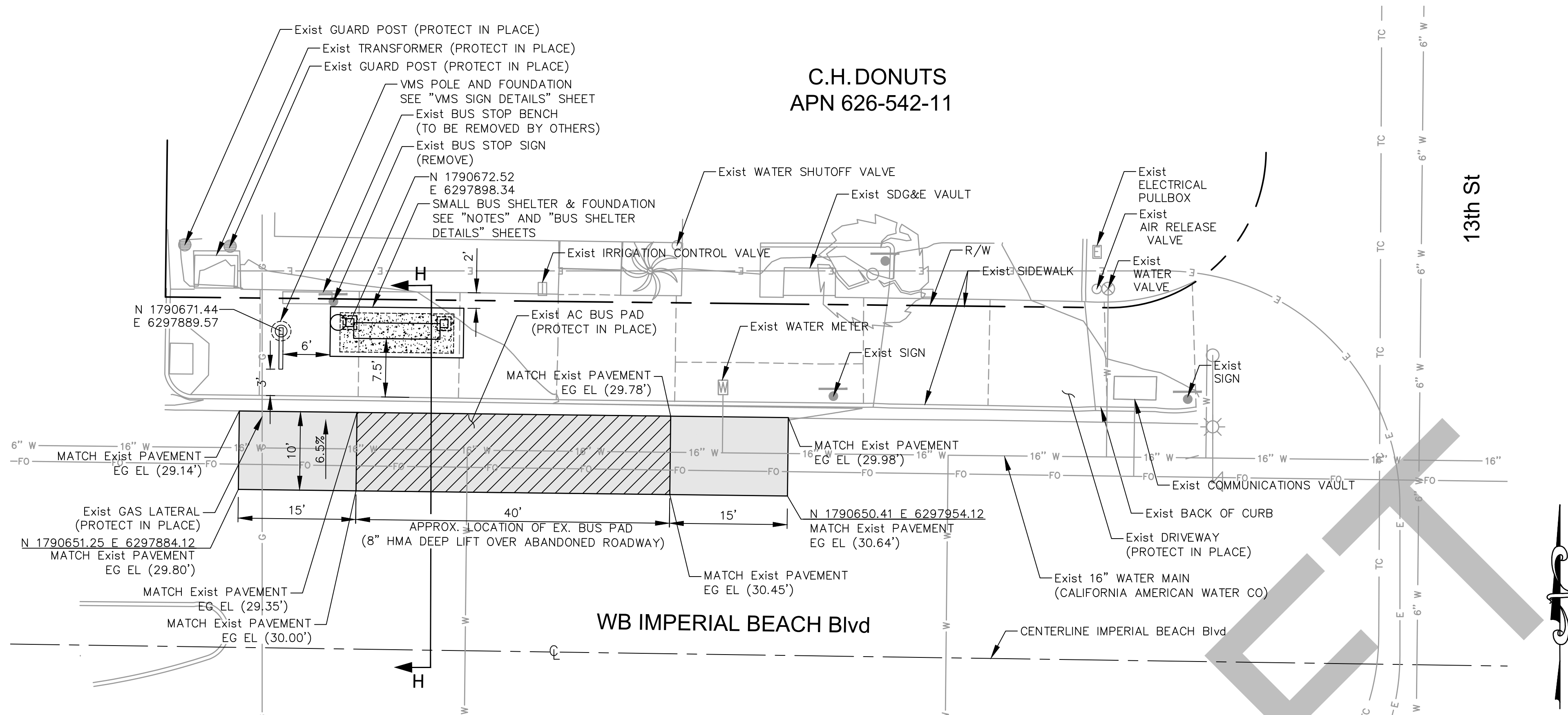

**PLAN**  
SCALE: 1" = 10'  
GRAPHIC SCALE

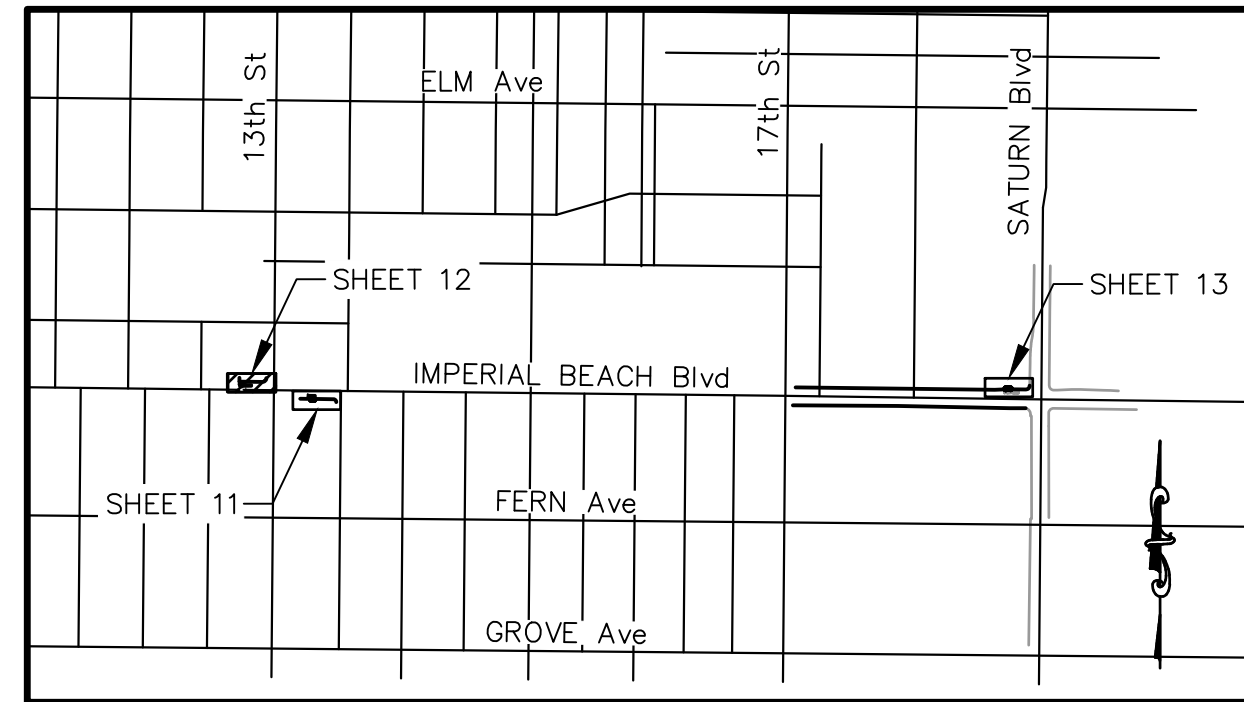

**KEYMAP**  
NOT TO SCALE

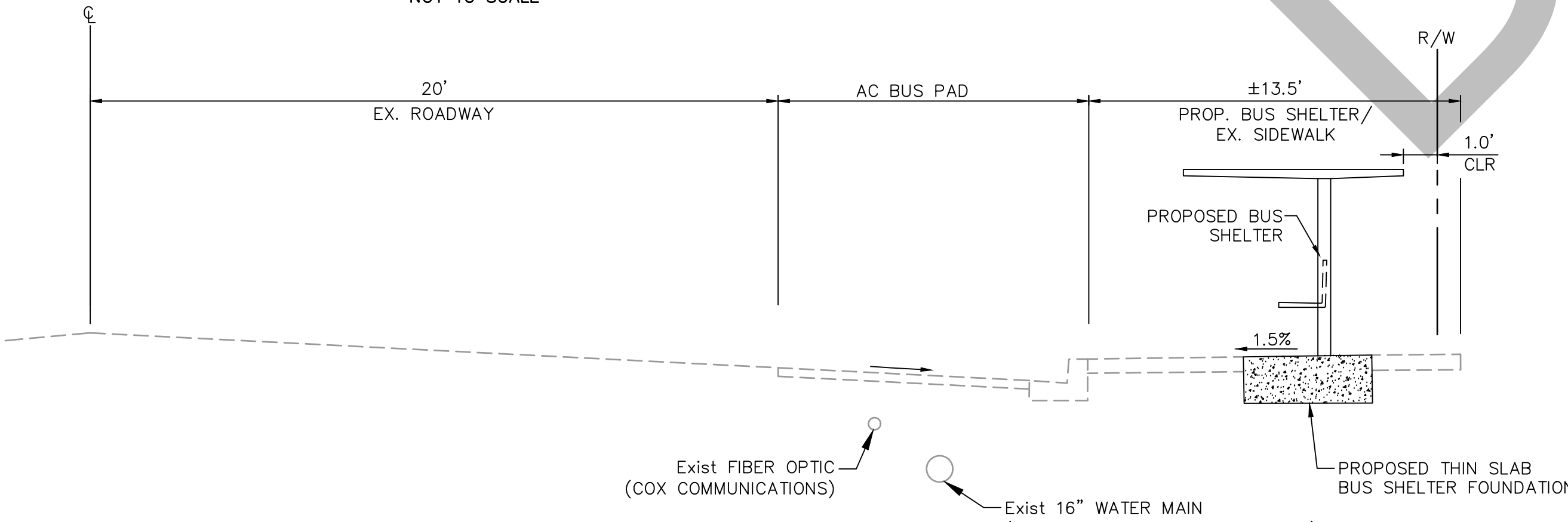

**SECTION H-H**  
NOT TO SCALE



*Mark Tarrall*  
MARK TARRALL R.C.E. NO. 71953 EXP. 12-31-23

DOKKEN ENGINEERING  
1450 FRAZEE ROAD, SUITE 100  
(858) 514-8377

DATE



### JACK IN THE BOX APN 627-302-32 LOT 5, MAP 7942

**\*\*EMRA NOTE:**  
THE MTS SMALL BUS SHELTER AND VMS POLE, PEDESTAL, AND SIGN PROPOSED WITHIN CITY OF SAN DIEGO PUBLIC RIGHT-OF-WAY ARE COVERED UNDER EMRA APPROVAL #2593913.

- NOTES:**
1. PROVIDE BUS SHELTER CLEARANCES PER SHEET 3 DIMENSIONS (UNLESS OTHERWISE NOTED).
  2. ALL ROADWAY STRIPING AFFECTED BY BUS PAD INSTALLATION SHALL BE REPLACED IN KIND.
  3. COORDINATE FURNITURE REMOVAL (BY OTHERS) WITH MTS.

- LEGEND:**
- Exist CONCRETE BUS PAD PER SDG-102
  - CONCRETE SIDEWALK PER SDG-155, 156 (1.5% MAX CROSS-SLOPE)
  - BUS SHELTER THIN SLAB FOUNDATION FOOTPRINT

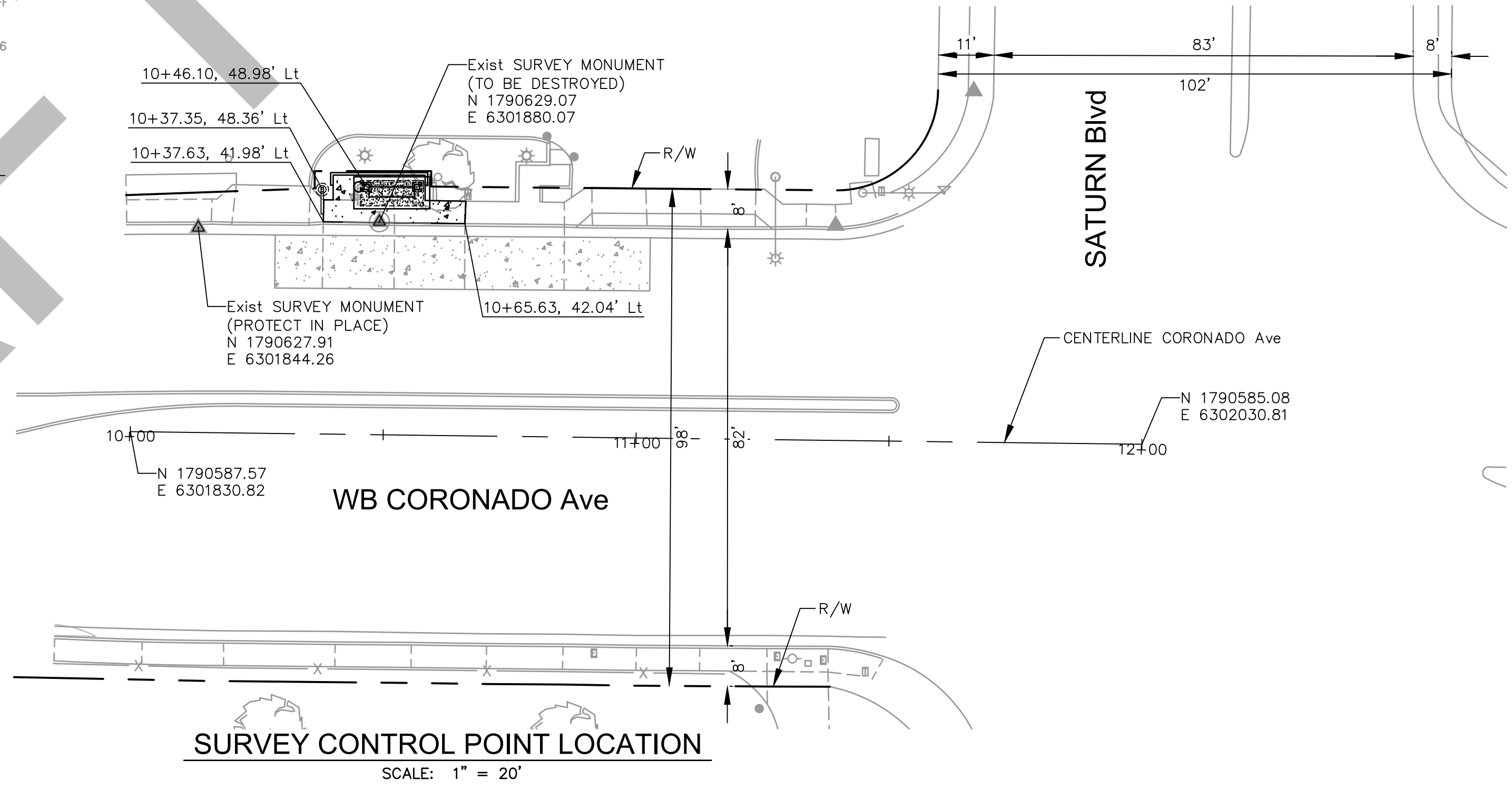
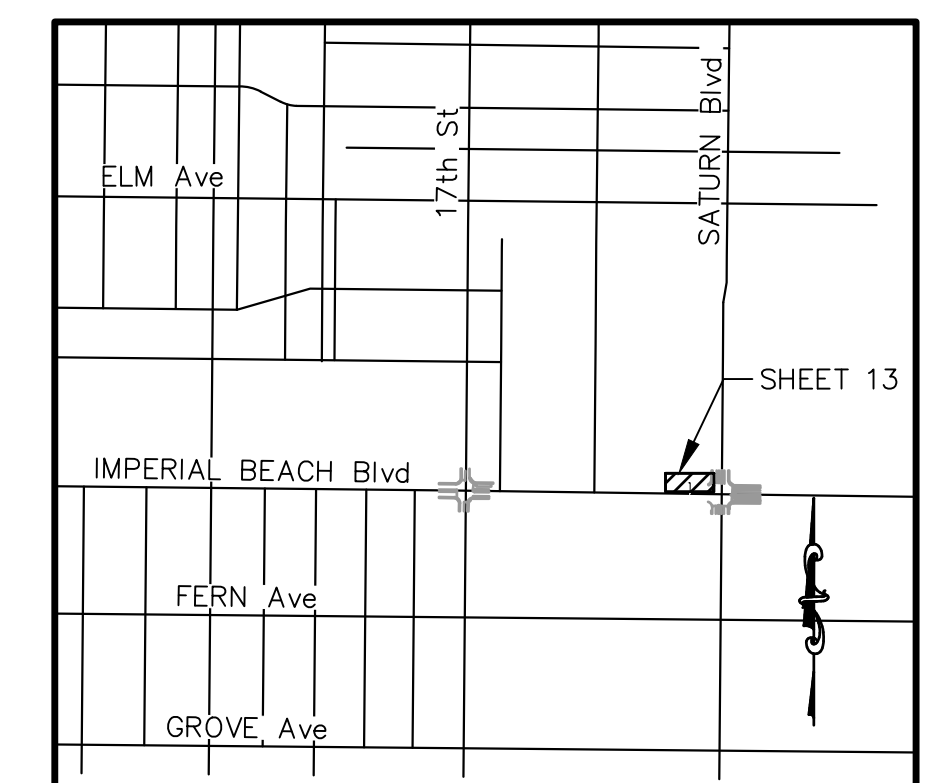
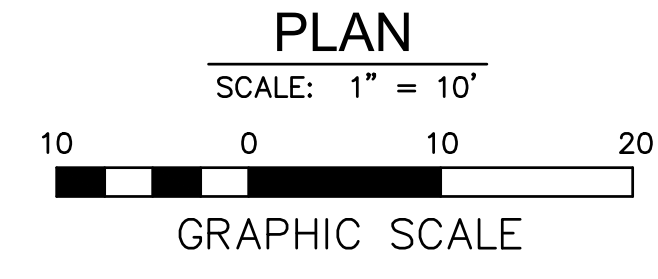
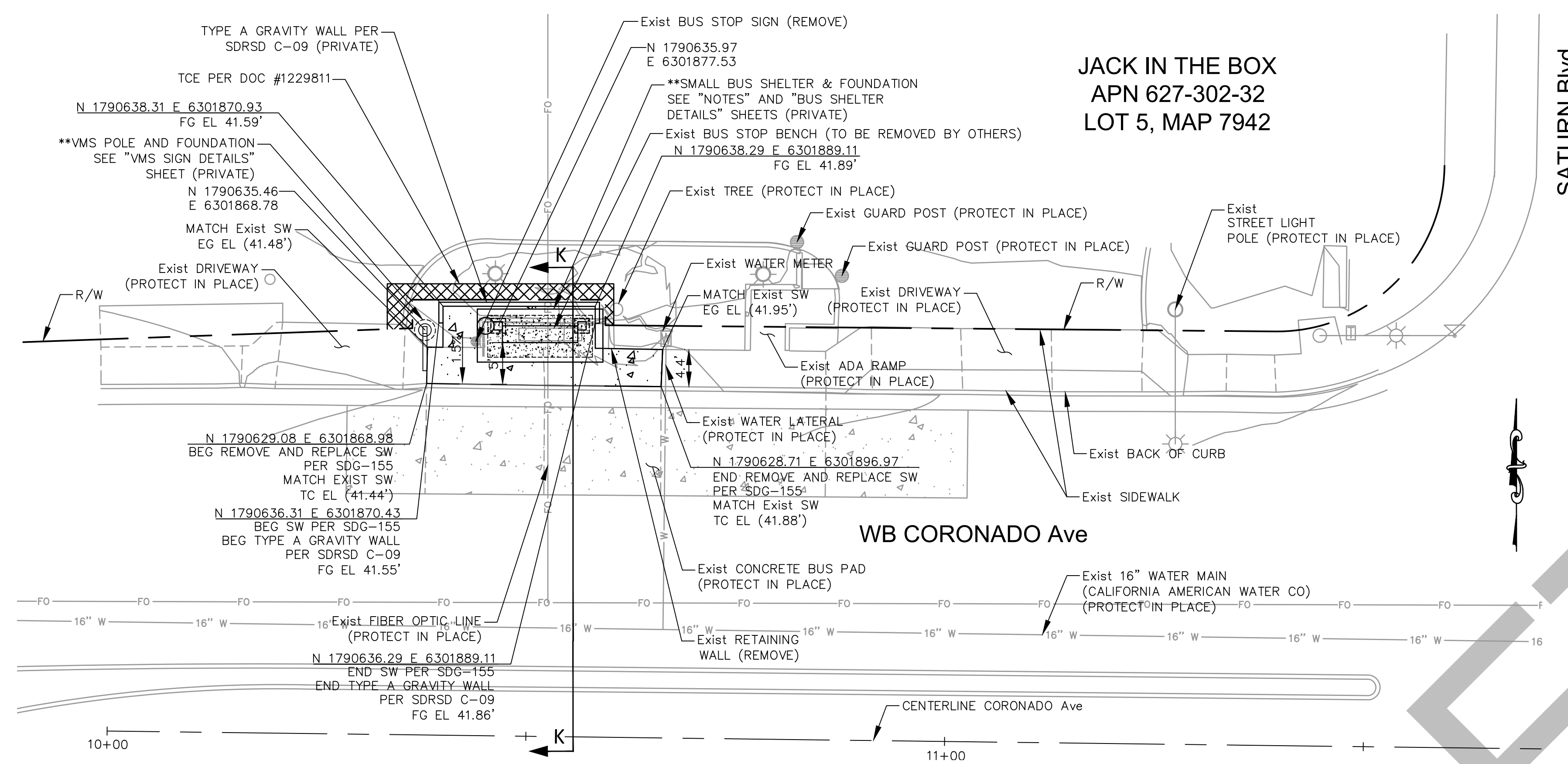

DRAFT

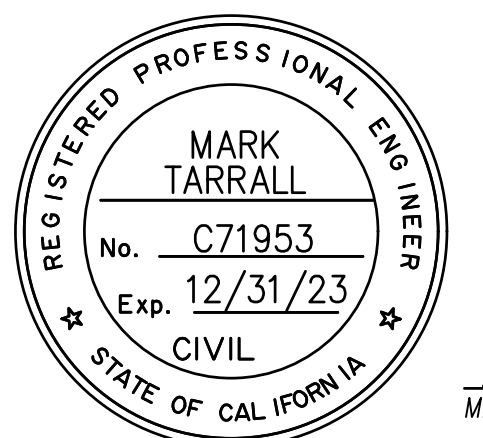
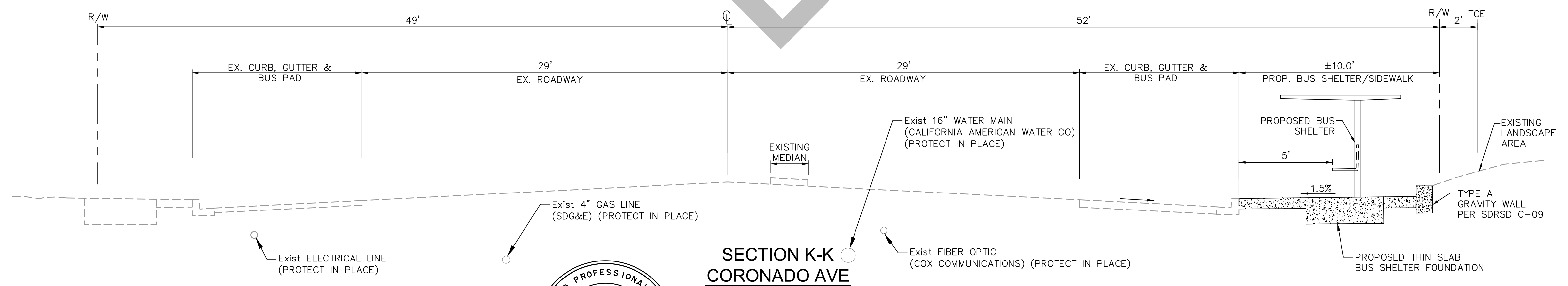

*Mark Tarrall*  
MARK TARRALL R.C.E. NO. 71953 EXP. 12-31-23

DOKKEN ENGINEERING  
1450 FRAZEE ROAD, SUITE 100  
(858) 514-8377

PRIVATE CONTRACT				PROJECT NO. XXXXXX	
<b>IMPROVEMENT PLANS FOR IRIS RAPID CORRIDOR AND STATION DESIGN IMPERIAL BEACH BLVD/CORONADO AVE</b>					
CITY OF SAN DIEGO, CALIFORNIA DEVELOPMENT SERVICES DEPARTMENT SHEET 33 OF 42 SHEETS				V.T.M.	
FOR CITY ENGINEER	DATE	APPROVED	DATE	FILMED	
DESCRIPTION	BY	APPROVED	DATE	FILMED	
AS-BUILTS					
CONTRACTOR	DATE STARTED				
INSPECTOR	DATE COMPLETED				
					<b>XXXXX-13-D</b>

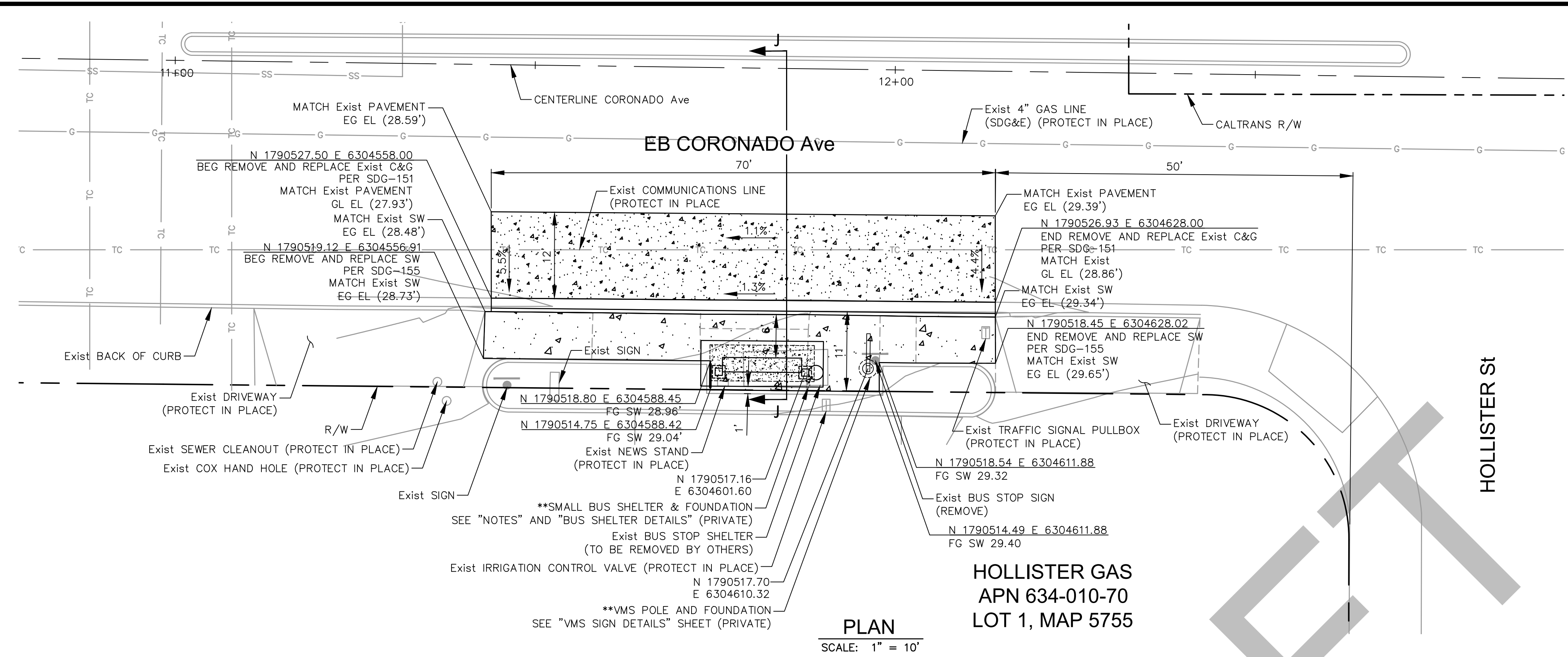

**\*\*EMRA NOTE:**  
 THE MTS SMALL BUS SHELTER AND MVS POLE, PEDESTAL, AND SIGN PROPOSED WITHIN CITY OF SAN DIEGO PUBLIC RIGHT-OF-WAY ARE COVERED UNDER EMRA APPROVAL #2593913.

- NOTES:**
1. PROVIDE BUS SHELTER CLEARANCES PER SHEET 3 DIMENSIONS (UNLESS OTHERWISE NOTED).
  2. ALL ROADWAY STRIPING AFFECTED BY BUS PAD INSTALLATION SHALL BE REPLACED IN KIND.
  3. ALL NEW CURB SHOULD BE PAINTED RED IN ORDER TO PREVENT PARKING ALONG THE PROPOSED BUS STOP LOCATION.
  4. COORDINATE FURNITURE REMOVAL (BY OTHERS) WITH MTS.

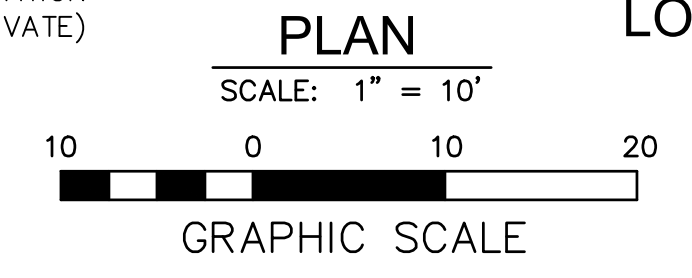
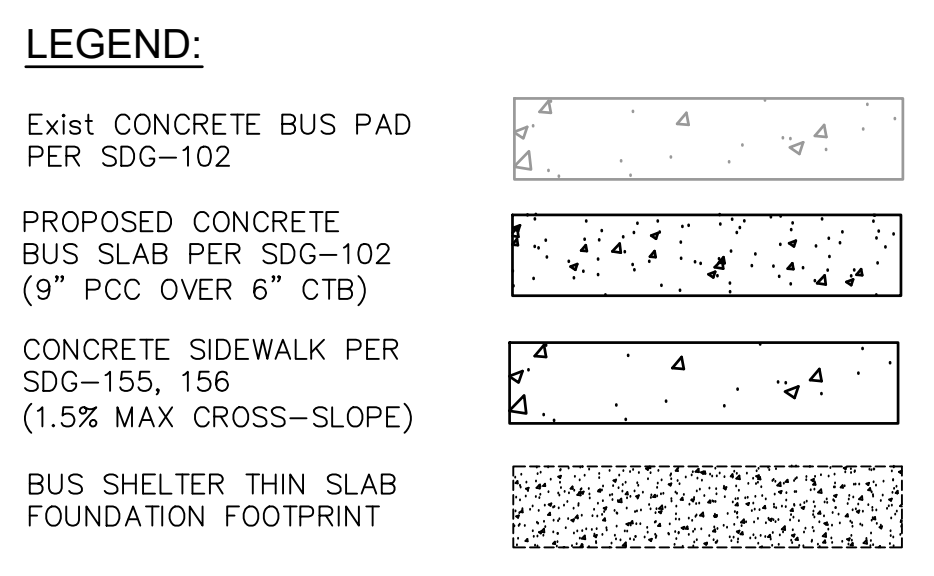

**HOLLISTER GAS**  
 APN 634-010-70  
 LOT 1, MAP 5755

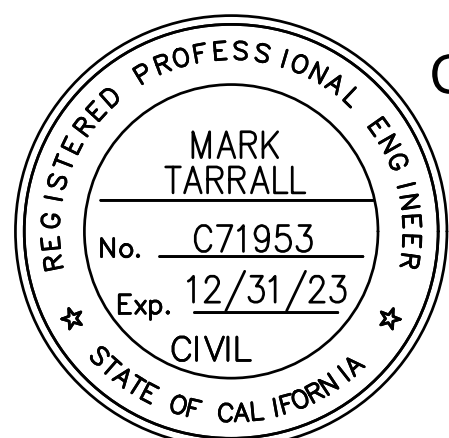
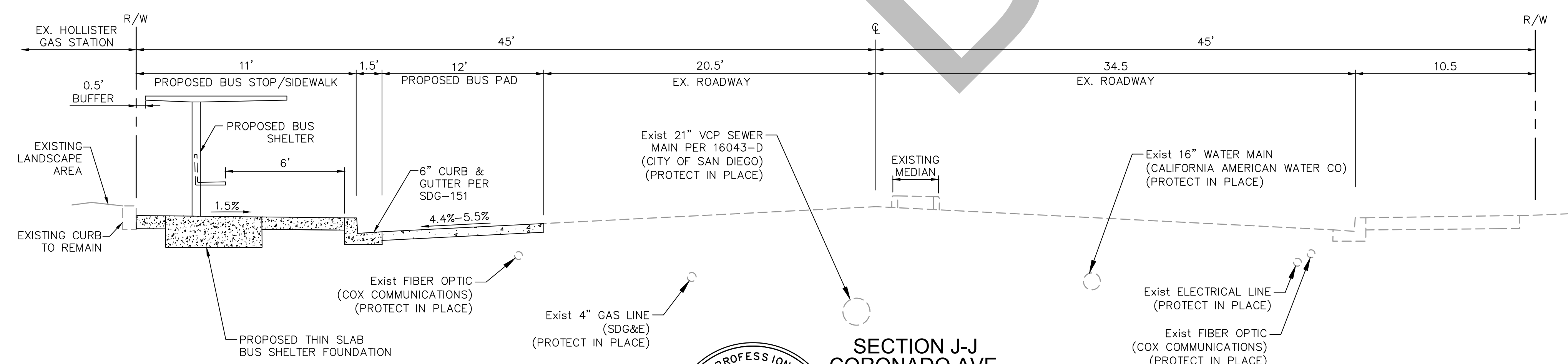
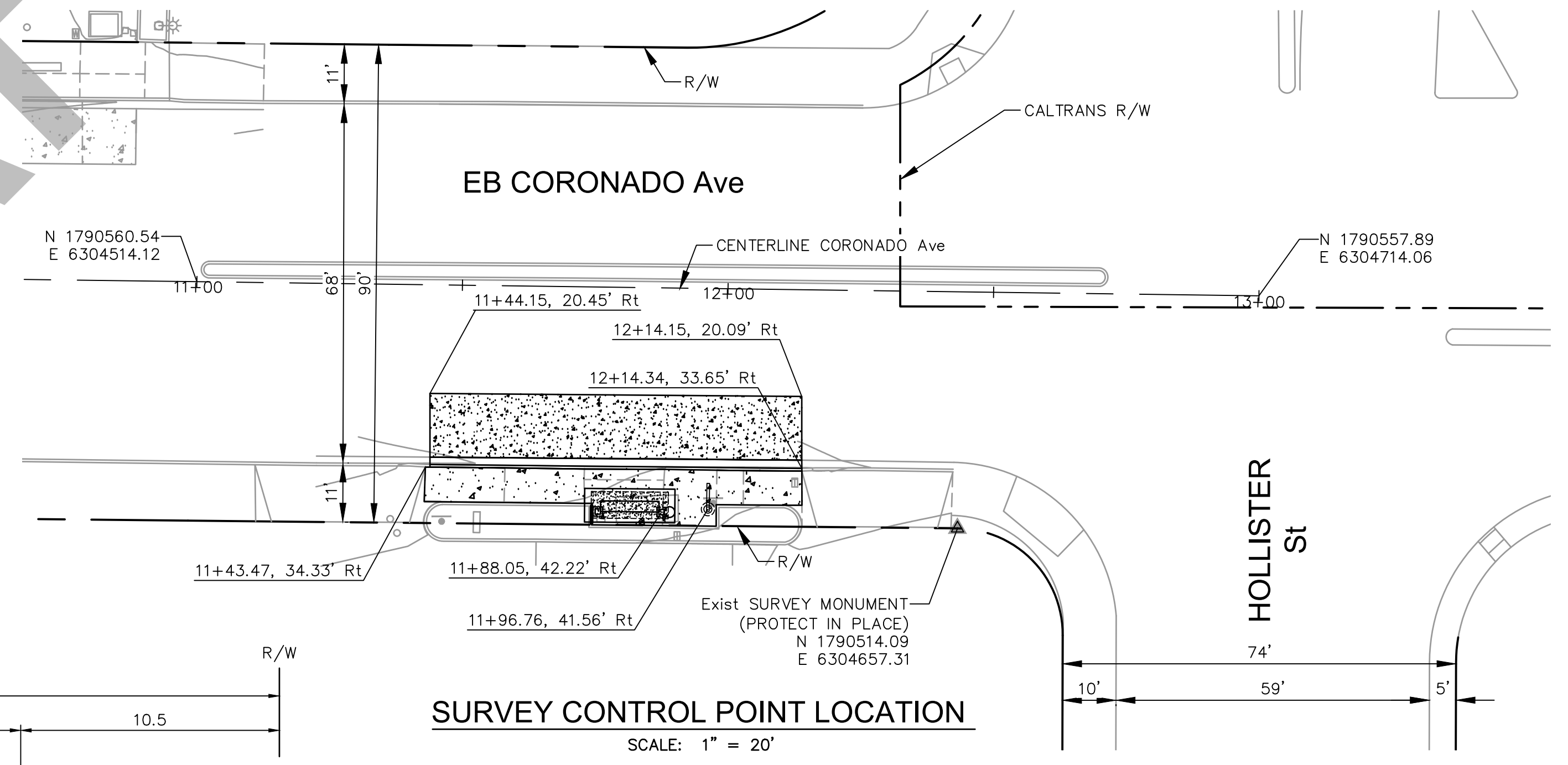
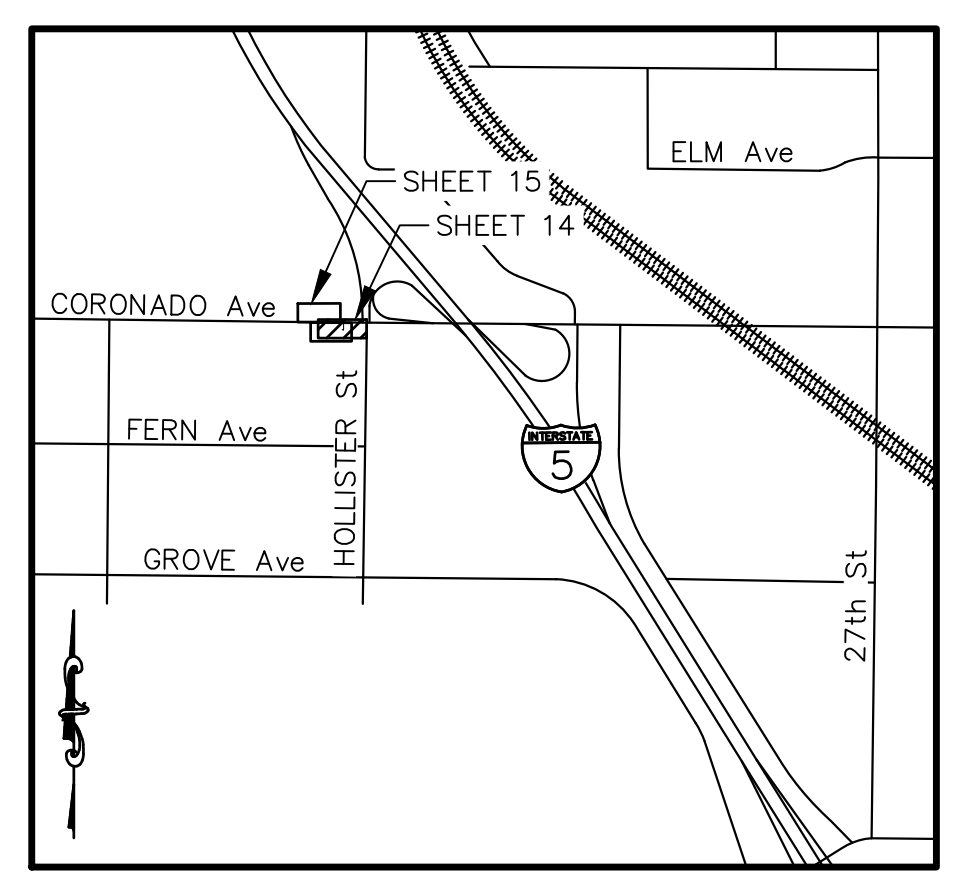

**SECTION J-J CORONADO AVE**  
 NOT TO SCALE

*Mark Tarrall*  
 MARK TARRALL R.C.E. NO. 71953 EXP. 12-31-23

DOKKEN ENGINEERING  
 1450 FRAZEE ROAD, SUITE 100  
 (858) 514-8377

PRIVATE CONTRACT

**IMPROVEMENT PLANS FOR IRIS RAPID CORRIDOR AND STATION DESIGN**  
 IMPERIAL BEACH BLVD/CORONADO AVE

CITY OF SAN DIEGO, CALIFORNIA DEVELOPMENT SERVICES DEPARTMENT SHEET 14 OF 42 SHEETS		PROJECT NO. XXXXXX
FOR CITY ENGINEER	DATE	V.T.M.
DESCRIPTION	BY	APPROVED
AS-BUILTS	DATE STARTED	DATE FILMED
CONTRACTOR	DATE STARTED	DATE COMPLETED
INSPECTOR	DATE STARTED	DATE COMPLETED

1790-6303  
 NAD83 COORDINATES  
 150-1743  
 LAMBERT COORDINATES  
**XXXX-14-D**

**DENNY'S PARKING LOT**  
**APN 628-110-18**  
**LOT 23, MAP 1768**

**\*\*EMRA NOTE:**  
 THE MTS SMALL BUS SHELTER AND MVS POLE, PEDESTAL, AND SIGN PROPOSED WITHIN CITY OF SAN DIEGO PUBLIC RIGHT-OF-WAY ARE COVERED UNDER EMRA APPROVAL #259391.

- NOTES:**
1. PROVIDE BUS SHELTER CLEARANCES PER SHEET 3 DIMENSIONS (UNLESS OTHERWISE NOTED).
  2. ALL ROADWAY STRIPING AFFECTED BY BUS PAD INSTALLATION SHALL BE REPLACED IN KIND.
  3. COORDINATE FURNITURE REMOVAL (BY OTHERS) WITH MTS.

**LEGEND:**

- Exist CONCRETE BUS PAD PER SDG-102
- PROPOSED CONCRETE BUS SLAB PER SDG-102 (9" PCC OVER 6" CTB)
- CONCRETE SIDEWALK PER SDG-155, 156 (1.5% MAX CROSS-SLOPE)
- BUS SHELTER THIN SLAB FOUNDATION FOOTPRINT

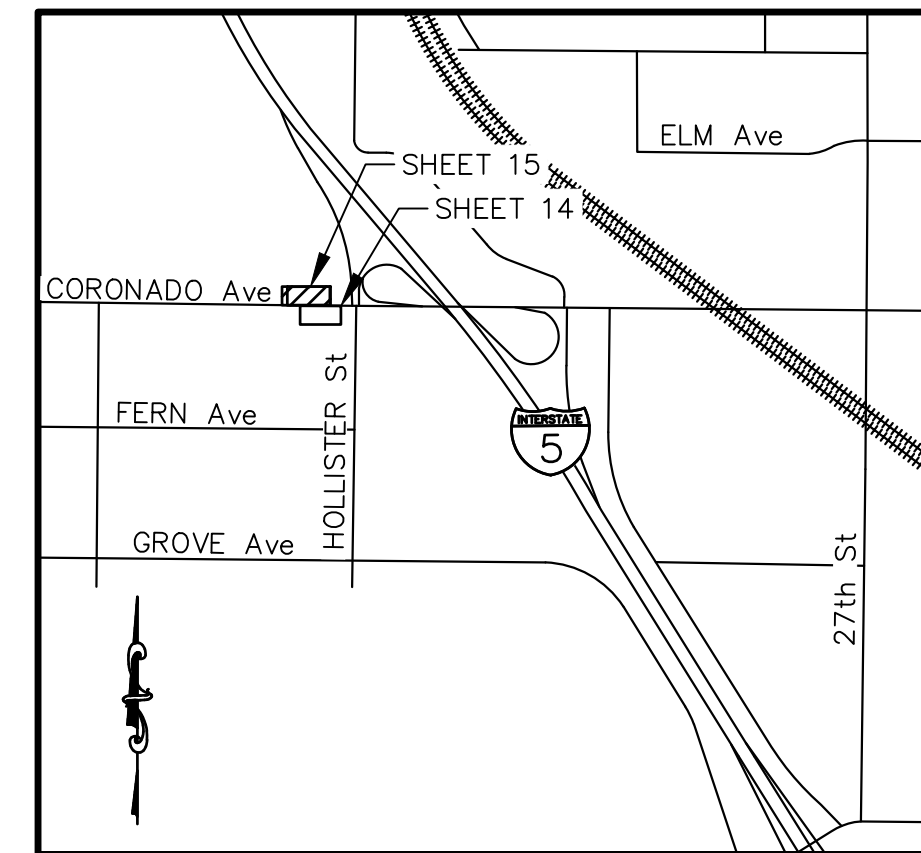
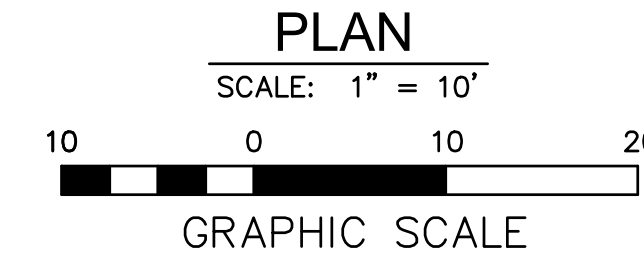
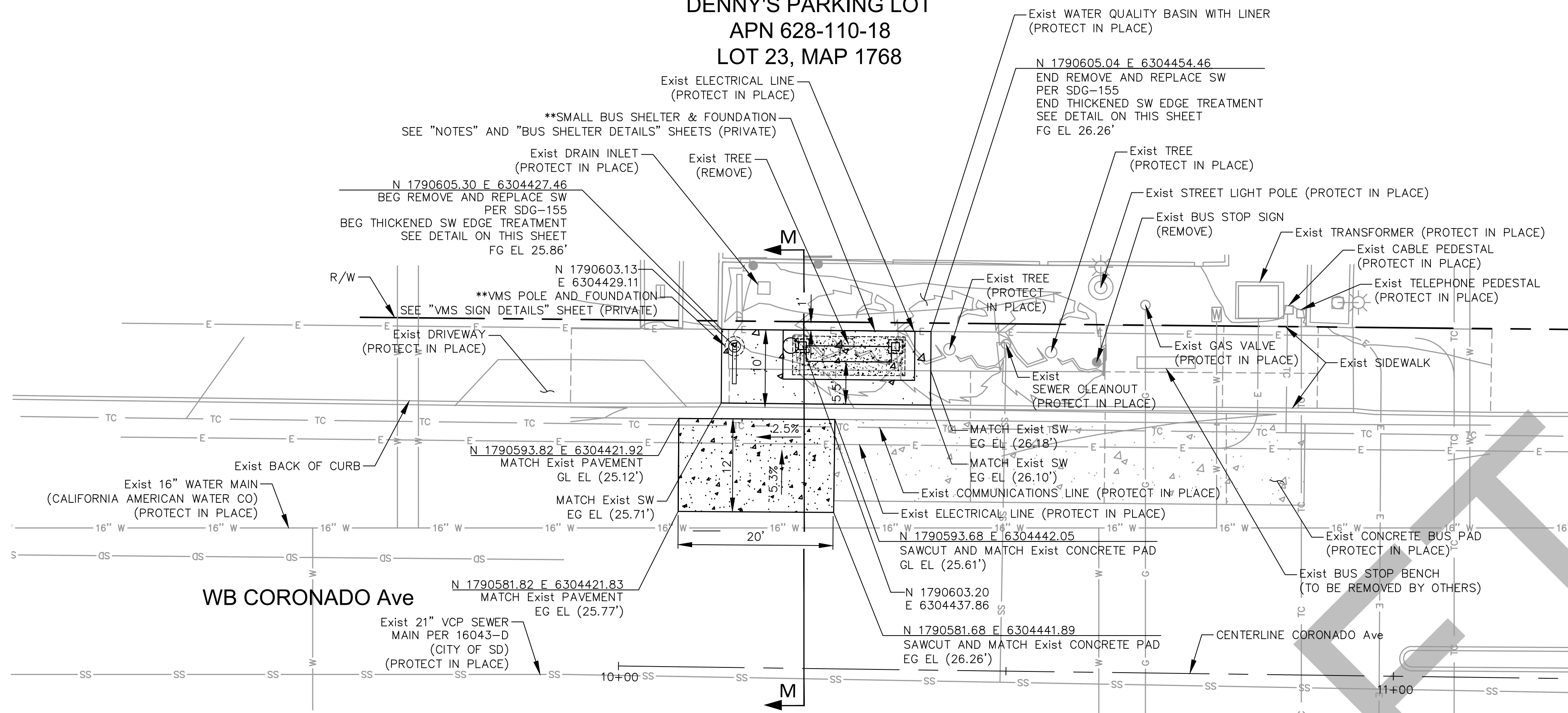

**KEYMAP**  
NOT TO SCALE

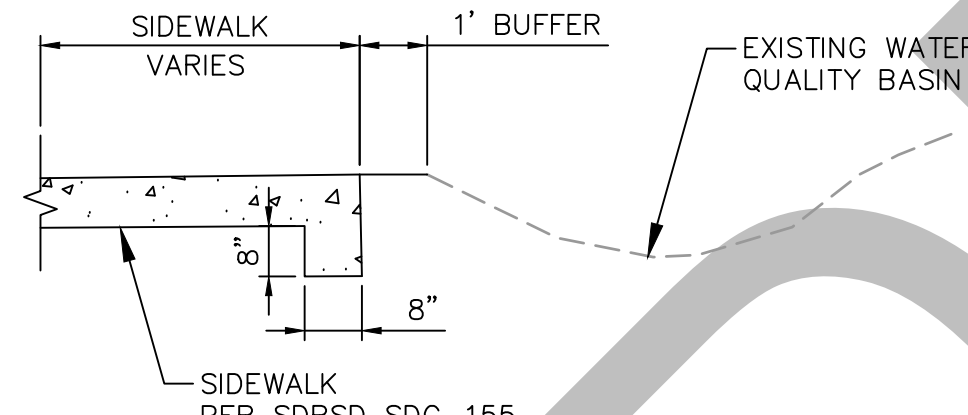

**THICKENED SIDEWALK EDGE TREATMENT**  
NOT TO SCALE

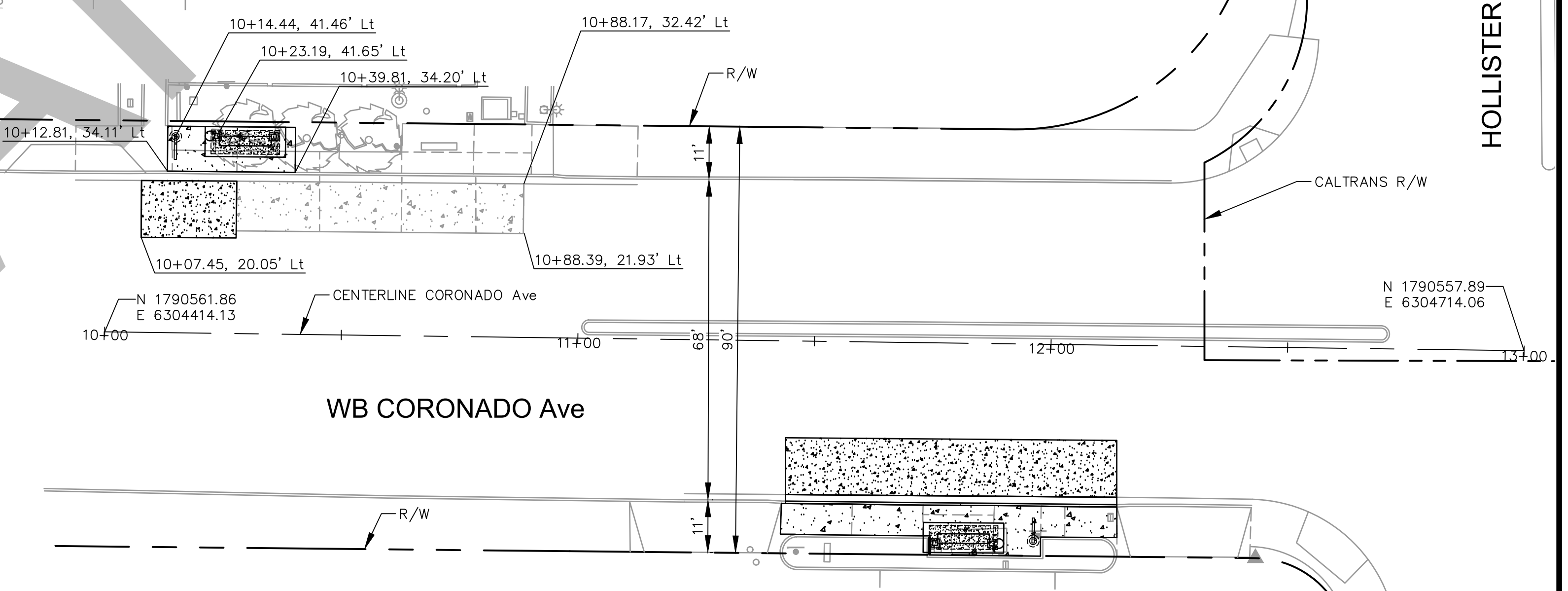

**SURVEY CONTROL POINT LOCATION**  
SCALE: 1" = 20'

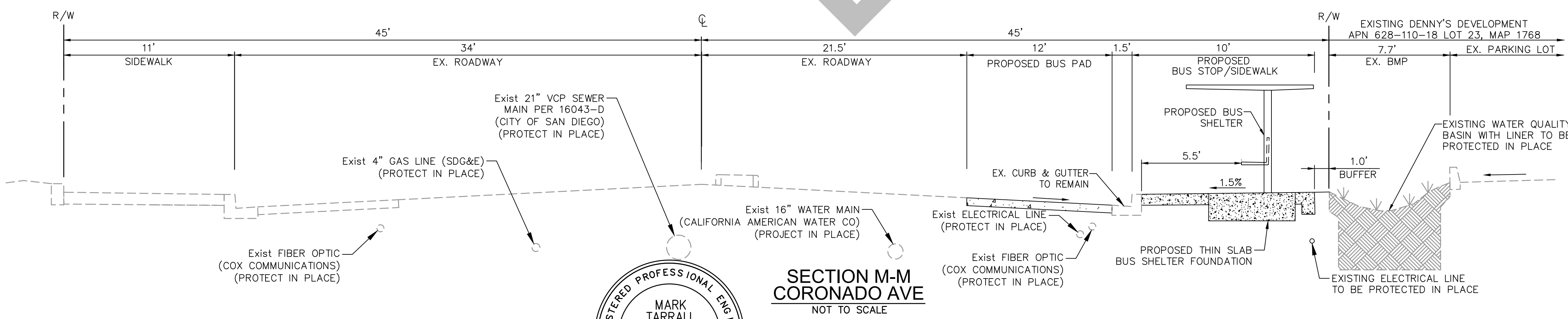

**SECTION M-M CORONADO AVE**  
NOT TO SCALE



*Mark Tarrall*  
 MARK TARRALL R.C.E. NO. 71953 EXP. 12-31-23

DOKKEN ENGINEERING  
 1450 FRAZEE ROAD, SUITE 100  
 (858) 514-8377

DATE

PRIVATE CONTRACT				
<b>IMPROVEMENT PLANS FOR IRIS RAPID CORRIDOR AND STATION DESIGN</b> IMPERIAL BEACH BLVD/CORONADO AVE				
CITY OF SAN DIEGO, CALIFORNIA DEVELOPMENT SERVICES DEPARTMENT SHEET 15 OF 42 SHEETS				PROJECT NO. XXXXXX
FOR CITY ENGINEER	DATE	APPROVED		V.T.M.
DESCRIPTION	BY	APPROVED	DATE	FILMED
AS-BUILTS				
CONTRACTOR	DATE STARTED			
INSPECTOR	DATE COMPLETED			
				1790-6303 NAD83 COORDINATES 150-1743 LAMBERT COORDINATES <b>XXXXX-15-D</b>

IRIS TRANSIT CENTER EAST  
APN 630-321-17  
LOT 11, MAP 9557

MTS LIMITS OF OPERATION

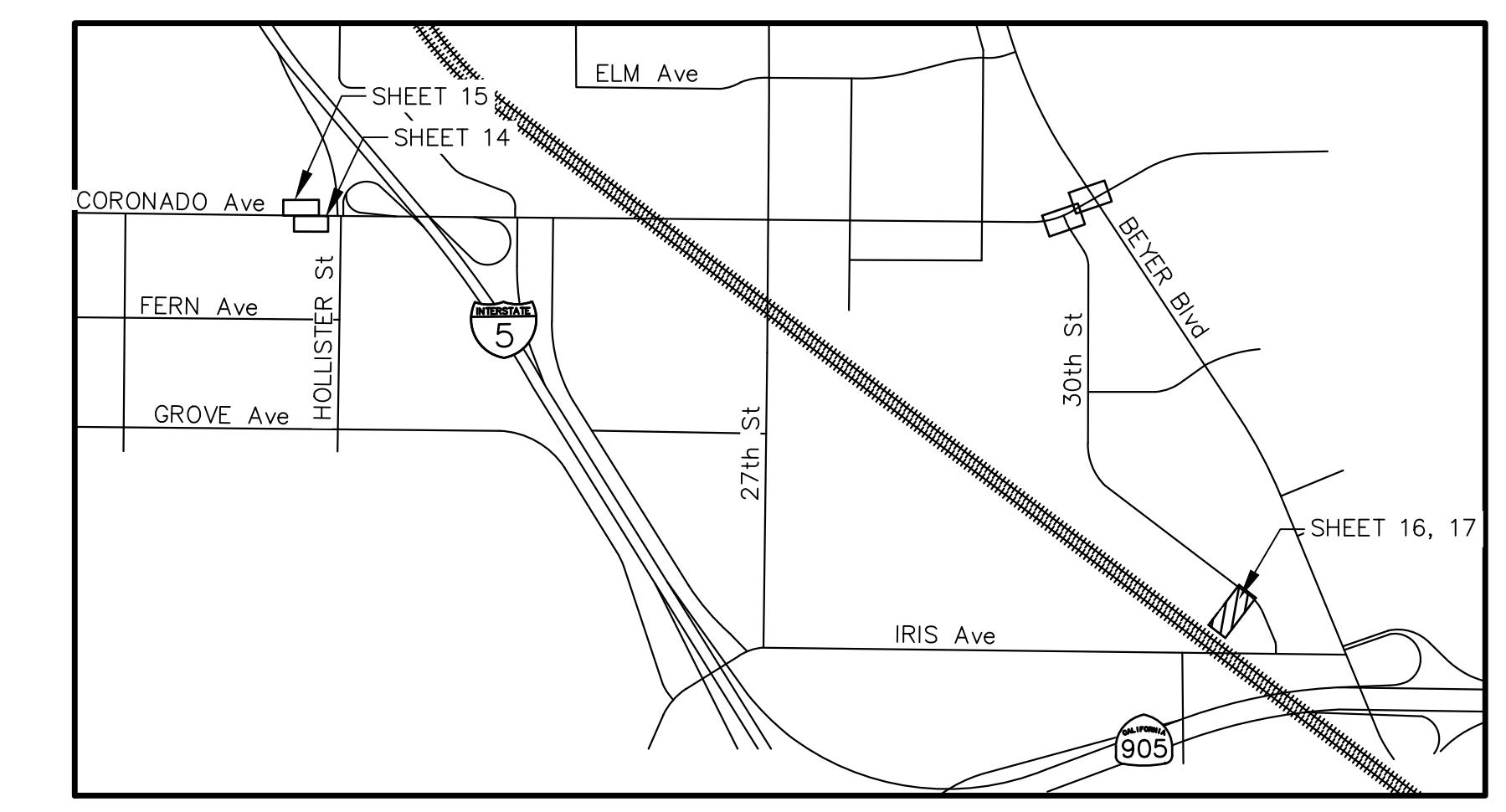
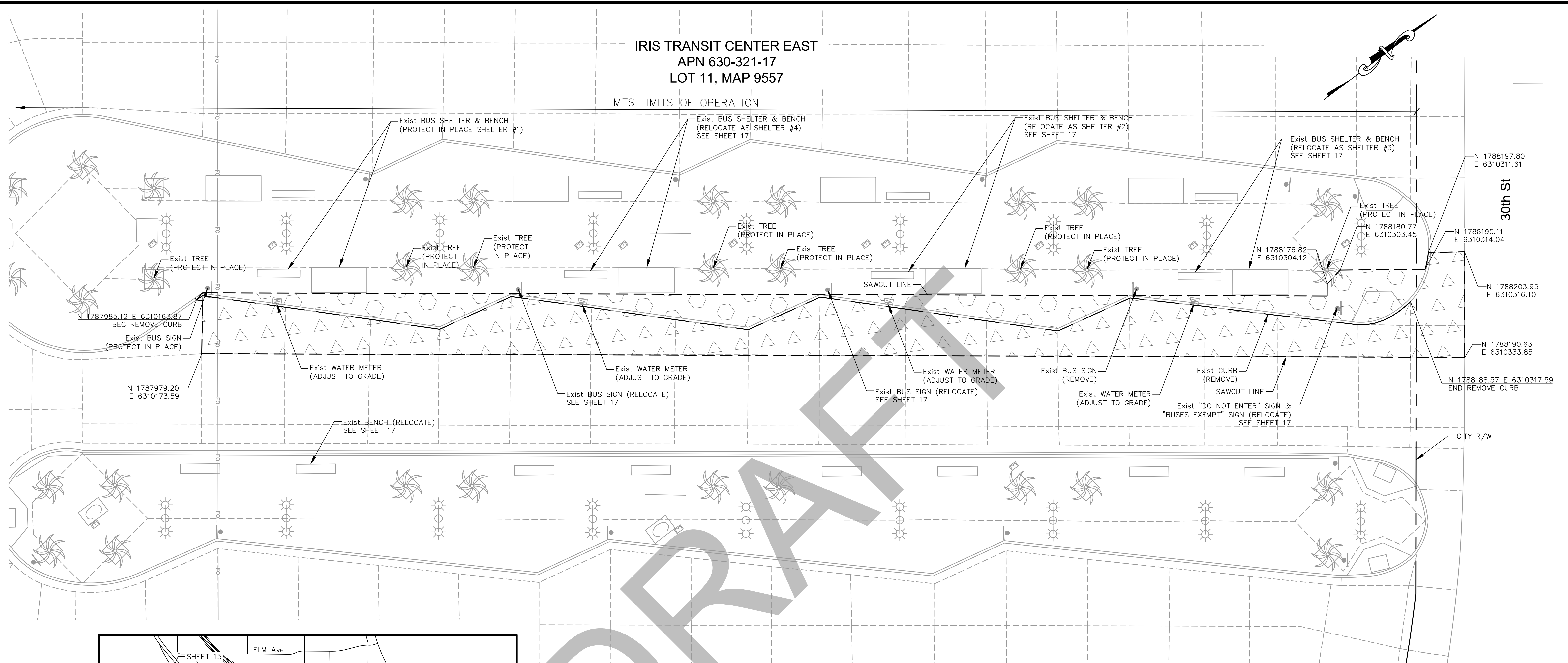

KEYMAP  
NOT TO SCALE

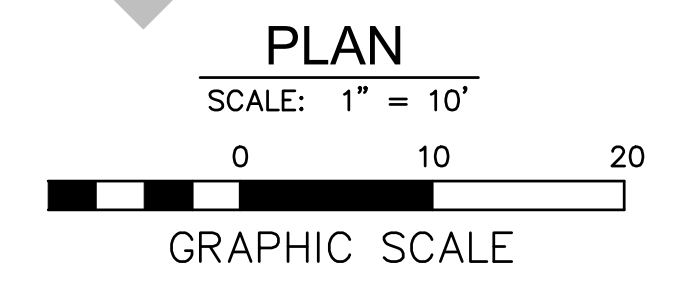

- LEGEND:**
- SAWCUT
  - REMOVE CURB / CURB AND GUTTER
  - REMOVE CONCRETE SIDEWALK
  - REMOVE CONCRETE PAVEMENT

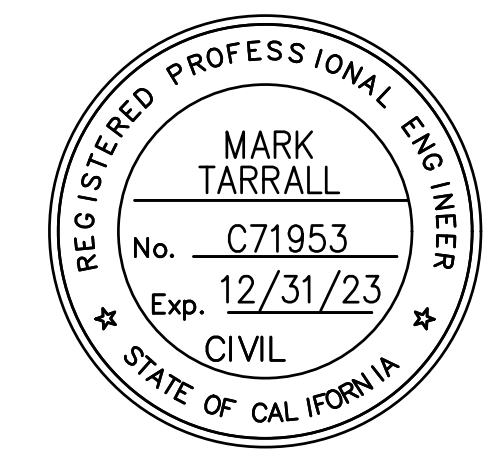

*Mark Tarrall*  
MARK TARRALL R.C.E. NO. 71953 EXP. 12-31-23

DOKKEN ENGINEERING  
1450 FRAZEE ROAD, SUITE 100  
(858) 514-8377

DATE

PRIVATE CONTRACT				
<b>DEMOLITION PLANS FOR IRIS RAPID CORRIDOR AND STATION DESIGN IRIS AVENUE TRANSIT CENTER EAST</b>				
CITY OF SAN DIEGO, CALIFORNIA DEVELOPMENT SERVICES DEPARTMENT SHEET 16 OF 42 SHEETS				PROJECT NO. XXXXXX
FOR CITY ENGINEER		DATE		V.T.M.
DESCRIPTION	BY	APPROVED	DATE	FILMED
AS-BUILTS				
CONTRACTOR		DATE STARTED		
INSPECTOR		DATE COMPLETED		
				<b>XXXXX-16-D</b>



IRIS TRANSIT CENTER EAST  
 APN 630-321-17  
 LOT 11, MAP 9557

MTS LIMITS OF OPERATION

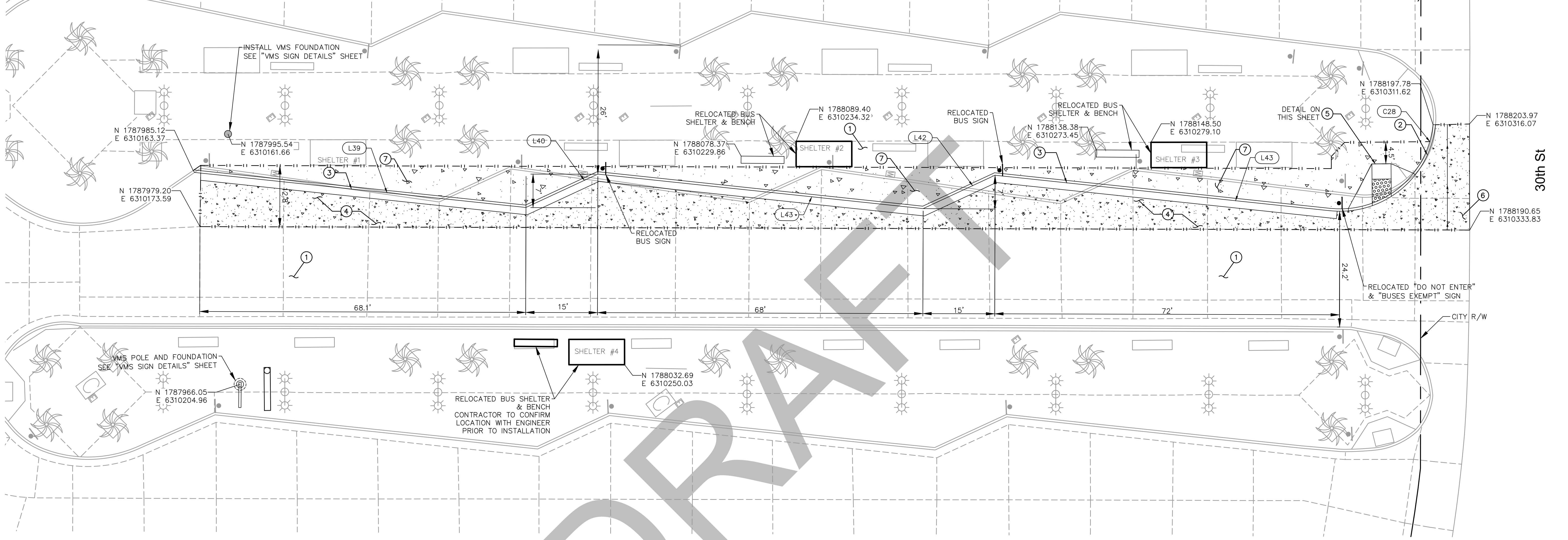

30th St

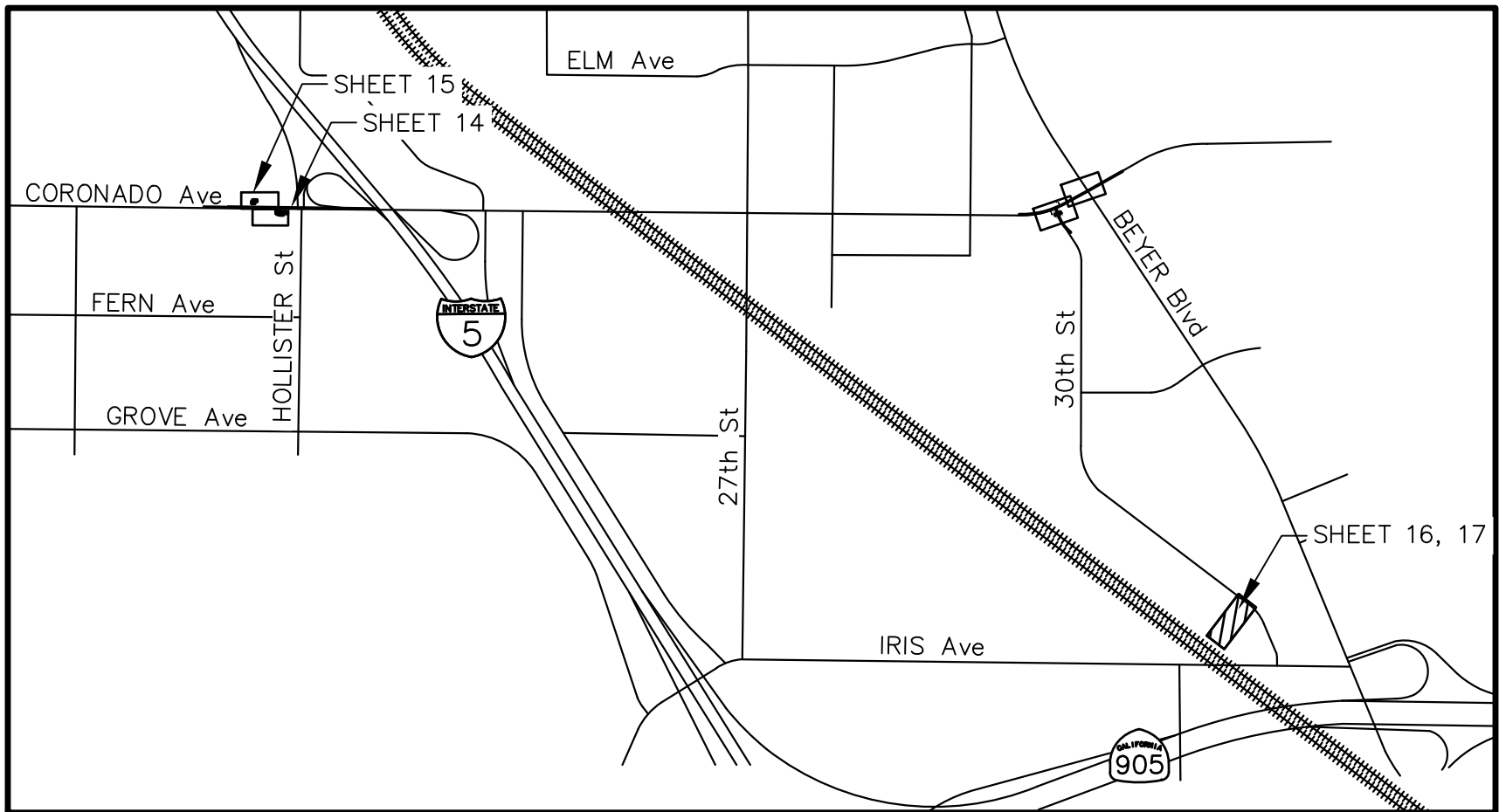

KEYMAP  
 NOT TO SCALE

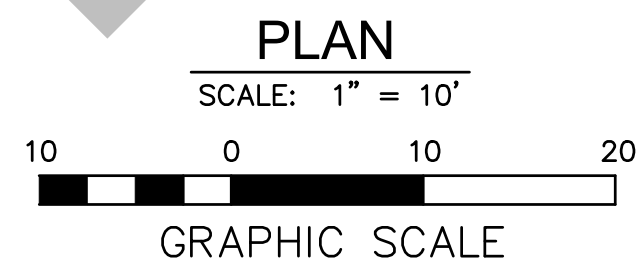

CONSTRUCTION NOTES

- ① PROTECT EXISTING PCC (PVT.)
- ② 6" CURB PER SDG-150 (PVT.)
- ③ 6" CURB & GUTTER PER SDG-151 (PVT.)
- ④ 7.5" PORTLAND CEMENT CONCRETE OVER 12" CRUSHED AGGREGATE BASE OVER 12" COMPACTED SUBGRADE PER GEOTECHNICAL RECOMMENDATIONS (PVT.)
- ⑤ TYPE A CURB RAMP PER SDG-132 (PVT.)
- ⑥ INSTALL 10'-FT WIDE CROSS GUTTER PER SDG-157
- ⑦ INSTALL CONCRETE SIDEWALK PER SDG-155 & SDG-156 (PVT.) (1.5% MAX CROSS-SLOPE)

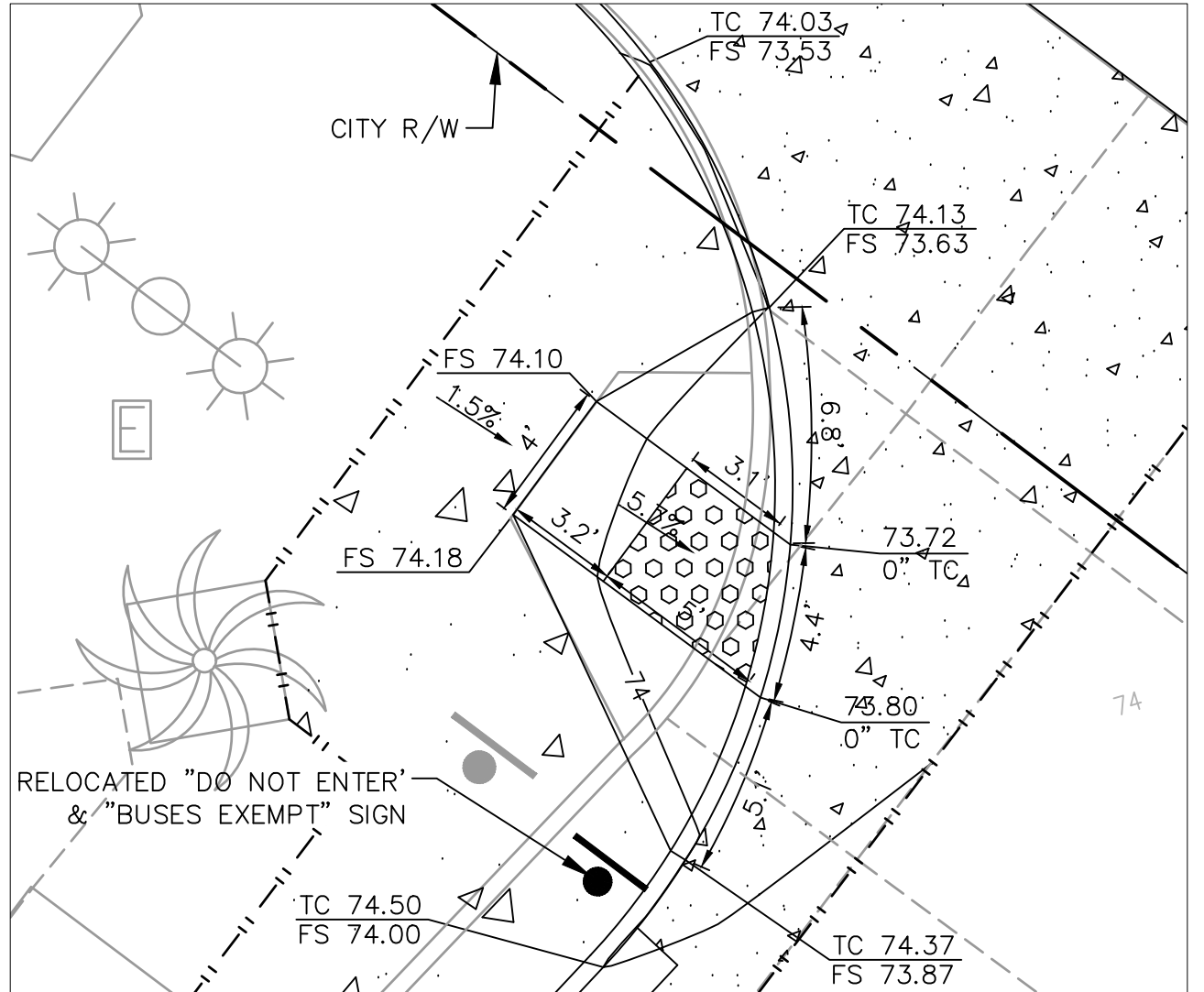

PLAN: CURB RAMP  
 SCALE: 1" = 5'  
 (TYPE A CURB RAMP SDG-132)  
 (PRIVATE IMPROVEMENTS)

LINE AND CURVE TABLE				
NUMBER	BEARING/Delta	RADIUS	LENGTH	REMARKS
L39	N43°02'20"E		69.62'	6" CURB & GUTTER PER SDG-151
L40	N12°08'40"E		16.55'	6" CURB & GUTTER PER SDG-151
L41	N43°02'20"E		68.34'	6" CURB & GUTTER PER SDG-151
L42	N12°08'40"E		16.55'	6" CURB & GUTTER PER SDG-151
L43	N43°02'20"E		70.39'	6" CURB & GUTTER PER SDG-151
C28	90.56	20.00'	31.61'	6" CURB PER SDG-150



*M. Blawell*  
 MARK TARRALL R.C.E. NO. 71953 EXP. 12-31-23

DOKKEN ENGINEERING  
 1450 FRAZEE ROAD, SUITE 100  
 (858) 514-8377

DATE

PRIVATE CONTRACT

**IMPROVEMENT PLANS FOR IRIS RAPID CORRIDOR AND STATION DESIGN**  
 IRIS AVENUE TRANSIT CENTER EAST

CITY OF SAN DIEGO, CALIFORNIA  
 DEVELOPMENT SERVICES DEPARTMENT  
 SHEET 17 OF 42 SHEETS

PROJECT NO. XXXXXX

FOR CITY ENGINEER: \_\_\_\_\_ DATE: \_\_\_\_\_ V.T.M. \_\_\_\_\_

DESCRIPTION	BY	APPROVED	DATE	FILMED

AS-BUILTS \_\_\_\_\_

CONTRACTOR \_\_\_\_\_ DATE STARTED \_\_\_\_\_

INSPECTOR \_\_\_\_\_ DATE COMPLETED \_\_\_\_\_

1786-6307  
 NAD83 COORDINATES  
 146-1747  
 LAMBERT COORDINATES

XXXXX-17-D

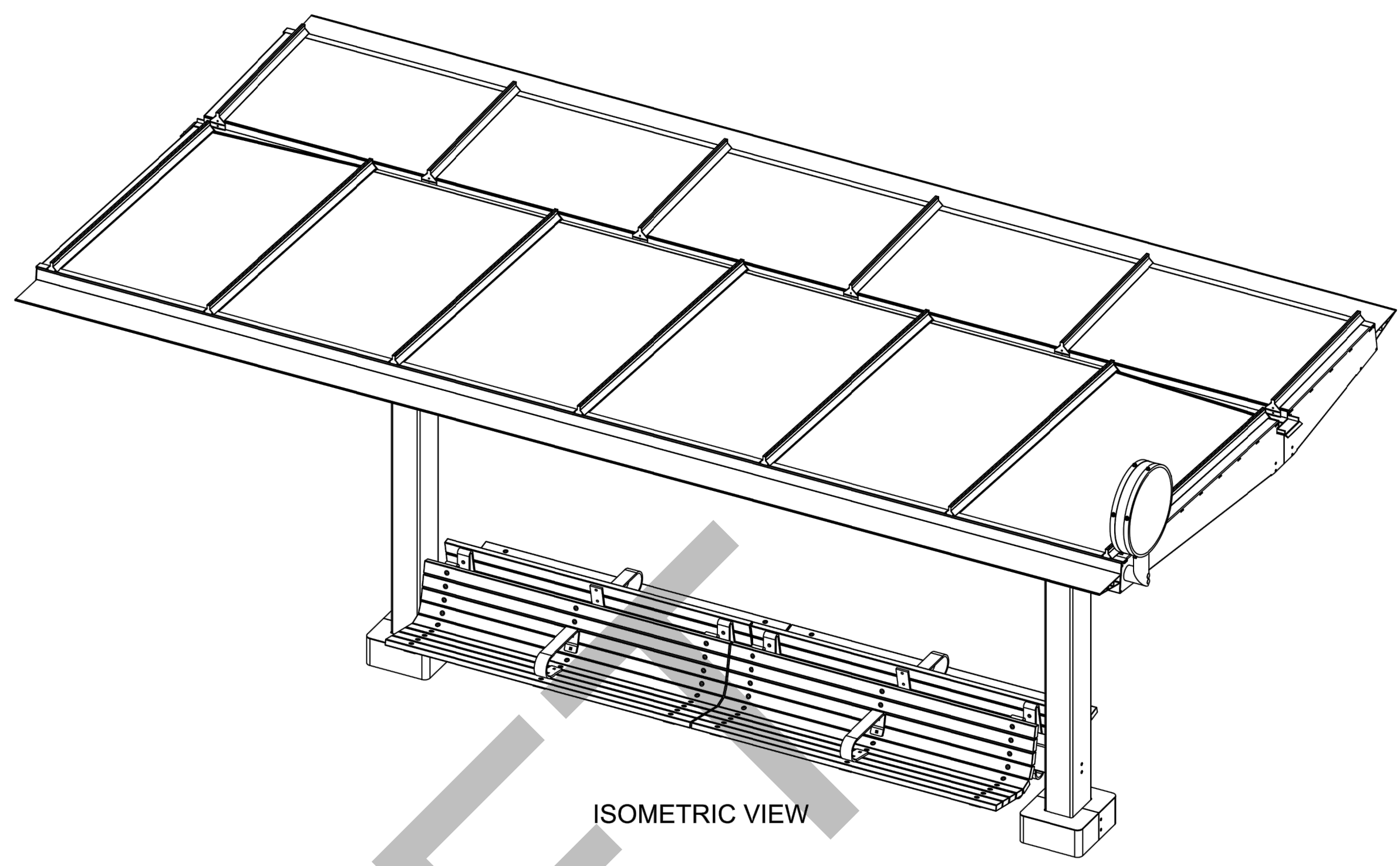
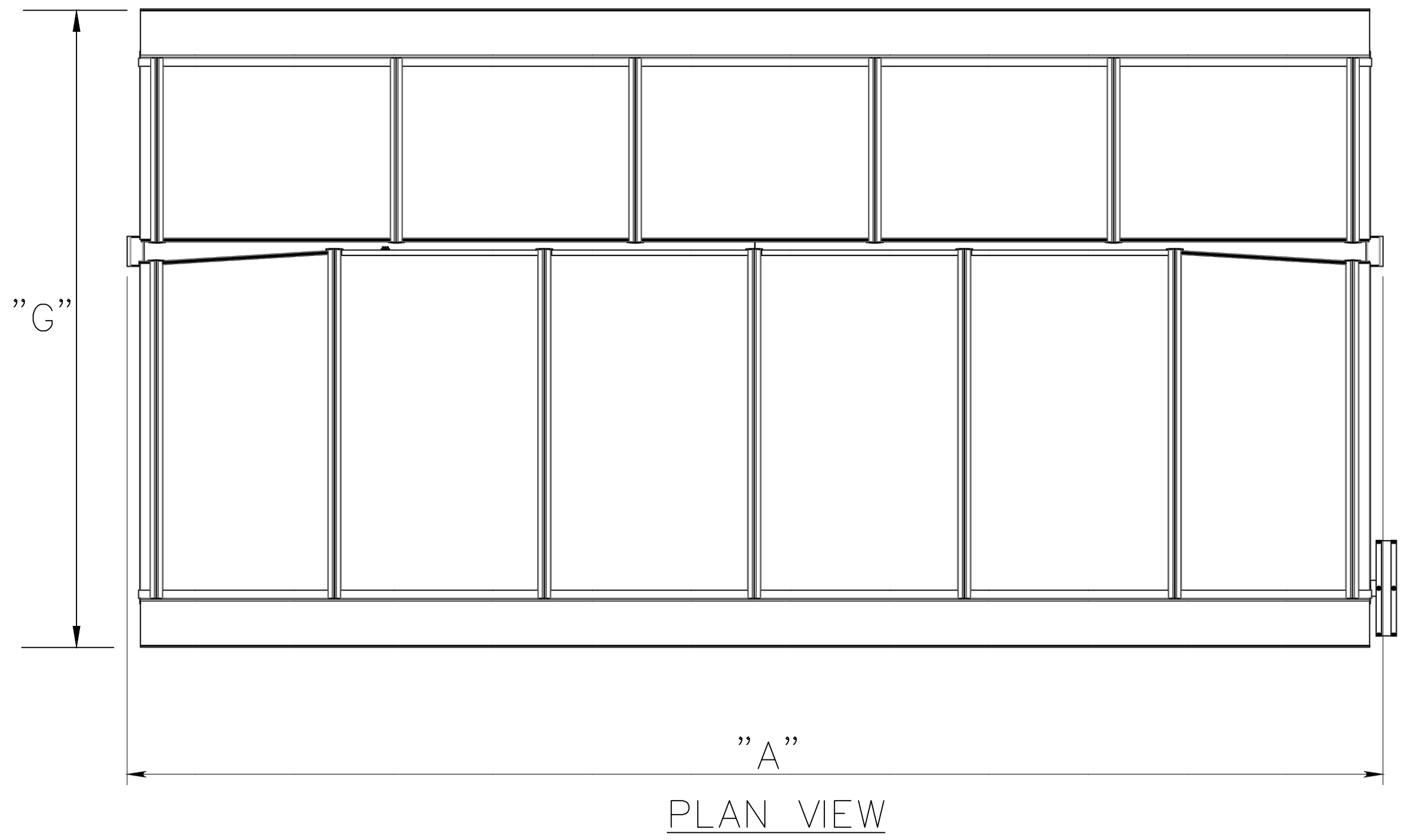

DIMENSION TABLE

	WB IMPERIAL AT 3RD ST.	EB IMPERIAL AT SHERIFF STATION	WB IMPERIAL AT VETERANS PARK
A	17.00'	17.00'	17.00'
B	14.60'	14.60'	14.60'
C	12.00'	12.00'	12.00'
D	2.50'	2.50'	2.50'
E	8.40'	8.40'	8.40'
F	9.05'	9.05'	9.05'
G	6.33'	6.33'	6.33'
H	4.33'	4.33'	4.33'

DIMENSION TABLE

	EB IMPERIAL AT 13TH ST.	WB IMPERIAL AT 13TH ST.	EB CORONADO AT SATURN
A	15.00'	17.00'	17.00'
B	12.60'	14.60'	14.60'
C	10.00'	12.00'	12.00'
D	2.50'	2.50'	2.50'
E	8.40'	8.40'	8.40'
F	9.05'	9.05'	9.05'
G	6.33'	6.33'	6.33'
H	4.33'	4.33'	4.33'

DIMENSION TABLE

	WB CORONADO AT SATURN	EB CORONADO AT HOLLISTER	WB CORONADO AT HOLLISTER
A	15.00'	17.00'	17.00'
B	12.60'	14.60'	14.60'
C	10.00'	12.00'	12.00'
D	2.50'	2.50'	2.50'
E	8.40'	8.40'	8.40'
F	9.05'	9.05'	9.05'
G	6.33'	6.33'	6.33'
H	4.33'	4.33'	4.33'

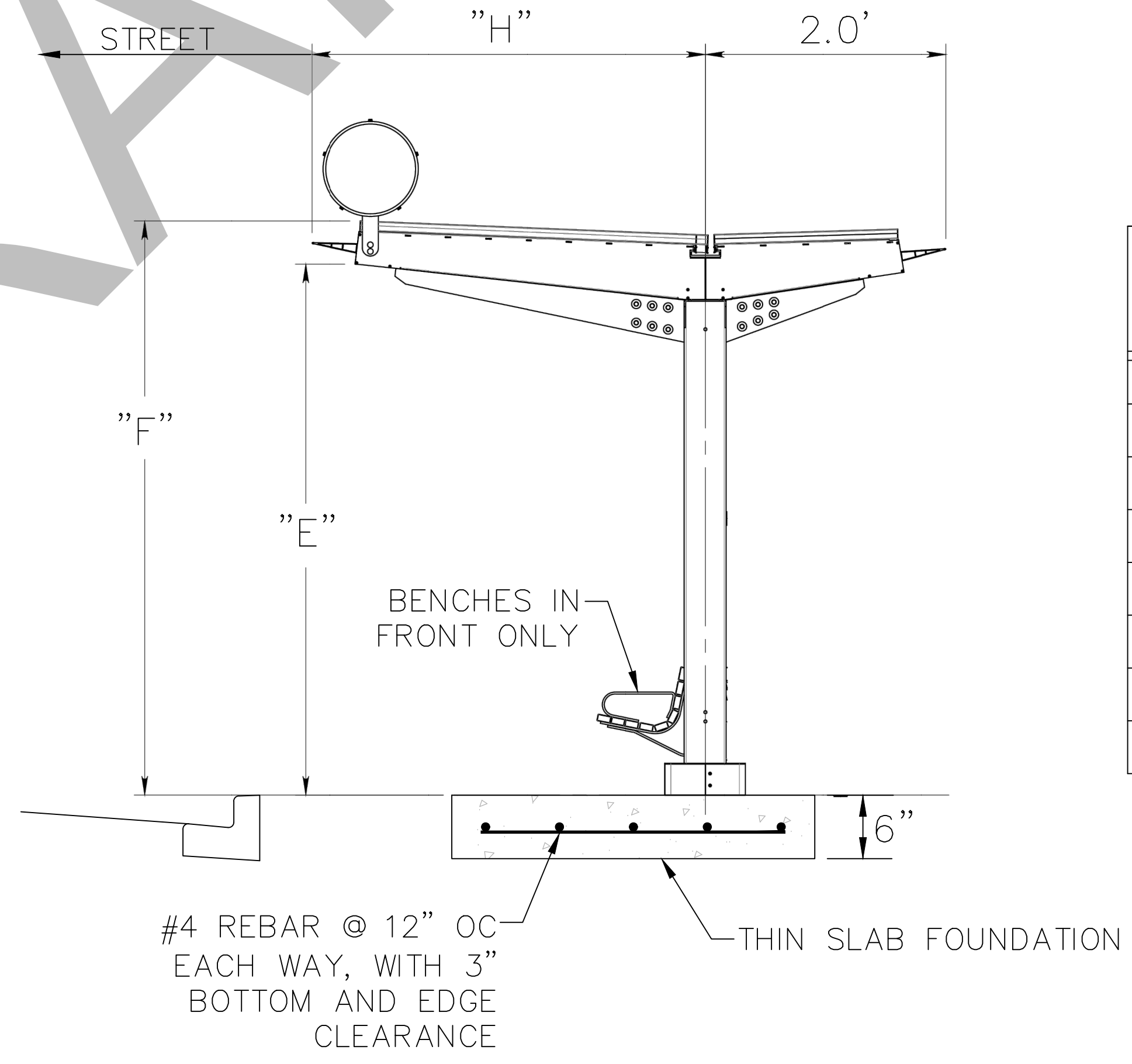
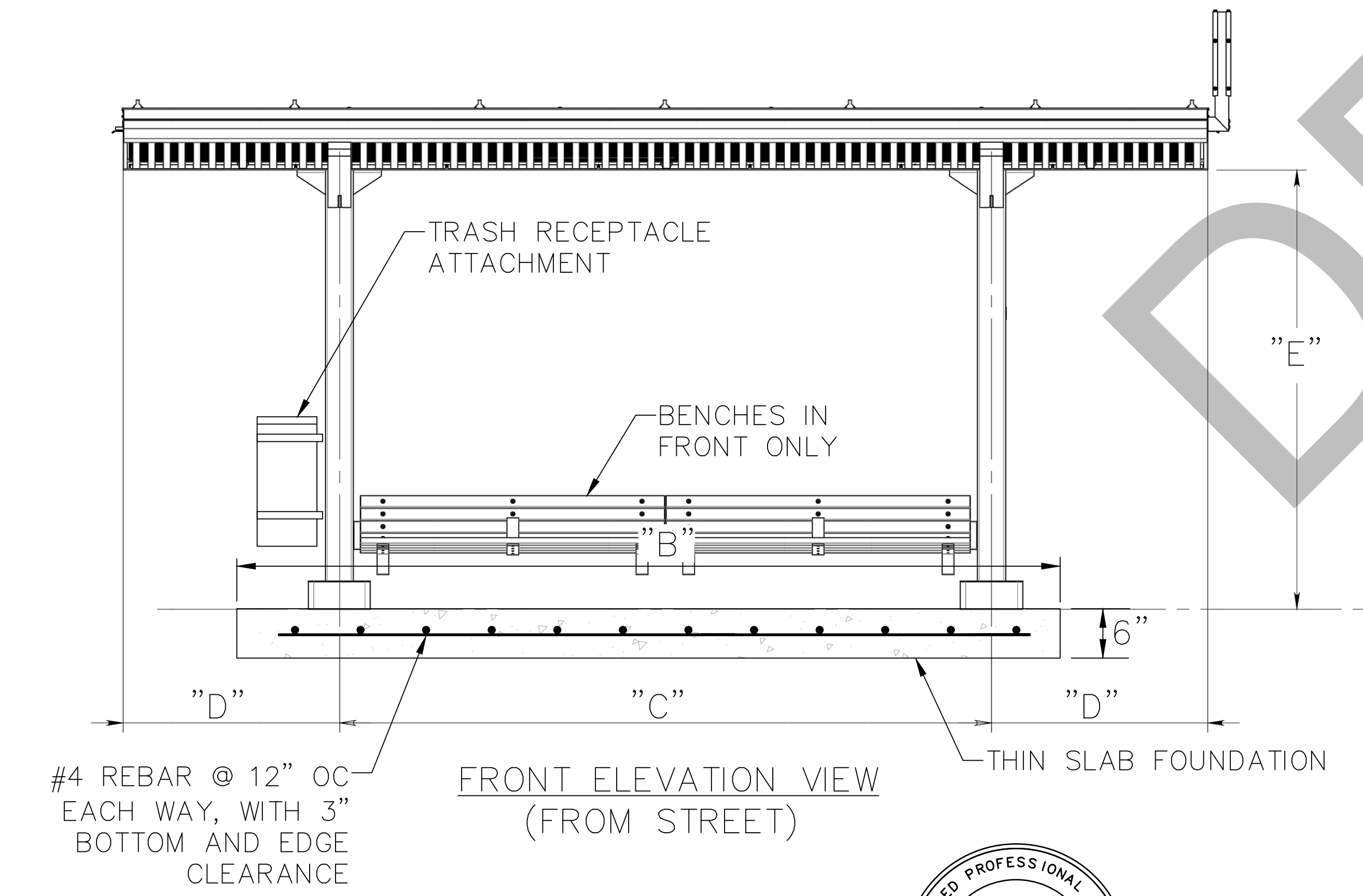

MBL  
MARK TARRALL R.C.E. NO. 71953 EXP. 12-31-23

DOKKEN ENGINEERING  
1450 FRAZEE ROAD, SUITE 100  
(858) 514-8377

DATE

PRIVATE CONTRACT

**BUS SHELTER DETAILS FOR IRIS RAPID CORRIDOR AND STATION DESIGN**  
IMPERIAL BEACH BLVD/CORONADO AVE (SMALL BUS SHELTER)

CITY OF SAN DIEGO, CALIFORNIA  
DEVELOPMENT SERVICES DEPARTMENT  
SHEET 18 OF 42 SHEETS

PROJECT NO. XXXXXX

FOR CITY ENGINEER	DATE	V.T.M.
DESCRIPTION	BY	APPROVED
		DATE
		FILMED
AS-BUILTS		
CONTRACTOR	DATE STARTED	
INSPECTOR	DATE COMPLETED	

1786-6299  
NAD83 COORDINATES

146-1739  
LAMBERT COORDINATES

XXXX-18-D

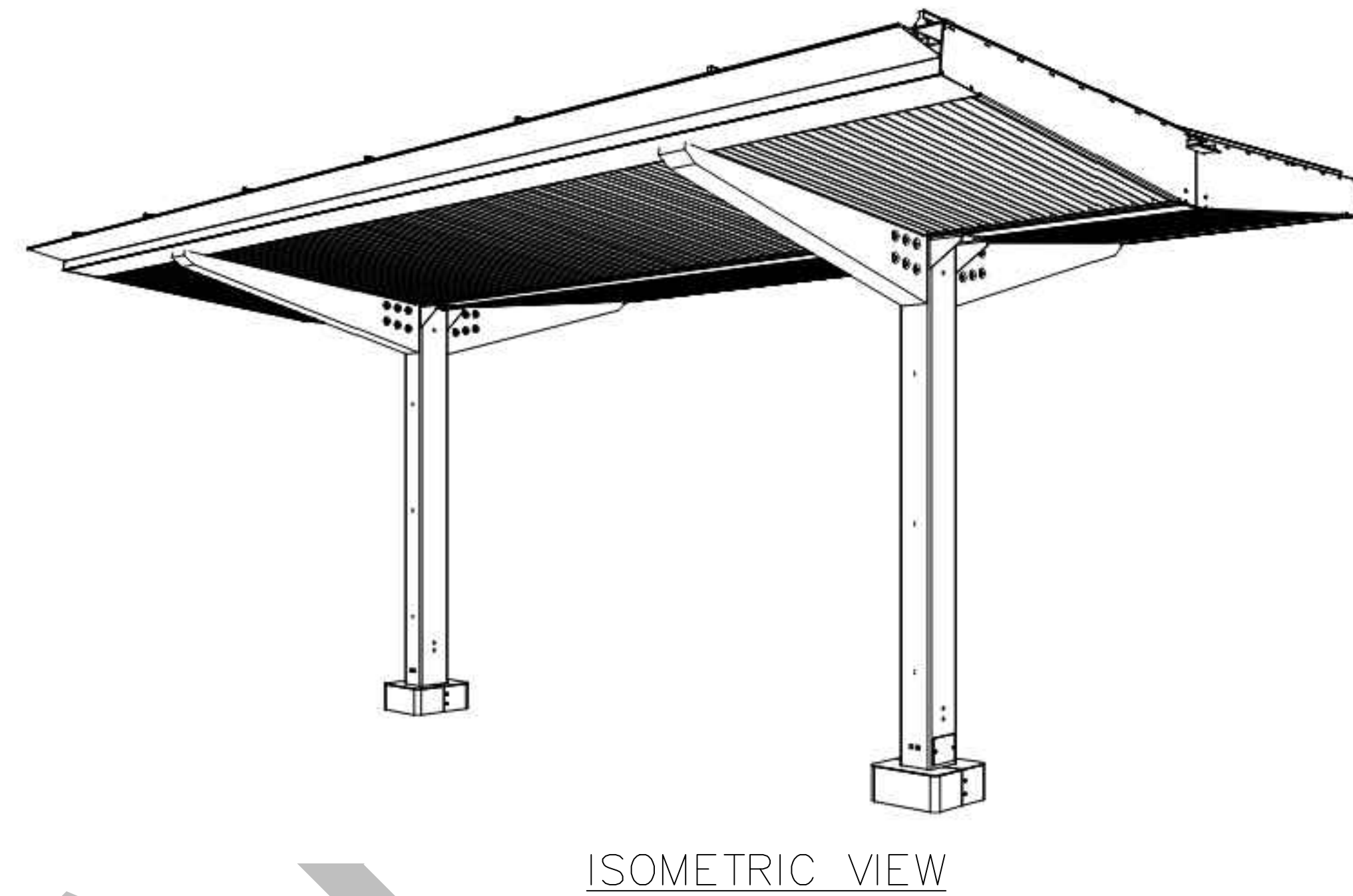
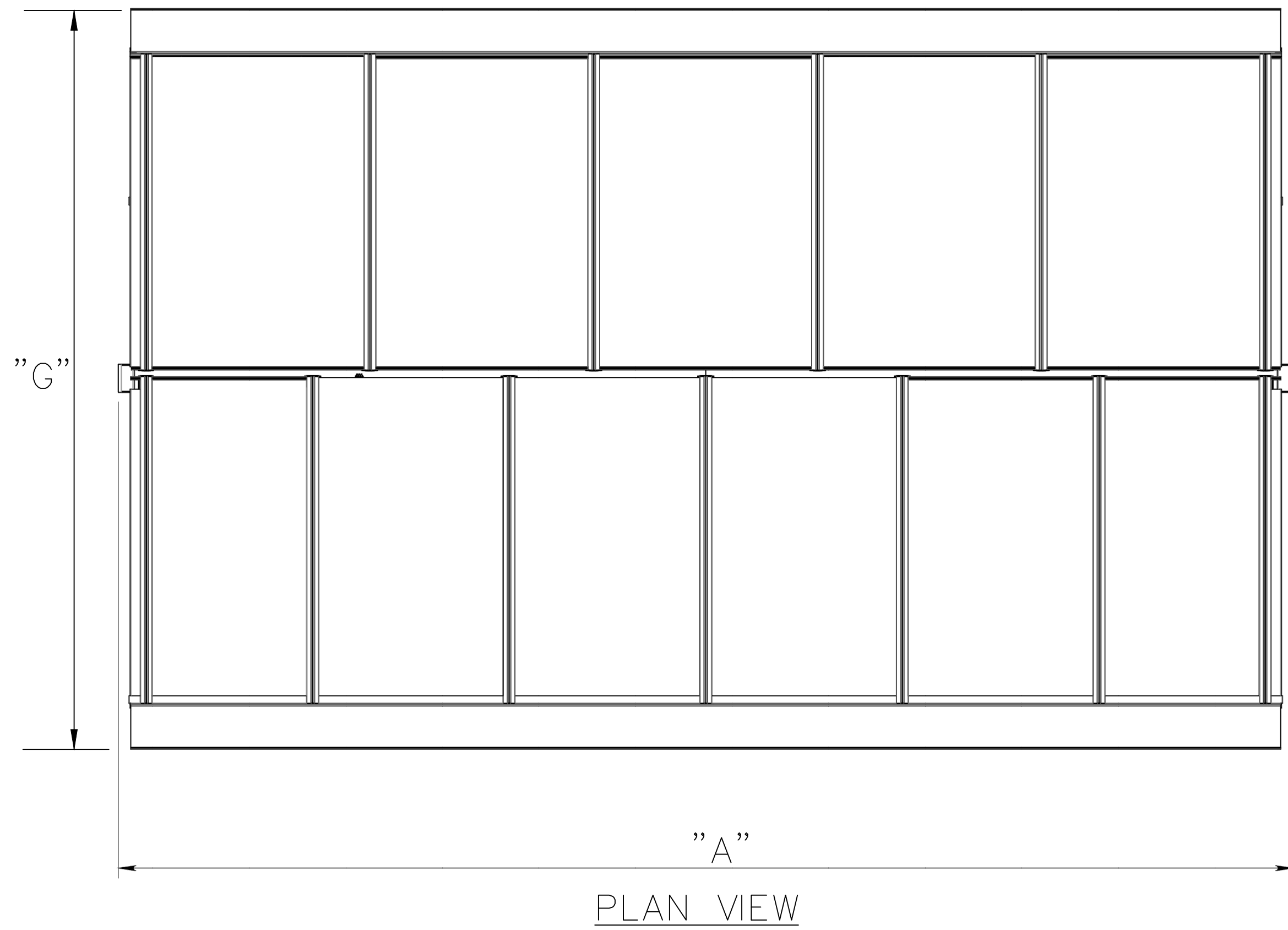

DIMENSION TABLE

	SEACOAST AT DAHLIA	SEACOAST AT IB PIER
A	22.00'	22.00'
B	19.60'	19.60'
C	17.00'	17.00'
D	2.50'	2.50'
E	8.40'	8.40'
F	9.05'	9.05'
G	10.00'	10.00'
H	5.00'	5.00'

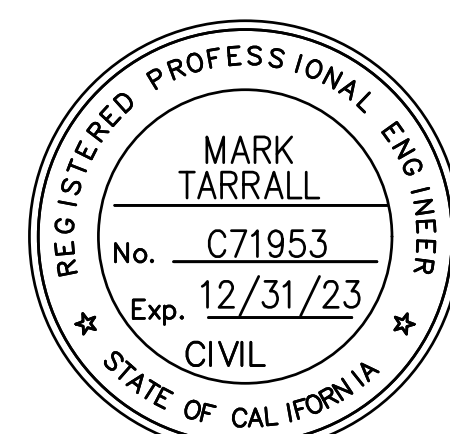
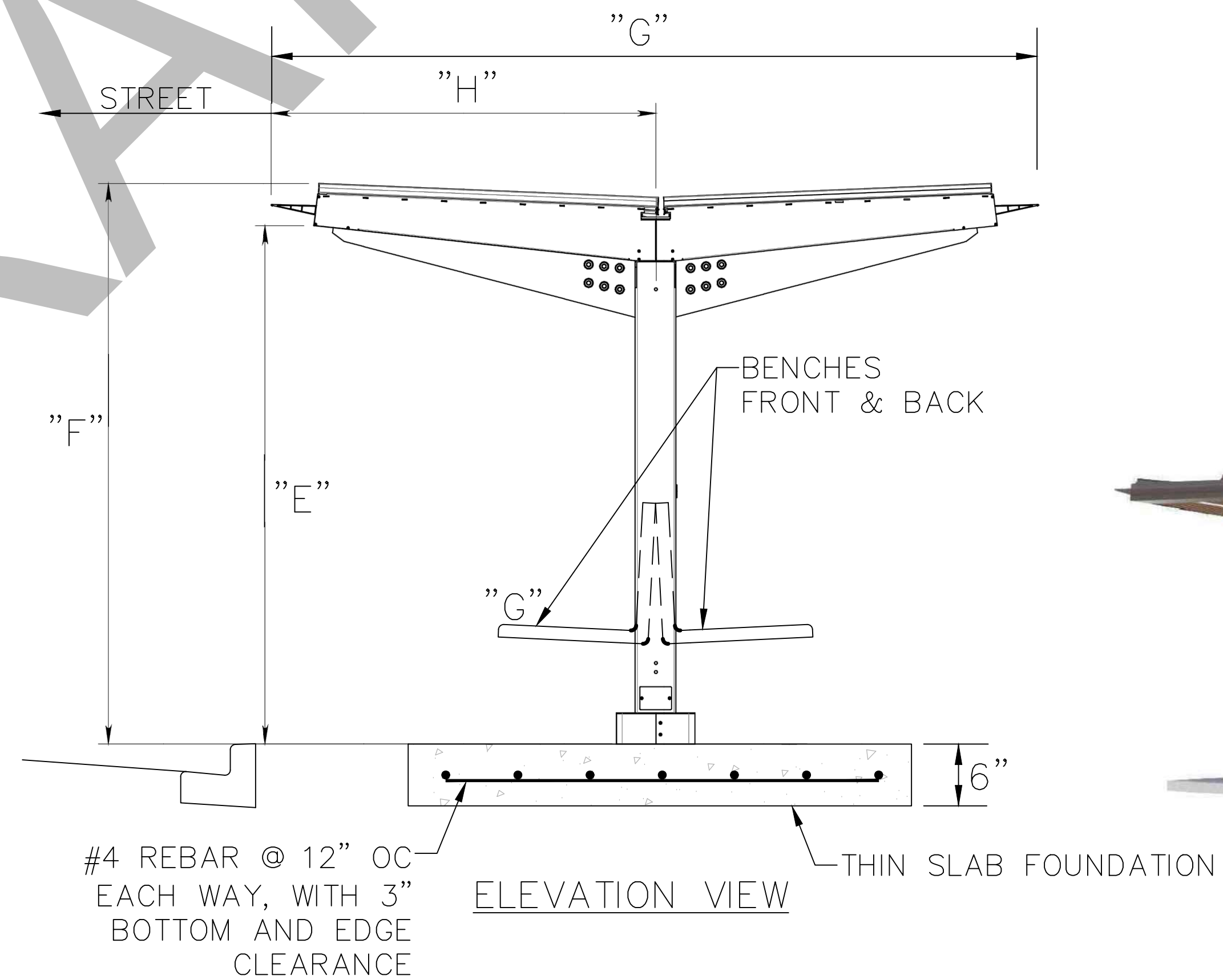
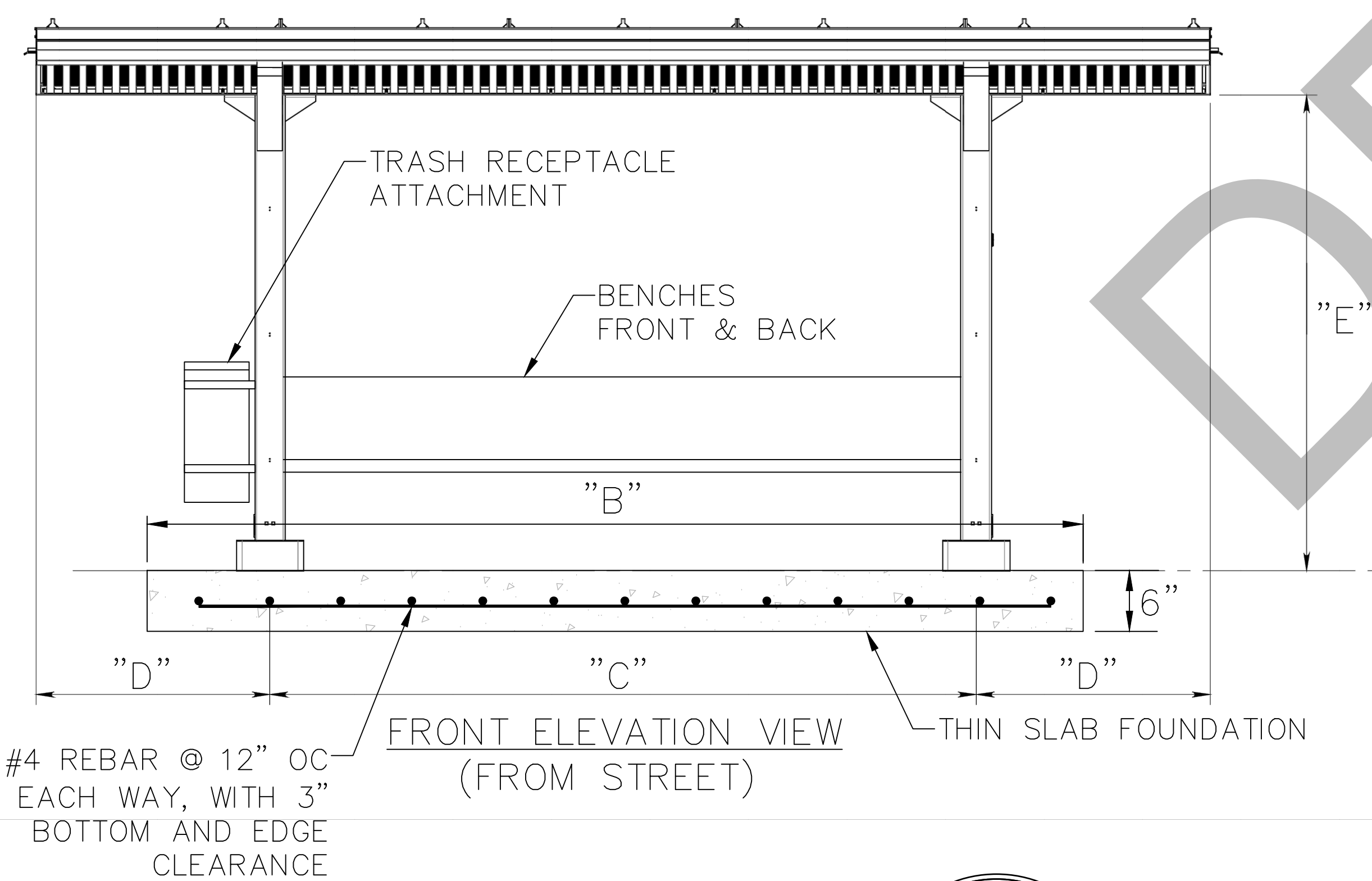

*MB Tarrall*  
 MARK TARRALL R.C.E. NO. 71953 EXP. 12-31-23

DOKKEN ENGINEERING  
 1450 FRAZEE ROAD, SUITE 100  
 (858) 514-8377

DATE

PRIVATE CONTRACT

**BUS SHELTER DETAILS FOR IRIS RAPID CORRIDOR AND STATION DESIGN**  
 IMPERIAL BEACH BLVD/CORONADO AVE (LARGE BUS SHELTER)

CITY OF SAN DIEGO, CALIFORNIA DEVELOPMENT SERVICES DEPARTMENT SHEET 19 OF 42 SHEETS		PROJECT NO. XXXXXX
FOR CITY ENGINEER	DATE	V.T.M.
DESCRIPTION	BY	APPROVED
		DATE
		FILMED
AS-BUILTS		
CONTRACTOR	DATE STARTED	
INSPECTOR	DATE COMPLETED	

1786-6299  
 NAD83 COORDINATES  
 146-1739  
 LAMBERT COORDINATES

XXXXX-19-D

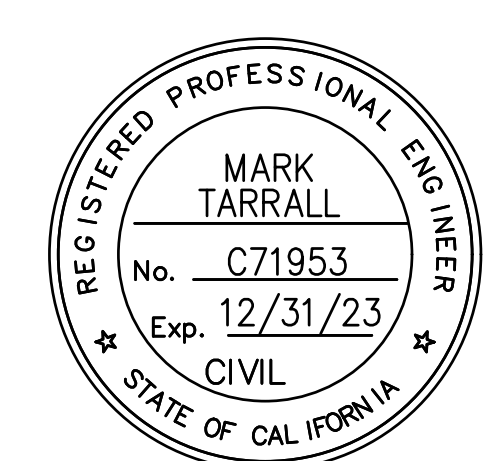
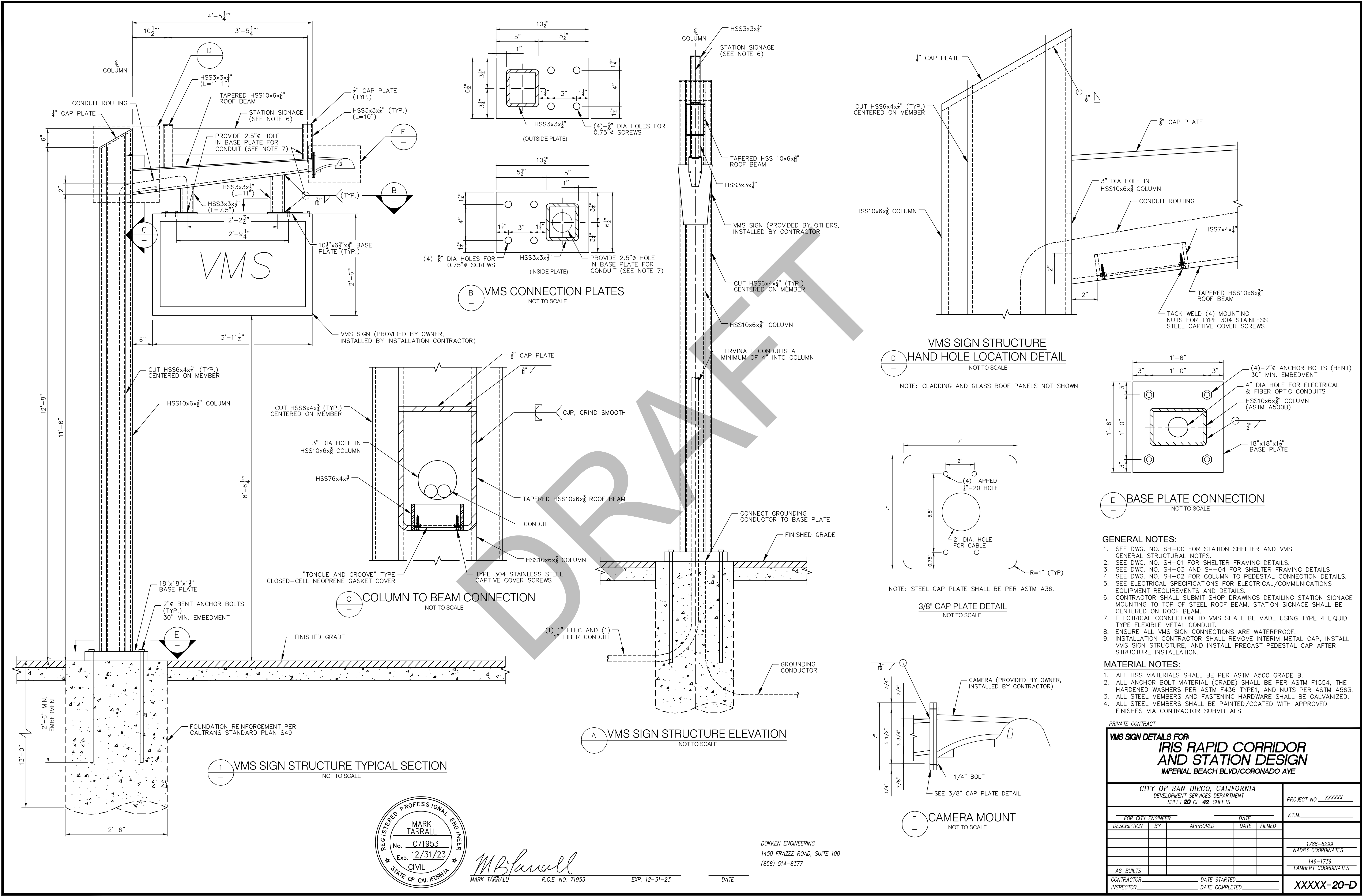

*MB Tarrall*  
MARK TARRALL R.C.E. NO. 71953 EXP. 12-31-23

DOKKEN ENGINEERING  
1450 FRAZEE ROAD, SUITE 100  
(858) 514-8377

DATE

TRAFFIC SIGNAL GENERAL NOTES:

- 1. PULL BOXES SHALL BE NO. 6 AND CONDUIT 3" UNLESS NOTED OTHERWISE.
2. LOCATIONS OF ALL UNDERGROUND UTILITIES ARE APPROXIMATE. IT IS THE RESPONSIBILITY OF THE CONTRACTOR TO DETERMINE AND VERIFY THE EXACT LOCATIONS AND CONDITIONS ON THE JOB SITE.
3. THE TRAFFIC SIGNAL CONTRACTOR SHALL OBTAIN A TRAFFIC CONTROL PLAN PERMIT FROM THE CITY OF SAN DIEGO DEVELOPMENT SERVICES DEPARTMENT PERMIT CENTER A MINIMUM OF FIVE (5) WORKING DAYS PRIOR TO START OF WORK.
4. ALL TRAFFIC SIGNAL POLE FOUNDATIONS SHALL HAVE A 3" CONDUIT INSTALLED TO THE ADJACENT NO. 6 PULL BOX. THE CONTROLLER FOUNDATION SHALL HAVE A SPARE 3" CONDUIT INSTALLED TO THE ADJACENT NO. 6 PULL BOX FOR FUTURE USE AS SHOWN ON CONDUIT SCHEDULE. (NEEDS TO BE ADDED AS A NOTE AT THE BOTTOM OF THE CONDUIT SCHEDULE)
A. ALL CONDUIT CROSSINGS SHALL INCLUDE A MINIMUM OF TWO (2) 3" CONDUITS.
5. THE TRAFFIC SIGNAL CONTRACTOR IS RESPONSIBLE FOR THE LAYOUT AND INSTALLATION OF LOOP DETECTORS, TRAFFIC STRIPING, PAVEMENT MARKINGS, PARKING REMOVAL AND TRAFFIC SIGNING (EXCEPT "G" SERIES STREET NAME SIGNS) AS SHOWN ON THESE PLANS.
A. THE TRAFFIC SIGNAL CONTRACTOR SHALL OBTAIN THE APPROVAL OF CITY RESIDENT TRAFFIC ENGINEER (ETS DIVISION) OF THE LOOP LOCATIONS PRIOR TO CUTTING, AS WELL AS, PRIOR TO ANY INSTALLATION AND/OR REMOVAL OF STRIPING, PAVEMENT MARKING, PARKING REMOVAL AND SIGN LOCATIONS.
B. THE TRAFFIC SIGNAL CONTRACTOR IS RESPONSIBLE FOR THE REMOVAL OF ALL UNNECESSARY AND CONFLICTING STRIPING AND PAVEMENT MARKINGS.
C. THE TRAFFIC SIGNAL CONTRACTOR IS RESPONSIBLE FOR REMOVAL OF ALL PAVEMENT MARK-OUTS.
6. THE TRAFFIC SIGNAL CONTRACTOR SHALL NOT ERECT ANY SIGNAL STANDARDS MORE THAN THREE (3) WEEKS PRIOR TO SCHEDULED TRAFFIC SIGNAL TURN-ON.
7. CONTRACTOR SHALL PROVIDE ALL CABLING AND CONDUCTORS NECESSARY TO PERFORM ALL FUNCTIONS SHOWN ON THESE PLANS.
8. ALL POLES, CONDUIT, PULL BOXES, STRIPING AND LOOP DETECTOR LOCATIONS SHOWN ON THESE PLANS ARE APPROXIMATE. ACTUAL LOCATIONS SHALL BE DETERMINED BY FIELD CONDITIONS AT THE TIME ON CONSTRUCTION AND AS DIRECTED BY THE CITY OF SAN DIEGO.
9. ROUTING AND LOCATIONS OF UNDERGROUND ELECTRICAL SYSTEM IS DIAGRAMMATIC AND SUBJECT TO APPROVAL OF THE CITY ELECTRICAL ENGINEER. UNDERGROUND ELECTRICAL LINES AND SUBSURFACE STRUCTURES MAY BE RELOCATED IF NECESSARY TO CLEAR OTHER EXISTING UNDERGROUND FACILITIES.
10. ALL TREES AND SHRUBS SHALL BE TRIMMED OR REMOVED AS DETERMINED BY THE CITY RESIDENT ENGINEER AS REQUIRED TO MAINTAIN SIGNAL HEAD VISIBILITY AND SIGHT DISTANCE.
11. ALL VEHICLE HEADS SHALL BE 12" L.E.D WITH AN INCANDESCENT LOOK AND BACKPLATES.
12. ALL VEHICLE DETECTOR LOOPS SHALL BE TYPE "E" AS SHOWN ON THIS PLAN.
A. DETECTOR LOOPS SHALL BE 6" DIAMETER WITH 10' SPACING AND POSITIONED IN CENTER OF LANE UNLESS OTHERWISE SHOWN.
B. FRONT DETECTOR LOOPS SHALL BE TYPE "E" MODIFIED LOOPS PER SDE-104.
C. ALL LOOP LAYOUTS SHALL INCLUDE LAYOUT OF HOMERUN LINES, WHICH MUST BE APPROVED PRIOR TO INSTALLATION
D. BICYCLE DETECTOR LOOPS SHALL BE TYPE Q.
13. PEDESTRIAN SIGNAL INDICATIONS AND PUSH BUTTONS SHALL BE INTERNATIONAL SYMBOLS. PEDESTRIAN SIGNAL INDICATIONS SHALL BE 16" X 18" L.E.D COUNTDOWN TIMER WITH AN INCANDESCENT LOOK. PEDESTRIAN PUSH BUTTONS SHALL BE 2" PER ADA REQUIREMENTS.
14. ALL CROSSWALKS SHALL BE CONTINENTAL TYPE PER SDM-116.
15. PEDESTRIAN PUSH BUTTON HOUSING COLOR SHALL MATCH COLOR NO. 33538 OF FED-STD-595 WHEN PEDESTRIAN PUSH BUTTONS ARE PLACED ON A TRAFFIC SIGNAL POLE.

STRIPING AND SIGNING GENERAL NOTES:

- 1. INSTALLATION OF ALL STRIPING, SIGNS AND PAVEMENT MARKERS SHALL BE THE RESPONSIBILITY OF THE CONTRACTOR.
2. ALL STRIPING AND SIGNING SHALL CONFORM TO THE MOST RECENTLY ADOPTED EDITION OF THE FOLLOWING MANUALS:
DESCRIPTION EDITION DOCUMENT NO.
STANDARD SPECIFICATIONS FOR PUBLIC WORKS CONSTRUCTION (GREENBOOK), 2018 EDITION 2018 PWPI010119-01
CITY OF SAN DIEGO STANDARD DRAWINGS FOR PUBLIC WORKS CONSTRUCTION, 2018 EDITION 2018 PWPI010119-03
CALIFORNIA DEPARTMENT OF TRANSPORTATION MANUAL ON UNIFORM TRAFFIC CONTROL DEVICES (REVISION 3), 2014 EDITION 2018 PWPI030119-07
3. ALL SIGNING AND STRIPING IS SUBJECT TO THE APPROVAL OF THE CITY ENGINEER PRIOR TO INSTALLATION AND/OR REMOVAL.
4. THE CONTRACTOR SHALL REMOVE ALL CONFLICTING STRIPING, PAVEMENT MARKINGS AND LEGENDS BY SANDBLASTING AND/OR GRINDING WITH THE SEAL. ANY DEBRIS SHALL BE PROMPTLY REMOVED BY THE CONTRACTOR.
5. SIGN POSTS SHALL BE INSTALLED WITH SQUARE PERFORATED STEEL TUBING WITH A BREAKAWAY BASE PER CITY OF SAN DIEGO STANDARD DRAWING SDM-104.
6. ALL RAISED MEDIAN NOSES SHALL BE PAINTED YELLOW.
7. ALL SIGNS SHOWN ON THE STRIPING AND SIGNING PLANS SHALL BE NEW SIGNS PROVIDED AND INSTALLED BY THE CONTRACTOR, EXCEPT FOR EXISTING SIGNS SPECIFICALLY INDICATED TO BE RELOCATED OR TO REMAIN.
8. MARKED CROSSWALKS SHALL HAVE AN INSIDE DIMENSION OF 10 FEET UNLESS INDICATED OTHERWISE.
9. ALL LIMIT LINES/STOP LINES, CROSSWALK LINES, PAVEMENT LEGENDS, AND ARROWS (EXCEPT WITHIN BIKE LANES) SHALL BE THERMOPLASTIC.
10. THE CONTRACTOR SHALL NOTIFY THE CITY TRAFFIC ENGINEER AT (858) 495-4742 A MINIMUM OF FIVE (5) WORKING DAYS PRIOR TO AND UPON COMPLETION OF STRIPING AND SIGNING.

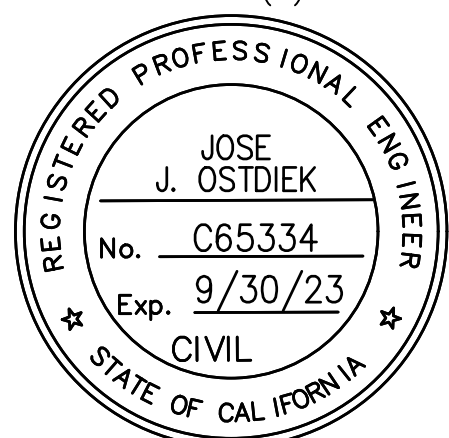

JOSE J. OSTDIEK R.C.E. NO. 65334 EXP. 09-30-23

DOKKEN ENGINEERING 1450 FRAZEE ROAD, SUITE 100 (858) 514-8377

DATE

LEGEND:

- AB ABANDON, IF APPLIED TO CONDUIT, REMOVE CONDUCTORS
BC REPLACE PULL BOX IN EXISTING CONDUIT RUN WITH A #6 PULL BOX
CB INSTALL CONDUIT INTO EXISTING PULL BOX.
CC CONNECT NEW AND EXISTING CONDUIT. REMOVE EXISTING CONDUCTORS AND INSTALL CONDUCTORS AS INDICATED
RC EQUIPMENT OR MATERIAL TO BE REMOVED AND BECOME THE PROPERTY OF THE CONTRACTOR
RS REMOVE AND SALVAGE EQUIPMENT
RL RELOCATE EQUIPMENT
SC SPLICE NEW TO EXISTING CONDUCTORS

BUS STOP AND TRANSIT CENTER GENERAL NOTES:

- 1. ALL PULL BOXES SHALL BE NO. 6 UNLESS OTHERWISE NOTED
2. CONDUIT TRENCHING SHALL BE PER SDRSD G-24A, TRENCH RESURFACING ASPHALT CONCRETE STREETS.
3. INSTALL CONDUIT BY HORIZONTAL DIRECTIONAL DRILLING WHERE INDICATED.

BUS STOP AND TRANSIT CENTER SYMBOLS:

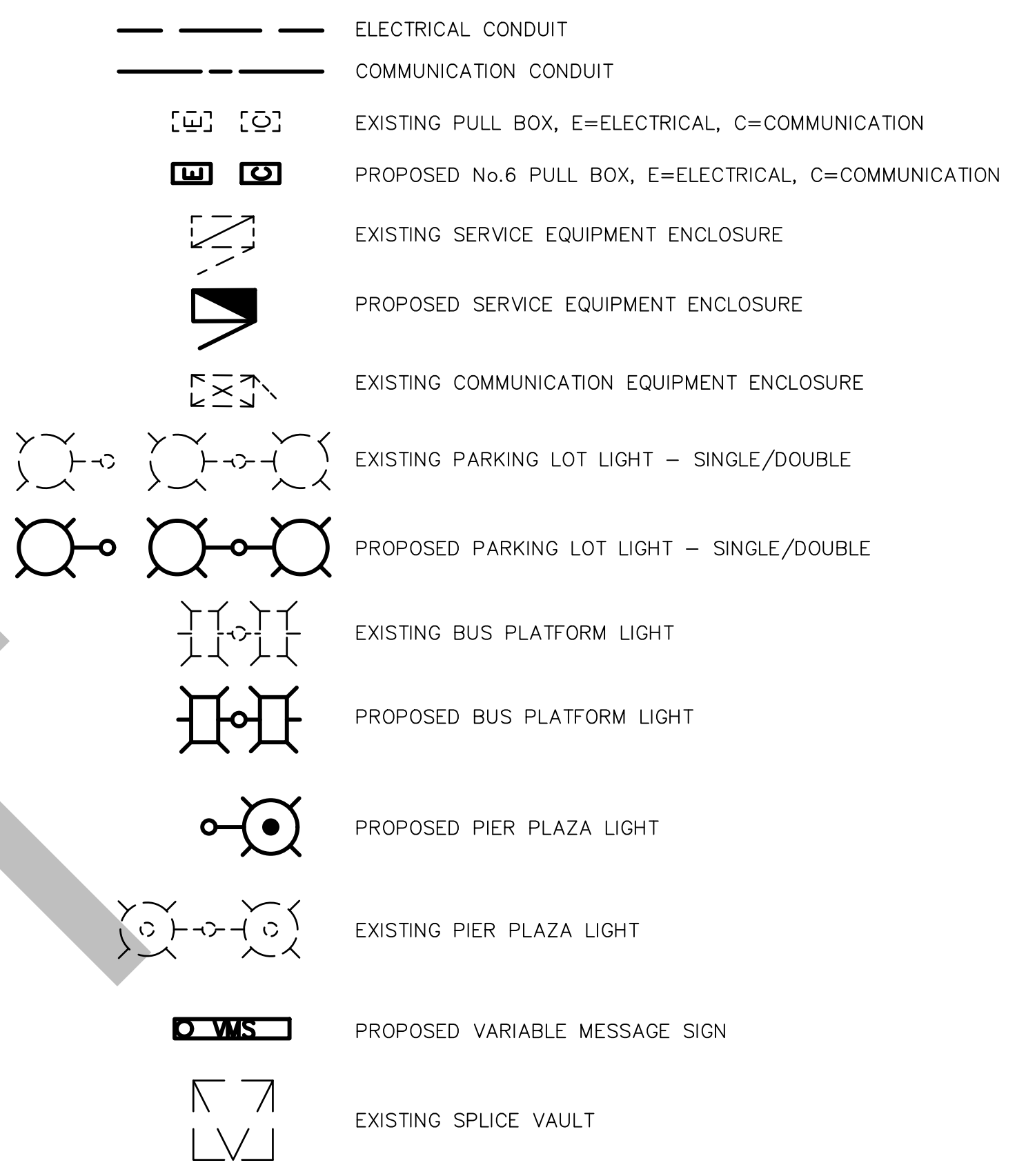

ABBREVIATIONS:

SMFO 24 STRAND SINGLE MODE FIBER OPTIC CABLE

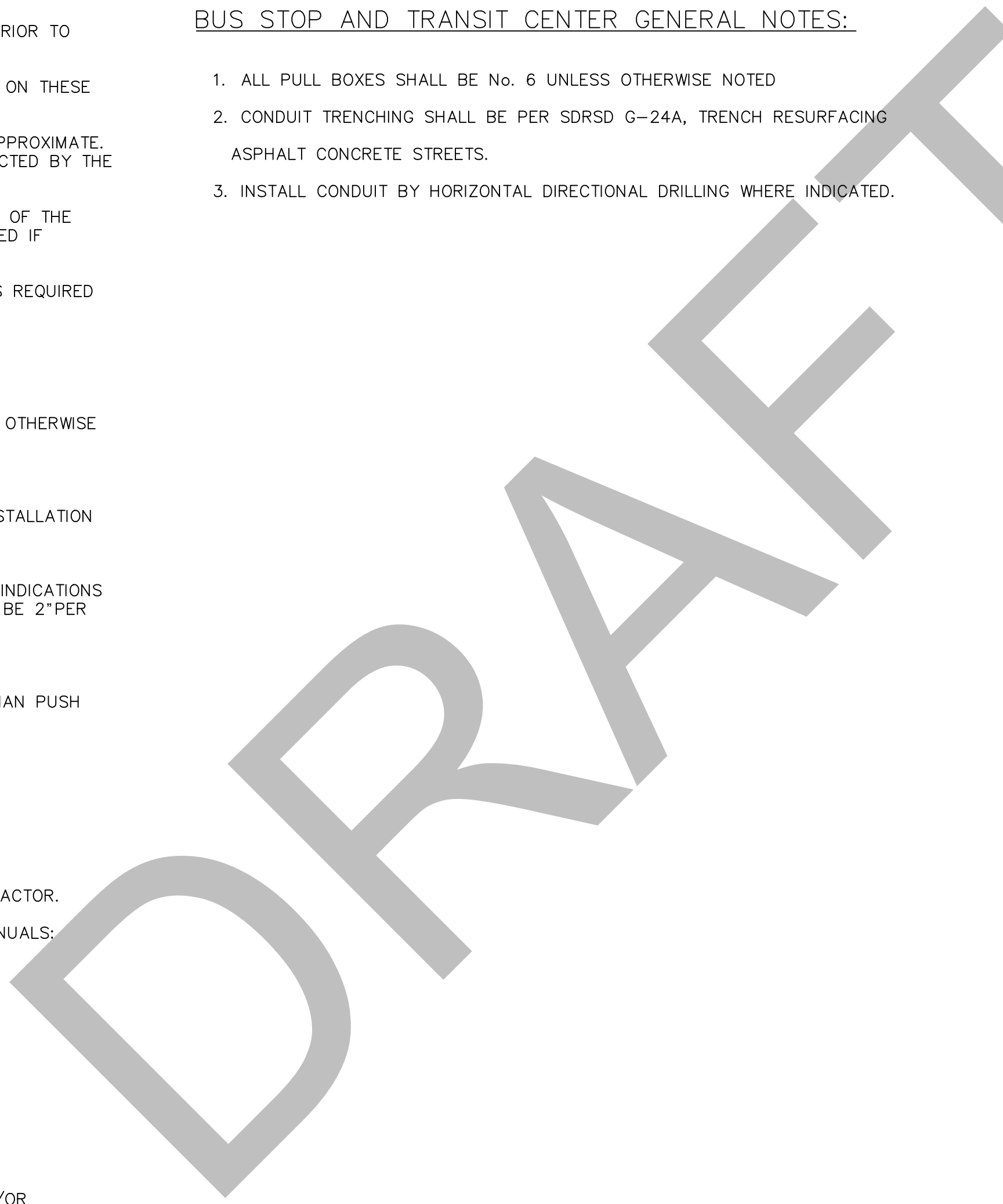

Form containing project information: PRIVATE CONTRACT, ELECTRICAL NOTES FOR IRIS RAPID CORRIDOR AND STATION DESIGN, IMPERIAL BEACH BLVD/CORONADO AVE, CITY OF SAN DIEGO, CALIFORNIA, DEVELOPMENT SERVICES DEPARTMENT, SHEET 21 OF 42 SHEETS, PROJECT NO. XXXXXX, V.T.M., AS-BUILTS, CONTRACTOR, INSPECTOR, DATE STARTED, DATE COMPLETED, XXXXX-21-D

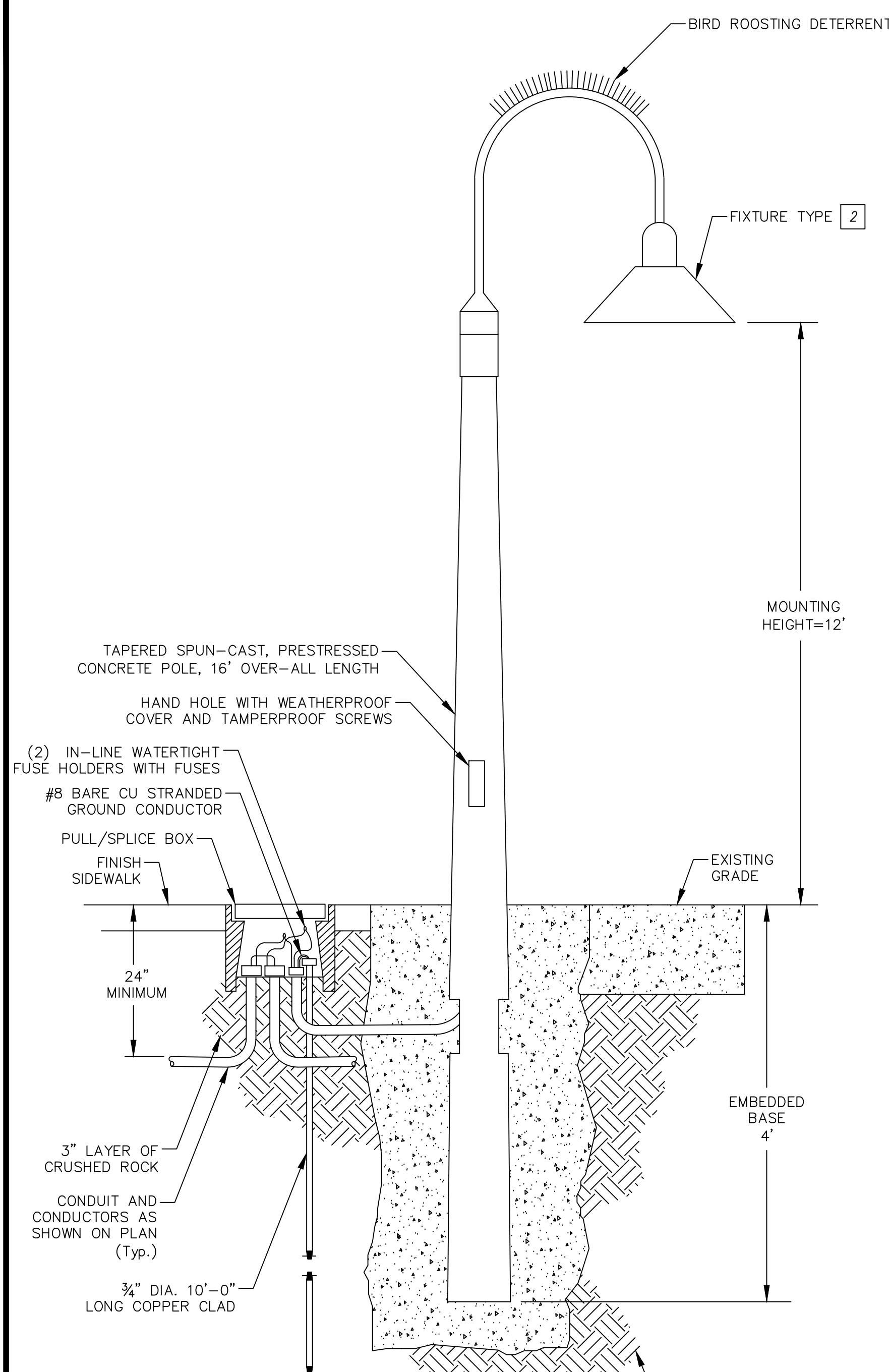

PIER PLAZA LIGHT DETAIL  
NOT TO SCALE



**CONSTRUCTION NOTES**

- 1 SPLICE NEW LIGHTING CONDUCTORS TO EXIST LIGHTING CONDUCTORS FOR Ckt 19.
- 2 SPUN-CAST, ROUND, TAPERED PRESTRESSED CONCRETE POLE, BLACK AND WHITE SPECKLED WITH GRAFFITI COATING. LED LUMINAIRE. VISIONAIRE LIGHTING: ODN-2-L-T3-42LC-4000K-BK-C1-H3

**CONDUIT NOTES**

- 1 3/4"C, 2#12 (Ltg)

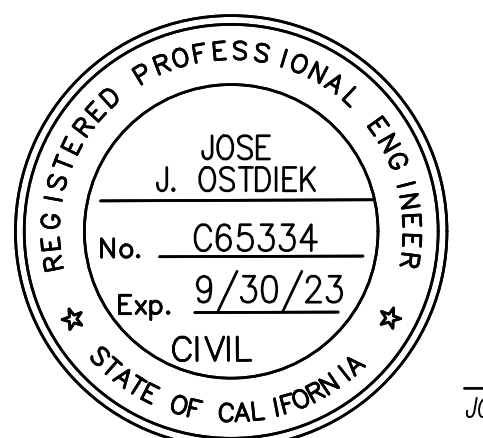
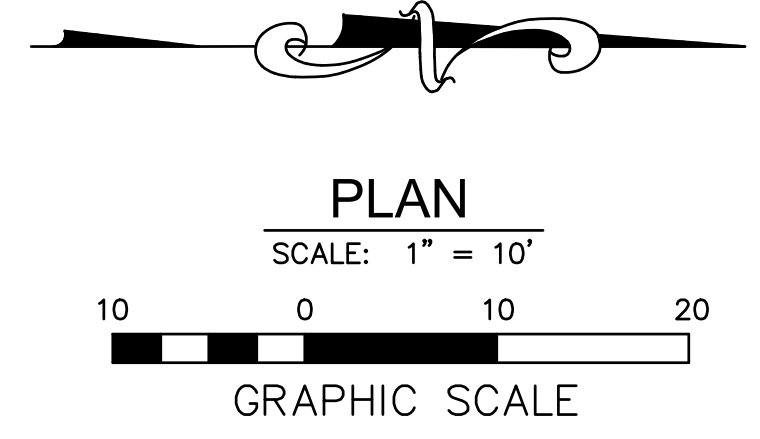

*Jose J. Ostdiek*  
JOSE J. OSTDIEK R.C.E. NO. 65334 EXP. 09-30-23

DOKKEN ENGINEERING  
1450 FRAZEE ROAD, SUITE 100  
(858) 514-8377

**NOTE:**  
THE CITY OF SAN DIEGO ENGINEER DOES NOT CONSTITUTE APPROVAL OF THIS SHEET AS IT ONLY REFLECTS IMPROVEMENTS LOCATED WITHIN CITY OF IMPERIAL BEACH JURISDICTION.

PRIVATE CONTRACT			
<b>ELECTRICAL PLANS FOR: IRIS RAPID CORRIDOR AND STATION DESIGN IMPERIAL BEACH BLVD/CORONADO AVE</b>			
CITY OF IMPERIAL BEACH, CALIFORNIA		PROJECT NO. XXXXXX	
SHEET 22 OF 42 SHEETS		V.T.M.	
DESCRIPTION	BY	APPROVED	DATE FILMED
AS-BUILTS			
CONTRACTOR		DATE STARTED	
INSPECTOR		DATE COMPLETED	
			<b>22-D</b>

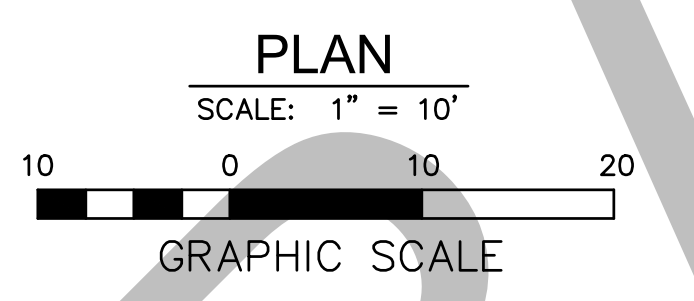
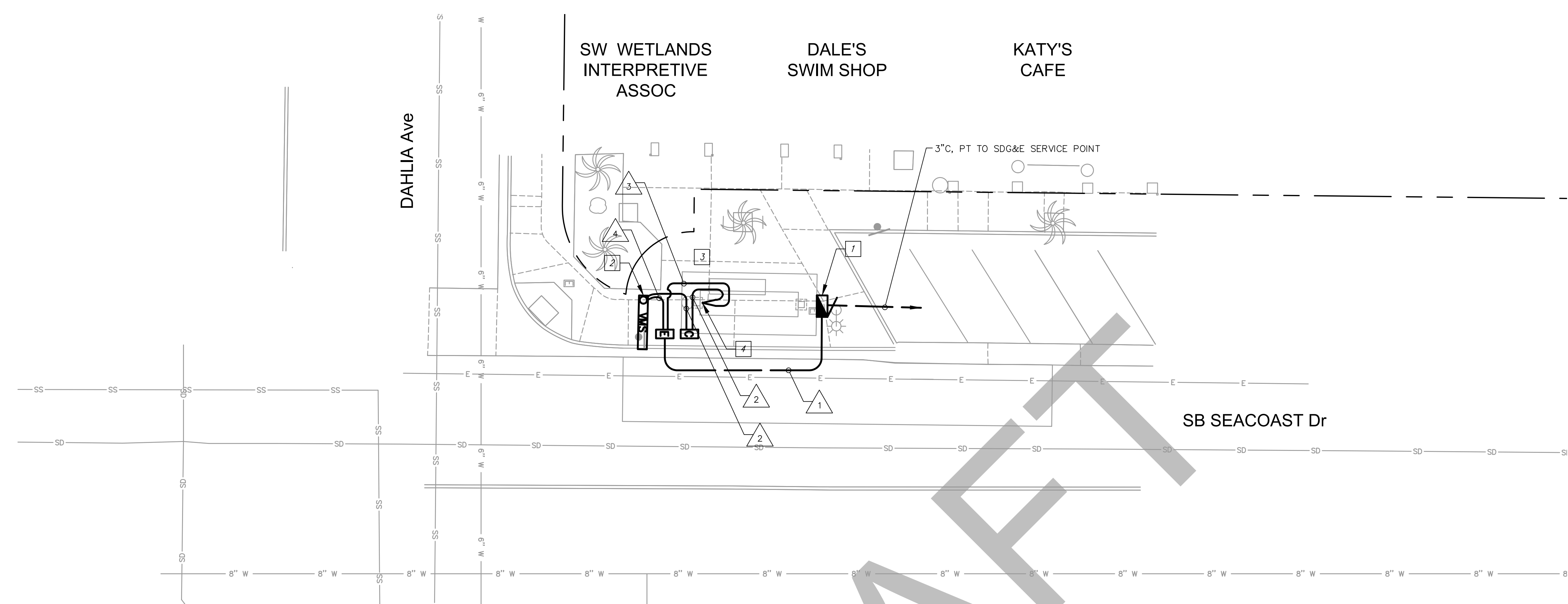

**CONSTRUCTION NOTES**

- 1 120/240V TYPE III-B SINGLE METER SERVICE EQUIPMENT ENCLOSURE WITH THE FOLLOWING BREAKERS:  
 100A, 240V, 2P, CB - MAIN  
 20A, 120V, 1P, CB - SHELTER LIGHTING  
 20A, 120V, 1P, CB - VMS  
 20A, 120V, 1P, CB - MODEM  
 20A, 120V, 1P, CB - SPARE  
 20A, 120V, 1P, CB - SPARE
- 2 VARIABLE MESSAGE SIGN.
- 3 INSTALL WIRELESS MODEM ON BUS SHELTER.
- 4 INSTALL CONDUIT STUB OUTS IN BUS SHELTER FOUNDATION.

**CONDUIT NOTES**

- 1 2\"/>

**GENERAL NOTE**

- 1. CONTRACTOR IS TO CONFIRM AN APPROVED LOCATION FOR THE ELECTRICAL SERVICE EQUIPMENT ENCLOSURE PRIOR TO PLACEMENT.

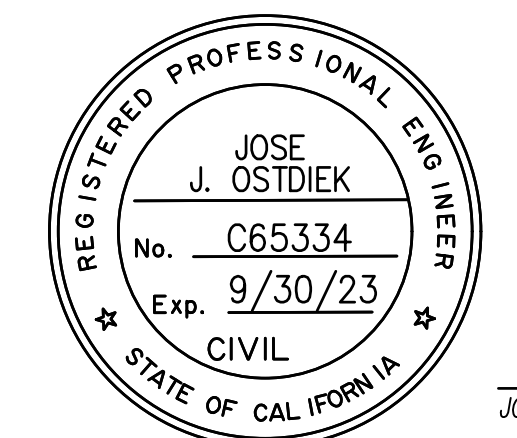

*Jose J. Ostdiek*  
 JOSE J. OSTDIEK R.C.E. NO. 65334 EXP. 09-30-23

DOKKEN ENGINEERING  
 1450 FRAZEE ROAD, SUITE 100  
 (858) 514-8377

**NOTE:**  
 THE CITY OF SAN DIEGO ENGINEER DOES NOT CONSTITUTE APPROVAL OF THIS SHEET AS IT ONLY REFLECTS IMPROVEMENTS LOCATED WITHIN CITY OF IMPERIAL BEACH JURISDICTION.

PRIVATE CONTRACT			
<b>ELECTRICAL PLANS FOR: IRIS RAPID CORRIDOR AND STATION DESIGN IMPERIAL BEACH BLVD/CORONADO AVE</b>			
CITY OF IMPERIAL BEACH, CALIFORNIA		PROJECT NO. XXXXXX	
SHEET 23 OF 42 SHEETS		V.T.M.	
DESCRIPTION	BY	APPROVED	DATE FILMED
AS-BUILTS			
CONTRACTOR		DATE STARTED	
INSPECTOR		DATE COMPLETED	
			<b>23-D</b>

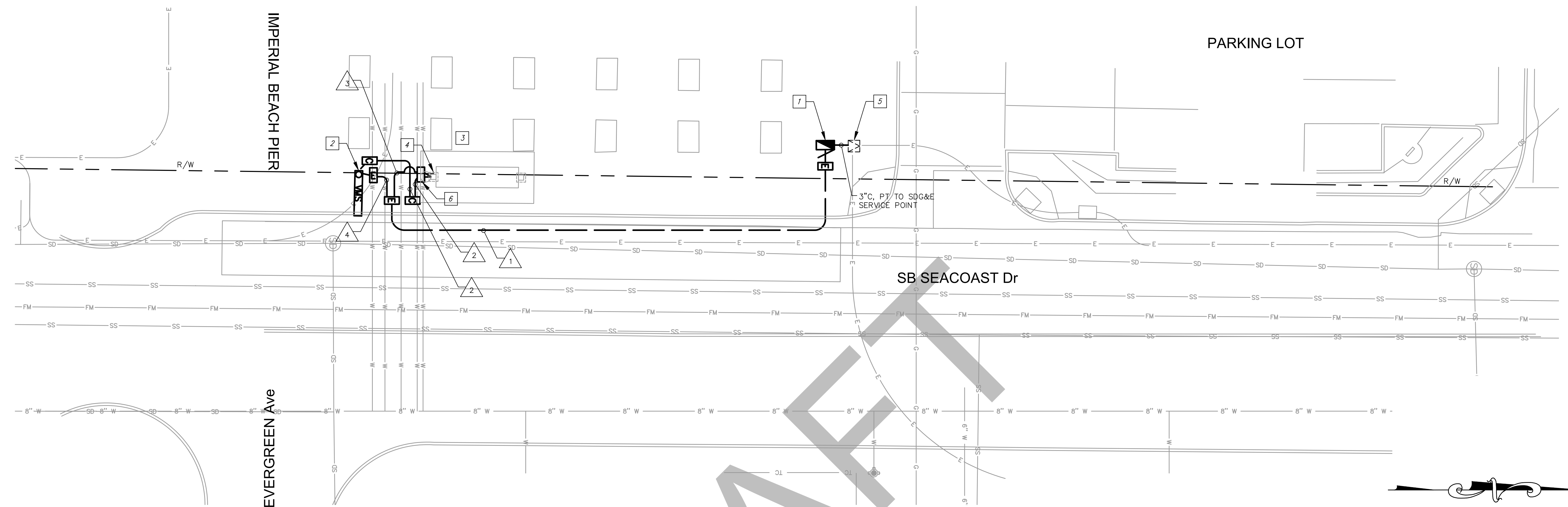

**CONSTRUCTION NOTES**

- 1 120/240V TYPE III-BF SINGLE METER SERVICE EQUIPMENT ENCLOSURE WITH THE FOLLOWING BREAKERS:  
 100A, 240V, 2P, CB - MAIN  
 20A, 120V, 1P, CB - SHELTER LIGHTING  
 20A, 120V, 1P, CB - VMS  
 20A, 120V, 1P, CB - MODEM  
 20A, 120V, 1P, CB - SPARE  
 20A, 120V, 1P, CB - SPARE
- 2 VARIABLE MESSAGE SIGN.
- 3 INSTALL WIRELESS MODEM ON BUS SHELTER.
- 4 INSTALL CONDUIT STUB OUTS IN BUS SHELTER FOUNDATION.
- 5 SDG&E TRANSFORMER. COORDINATE WITH SDG&E FOR CONNECTION.
- 6 INSTALL NO. 5 PULL BOX.

**CONDUIT NOTES**

- 1 2\"/>

**GENERAL NOTE**

- 1. CONTRACTOR IS TO CONFIRM AN APPROVED LOCATION FOR THE ELECTRICAL SERVICE EQUIPMENT ENCLOSURE PRIOR TO PLACEMENT.

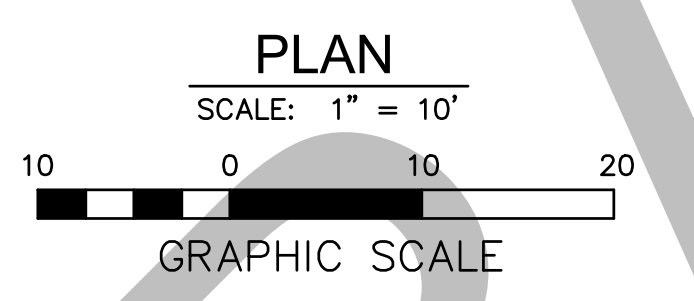

DRAFT



*Jose J. Ostdiek*  
 JOSE J. OSTDIEK R.C.E. NO. 65334 EXP. 09-30-23

DOKKEN ENGINEERING  
 1450 FRAZEE ROAD, SUITE 100  
 (858) 514-8377

**NOTE:**  
 THE CITY OF SAN DIEGO ENGINEER DOES NOT CONSTITUTE APPROVAL OF THIS SHEET AS IT ONLY REFLECTS IMPROVEMENTS LOCATED WITHIN CITY OF IMPERIAL BEACH JURISDICTION.

PRIVATE CONTRACT			
<b>ELECTRICAL PLANS FOR: IRIS RAPID CORRIDOR AND STATION DESIGN IMPERIAL BEACH BLVD/CORONADO AVE</b>			
CITY OF IMPERIAL BEACH, CALIFORNIA		PROJECT NO. XXXXXX	
SHEET 24 OF 42 SHEETS		V.T.M.	
DESCRIPTION	BY	APPROVED	DATE FILMED
AS-BUILTS			
CONTRACTOR		DATE STARTED	
INSPECTOR		DATE COMPLETED	
			<b>24-D</b>



**CONSTRUCTION NOTES**

- 1 120/240V TYPE III-B SINGLE METER SERVICE EQUIPMENT ENCLOSURE WITH THE FOLLOWING BREAKERS:  
 100A, 240V, 2P, CB - MAIN  
 20A, 120V, 1P, CB - SHELTER LIGHTING  
 20A, 120V, 1P, CB - VMS  
 20A, 120V, 1P, CB - VMS  
 20A, 120V, 1P, CB - SPARE  
 20A, 120V, 1P, CB - SPARE
- 2 VARIABLE MESSAGE SIGN.
- 3 SEE FIBER OPTIC CABLE SYSTEMS SHEETS.
- 4 INSTALL CONDUIT STUB OUTS IN BUS SHELTER FOUNDATION.
- 5 INSTALL CONDUIT BY HORIZONTAL DIRECTIONAL DRILLING.

**GENERAL NOTE**

- 1. CONTRACTOR IS TO CONFIRM AN APPROVED LOCATION FOR THE ELECTRICAL SERVICE EQUIPMENT ENCLOSURE PRIOR TO PLACEMENT.

**CONDUIT NOTES**

- 1 2" C, 4#10 (VMS), 2#10 (SHELTER Ltg), 2#14 (PEU), 1#8 (G)
- 2 2" C, VMS COMMUNICATION CABLE
- 3 2" C, 2#10 (SHELTER Ltg), 2#14 (PEU), 1#8 (G)
- 4 2" C, 2#10 (VMS), 1#8 (G)
- 5 2" C, PT

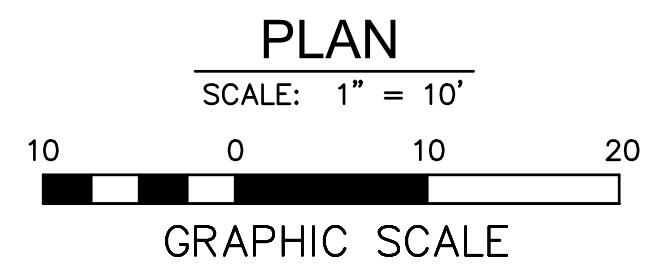
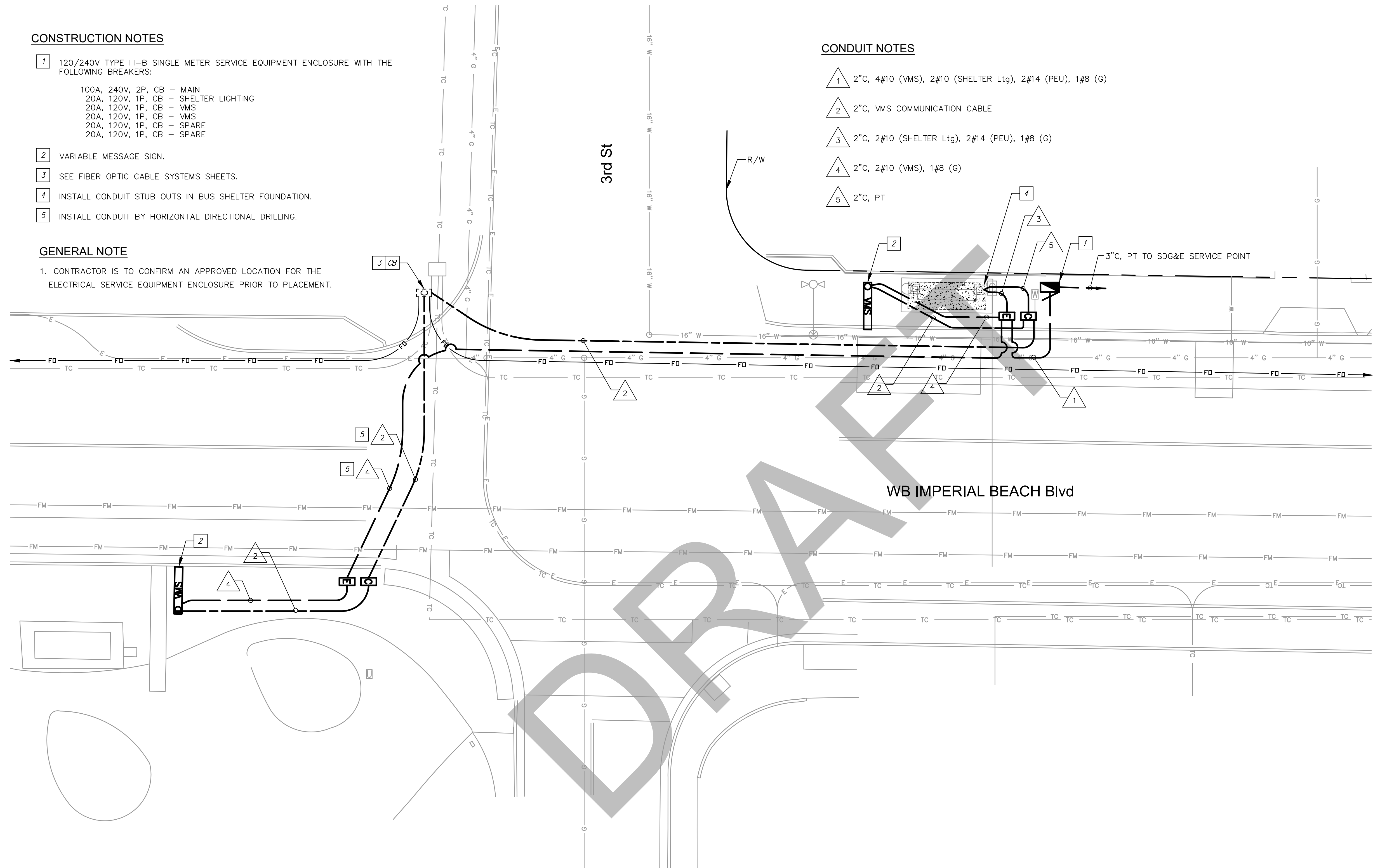

PRIVATE CONTRACT

**ELECTRICAL PLANS FOR:**  
**IRIS RAPID CORRIDOR**  
**AND STATION DESIGN**  
 IMPERIAL BEACH BLVD/CORONADO AVE

CITY OF IMPERIAL BEACH, CALIFORNIA		PROJECT NO. XXXXXX
SHEET 25 OF 42 SHEETS		V.T.M.
DESCRIPTION	BY	APPROVED
		DATE
		FILMED
		1786-6299
		NAD83 COORDINATES
		146-1739
		LAMBERT COORDINATES
AS-BUILTS		
CONTRACTOR		DATE STARTED
INSPECTOR		DATE COMPLETED

**25-D**

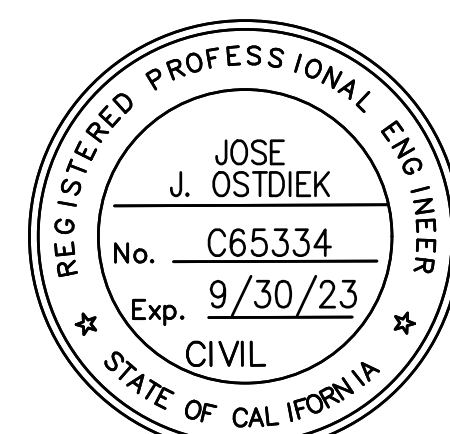

*Jose J. Ostdiek*  
 JOSE J. OSTDIEK R.C.E. NO. 65334 EXP. 09-30-23

DOKKEN ENGINEERING  
 1450 FRAZEE ROAD, SUITE 100  
 (858) 514-8377

**NOTE:**  
 THE CITY OF SAN DIEGO ENGINEER DOES NOT CONSTITUTE APPROVAL OF THIS SHEET AS IT ONLY REFLECTS IMPROVEMENTS LOCATED WITHIN CITY OF IMPERIAL BEACH JURISDICTION.

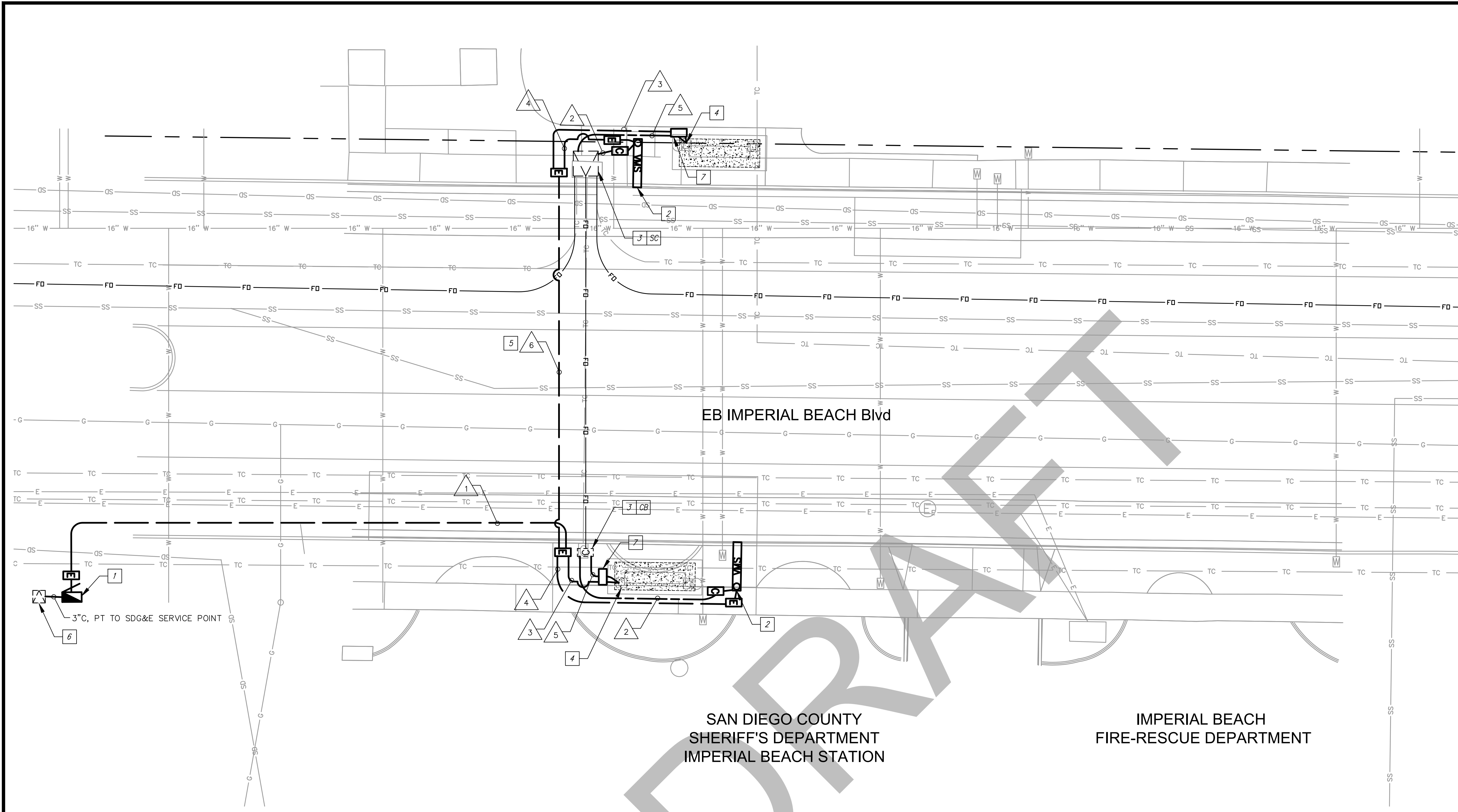

EB IMPERIAL BEACH Blvd

SAN DIEGO COUNTY  
SHERIFF'S DEPARTMENT  
IMPERIAL BEACH STATION

IMPERIAL BEACH  
FIRE-RESCUE DEPARTMENT

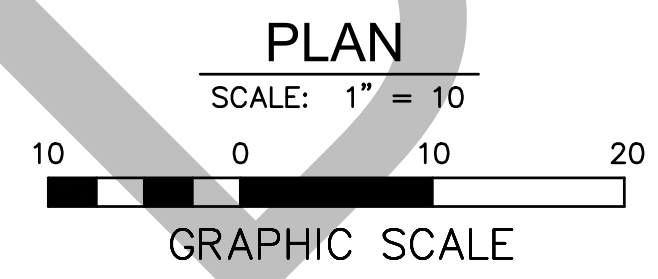

**CONSTRUCTION NOTES**

- 1 120/240V TYPE III-BF SINGLE METER SERVICE EQUIPMENT ENCLOSURE WITH THE FOLLOWING BREAKERS:  
 100A, 240V, 2P, CB - MAIN  
 20A, 120V, 1P, CB - SHELTER LIGHTING  
 20A, 120V, 1P, CB - SHELTER LIGHTING  
 20A, 120V, 1P, CB - VMS  
 20A, 120V, 1P, CB - VMS  
 20A, 120V, 1P, CB - SPARE  
 20A, 120V, 1P, CB - SPARE
- 2 VARIABLE MESSAGE SIGN.
- 3 SEE FIBER OPTIC CABLE SYSTEMS SHEETS.
- 4 INSTALL CONDUIT STUB OUTS IN BUS SHELTER FOUNDATION.
- 5 INSTALL CONDUIT BY HORIZONTAL DIRECTIONAL DRILLING.
- 6 SDG&E TRANSFORMER. COORDINATE WITH SDG&E FOR CONNECTION.
- 7 INSTALL No. 5 PULL BOX.

**CONDUIT NOTES**

- 1 2"C, 4#10 (VMS), 4#10 (SHELTER Ltg), 2#14 (PEU), 1#8 (G)
- 2 2"C, VMS COMMUNICATION CABLE
- 3 2"C, 2#10 (SHELTER Ltg), 2#14 (PEU), 1#8 (G)
- 4 2"C, 2#10 (VMS), 1#8 (G)
- 5 2"C, PT
- 6 2"C, 2#10 (VMS), 2#10 (SHELTER Ltg), 2#14 (PEU), 1#8 (G)

**GENERAL NOTE**

1. CONTRACTOR IS TO CONFIRM AN APPROVED LOCATION FOR THE ELECTRICAL SERVICE METERS AND PEDESTALS PRIOR TO PLACEMENT.

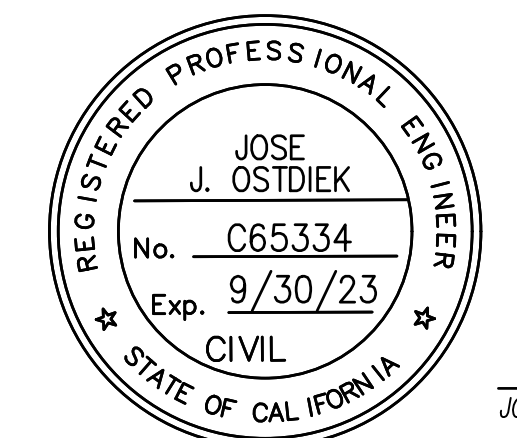

*Jose J. Ostdiek*  
 JOSE J. OSTDIEK R.C.E. NO. 65334 EXP. 09-30-23

DOKKEN ENGINEERING  
 1450 FRAZEE ROAD, SUITE 100  
 (858) 514-8377

**NOTE:**  
 THE CITY OF SAN DIEGO ENGINEER DOES NOT CONSTITUTE APPROVAL OF THIS SHEET AS IT ONLY REFLECTS IMPROVEMENTS LOCATED WITHIN CITY OF IMPERIAL BEACH JURISDICTION.

PRIVATE CONTRACT

**ELECTRICAL PLANS FOR:  
 IRIS RAPID CORRIDOR  
 AND STATION DESIGN  
 IMPERIAL BEACH BLVD/CORONADO AVE**

CITY OF IMPERIAL BEACH, CALIFORNIA		PROJECT NO. XXXXXX
SHEET 26 OF 42 SHEETS		V.T.M.
DESCRIPTION	BY	APPROVED
		DATE
		FILMED
AS-BUILTS		
CONTRACTOR		DATE STARTED
INSPECTOR		DATE COMPLETED

1786-6299  
 NAD83 COORDINATES  
 146-1739  
 LAMBERT COORDINATES

**26-D**

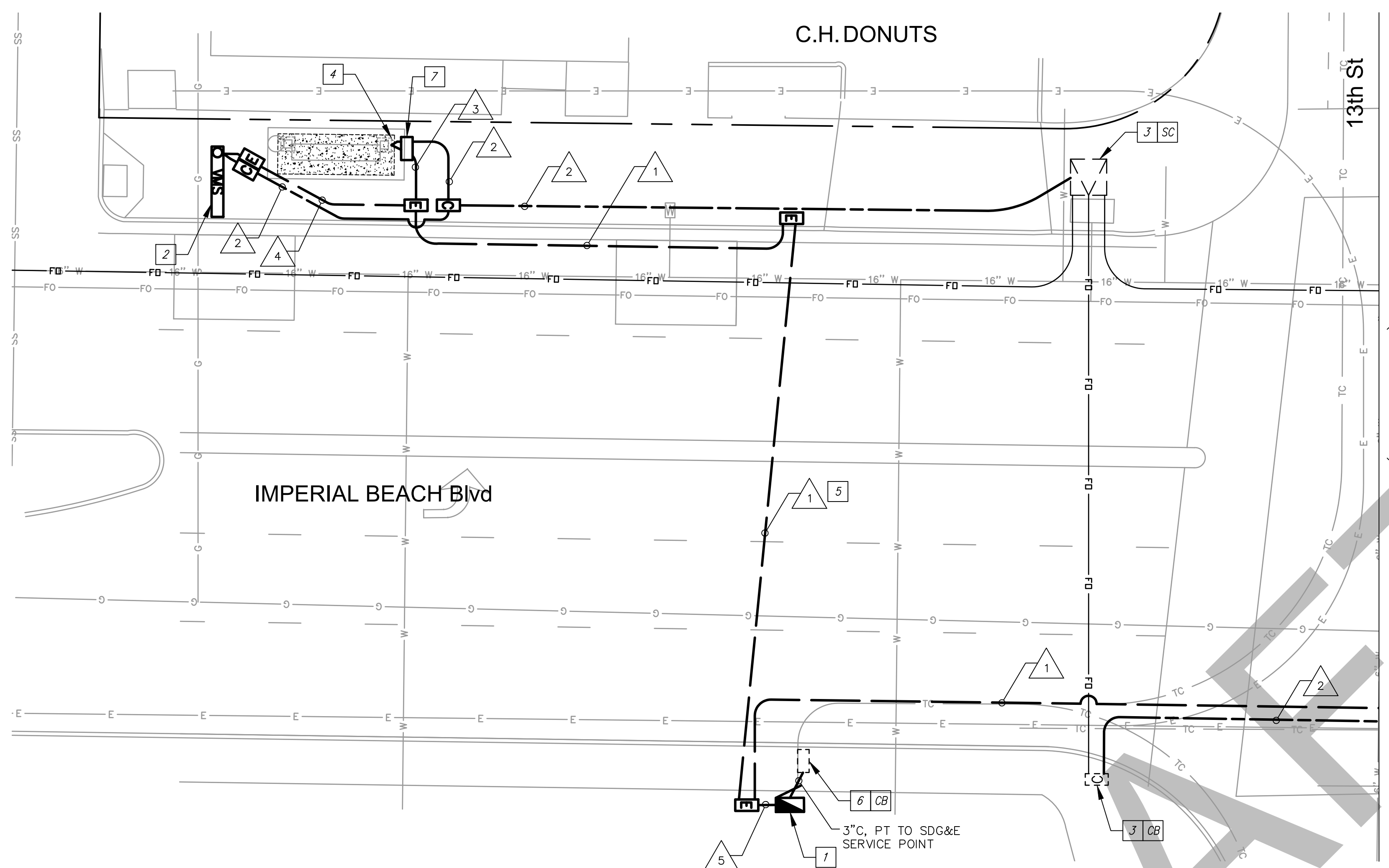

- CONSTRUCTION NOTES**
- 1 120/240V TYPE III-BF SINGLE METER SERVICE EQUIPMENT ENCLOSURE WITH THE FOLLOWING BREAKERS:  
 100A, 240V, 2P, CB - MAIN  
 20A, 120V, 1P, CB - SHELTER LIGHTING  
 20A, 120V, 1P, CB - SHELTER LIGHTING  
 20A, 120V, 1P, CB - VMS  
 20A, 120V, 1P, CB - VMS  
 20A, 120V, 1P, CB - SPARE  
 20A, 120V, 1P, CB - SPARE
  - 2 VARIABLE MESSAGE SIGN.
  - 3 SEE FIBER OPTIC CABLE SYSTEMS SHEETS.
  - 4 INSTALL CONDUIT STUB OUTS IN BUS SHELTER FOUNDATION.
  - 5 INSTALL CONDUIT BY HORIZONTAL DIRECTIONAL DRILLING.
  - 6 EXISTING SDG&E HANDHOLE. COORDINATE WITH SDG&E FOR CONNECTION.
  - 7 INSTALL No. 5 PULL BOX.

- CONDUIT NOTES**
- 1 2" C, 2#8 (VMS), 2#8 (SHELTER Ltg), 2#14 (PEU), 1#8 (G)
  - 2 2" C, VMS COMMUNICATION CABLE
  - 3 2" C, 2#8 (SHELTER Ltg), 2#14 (PEU), 1#8 (G)
  - 4 2" C, 2#8 (VMS), 1#8 (G)
  - 5 2" C, 4#8 (VMS), 4#8 (SHELTER Ltg), 2#14 (PEU), 1#8 (G)

**GENERAL NOTE**

1. CONTRACTOR IS TO CONFIRM AN APPROVED LOCATION FOR THE ELECTRICAL SERVICE METERS AND PEDESTALS PRIOR TO PLACEMENT.

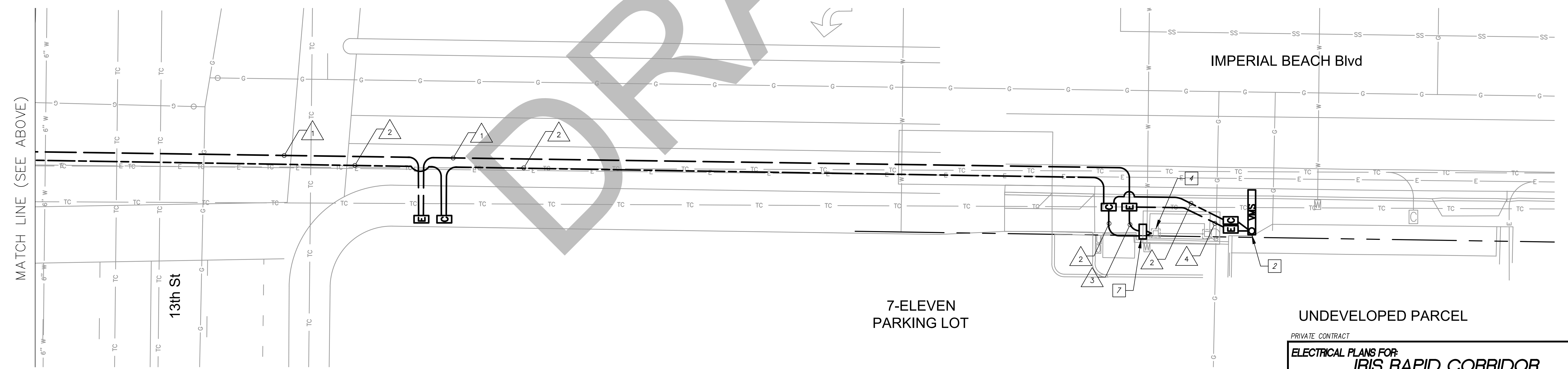
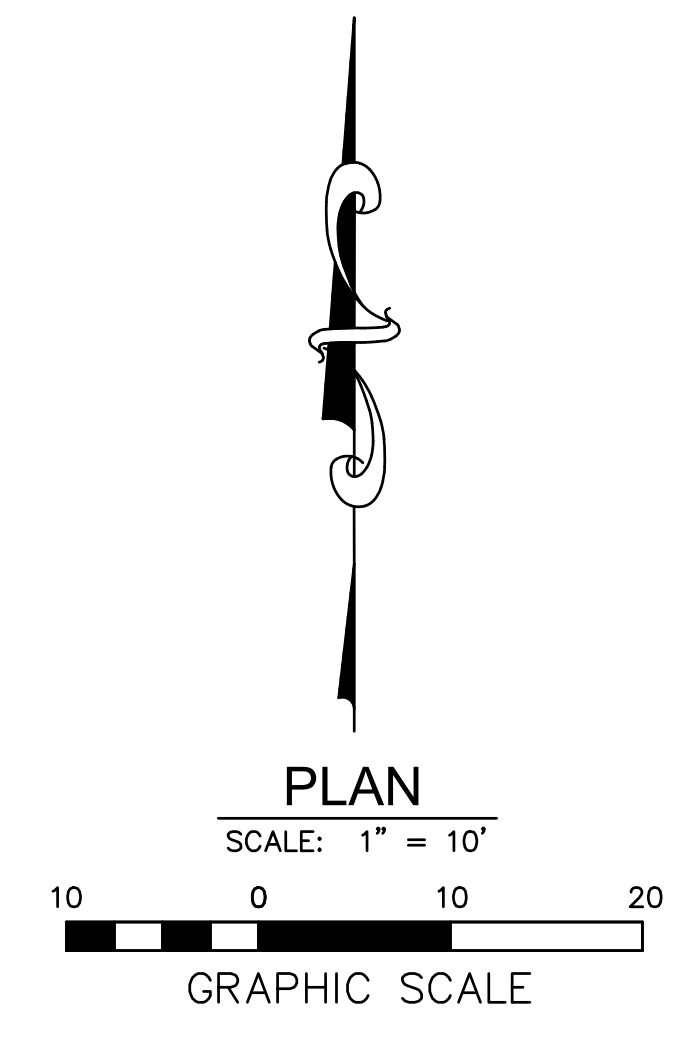

*Jose J. Ostdiek*  
 JOSE J. OSTDIEK R.C.E. NO. 65334 EXP. 09-30-23

DOKKEN ENGINEERING  
 1450 FRAZEE ROAD, SUITE 100  
 (858) 514-8377

**NOTE:**  
 THE CITY OF SAN DIEGO ENGINEER DOES NOT CONSTITUTE APPROVAL OF THIS SHEET AS IT ONLY REFLECTS IMPROVEMENTS LOCATED WITHIN CITY OF IMPERIAL BEACH JURISDICTION.

PRIVATE CONTRACT		<b>ELECTRICAL PLANS FOR:</b>	
		<b>IRIS RAPID CORRIDOR AND STATION DESIGN</b>	
		<b>IMPERIAL BEACH BLVD/CORONADO AVE</b>	
CITY OF IMPERIAL BEACH, CALIFORNIA		PROJECT NO. XXXXXX	
SHEET 27 OF 42 SHEETS		V.T.M.	
DESCRIPTION	BY	APPROVED	DATE FILMED
AS-BUILTS			
CONTRACTOR		DATE STARTED	
INSPECTOR		DATE COMPLETED	
		1786-6299 NAD83 COORDINATES	
		146-1739 LAMBERT COORDINATES	
		<b>27-D</b>	

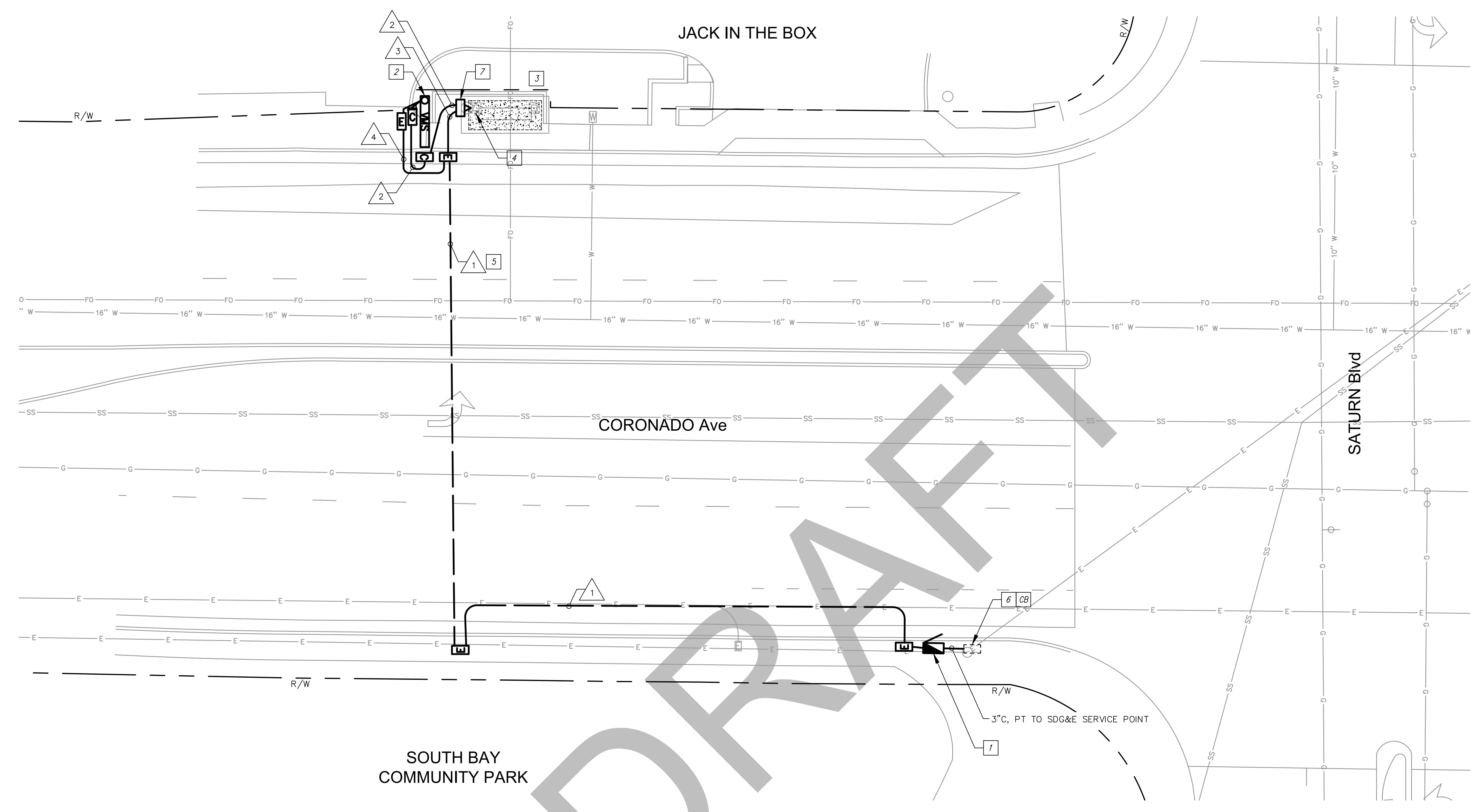

DRAFT

**CONSTRUCTION NOTES**

- 1 120/240V TYPE III-BF SINGLE METER SERVICE EQUIPMENT ENCLOSURE WITH THE FOLLOWING BREAKERS:  
 100A, 240V, 2P, CB - MAIN  
 20A, 120V, 1P, CB - SHELTER LIGHTING  
 20A, 120V, 1P, CB - SHELTER LIGHTING  
 20A, 120V, 1P, CB - VMS  
 20A, 120V, 1P, CB - VMS  
 20A, 120V, 1P, CB - MODEM  
 20A, 120V, 1P, CB - SPARE  
 20A, 120V, 1P, CB - SPARE
- 2 VARIABLE MESSAGE SIGN.
- 3 INSTALL WIRELESS MODEM ON BUS SHELTER.
- 4 INSTALL CONDUIT STUB OUTS IN BUS SHELTER FOUNDATION.
- 5 INSTALL CONDUIT BY HORIZONTAL DIRECTIONAL DRILLING.
- 6 EXISTING SDG&E HANDHOLE. COORDINATE WITH SDG&E FOR CONNECTION.
- 7 INSTALL No. 5 PULL BOX.

**CONDUIT NOTES**

- 1 2\"/>

**GENERAL NOTE**

1. CONTRACTOR IS TO CONFIRM AN APPROVED LOCATION FOR THE ELECTRICAL SERVICE METERS AND PEDESTALS PRIOR TO PLACEMENT.

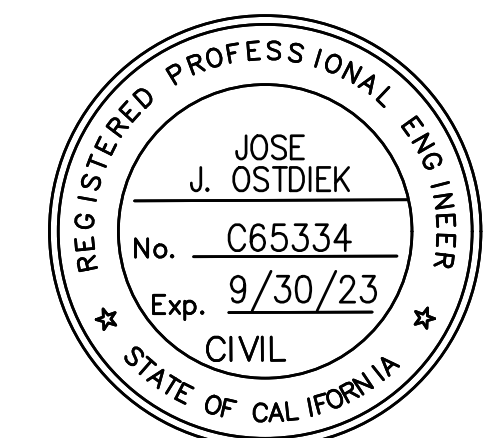

*Jose J. Ostdiek*  
 JOSE J. OSTDIEK R.C.E. NO. 65334 EXP. 09-30-23

DOKKEN ENGINEERING  
 1450 FRAZEE ROAD, SUITE 100  
 (858) 514-8377

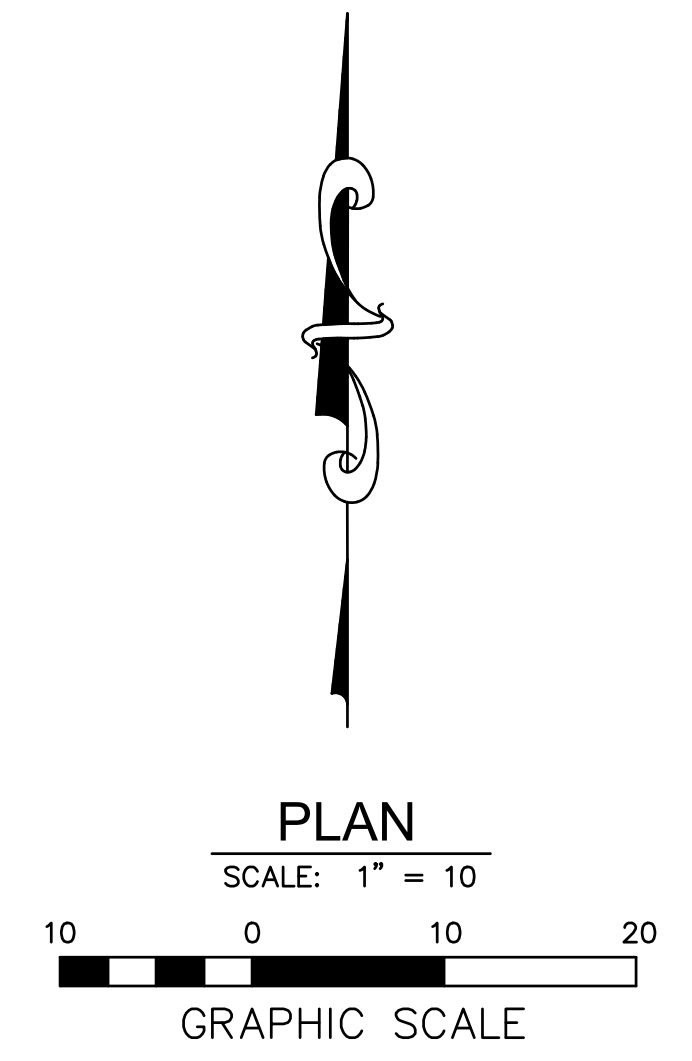

PRIVATE CONTRACT			
<b>ELECTRICAL PLANS FOR: IRIS RAPID CORRIDOR AND STATION DESIGN IMPERIAL BEACH BLVD/CORONADO AVE</b>			
CITY OF SAN DIEGO, CALIFORNIA DEVELOPMENT SERVICES DEPARTMENT SHEET 28 OF 42 SHEETS			PROJECT NO. XXXXXX
FOR CITY ENGINEER		DATE	
DESCRIPTION	BY	APPROVED	DATE FILMED
			V.T.M.
			1790-6299 NAD83 COORDINATES
			150-1739 LAMBERT COORDINATES
AS-BUILTS			
CONTRACTOR		DATE STARTED	
INSPECTOR		DATE COMPLETED	
<b>XXXXX-28-D</b>			

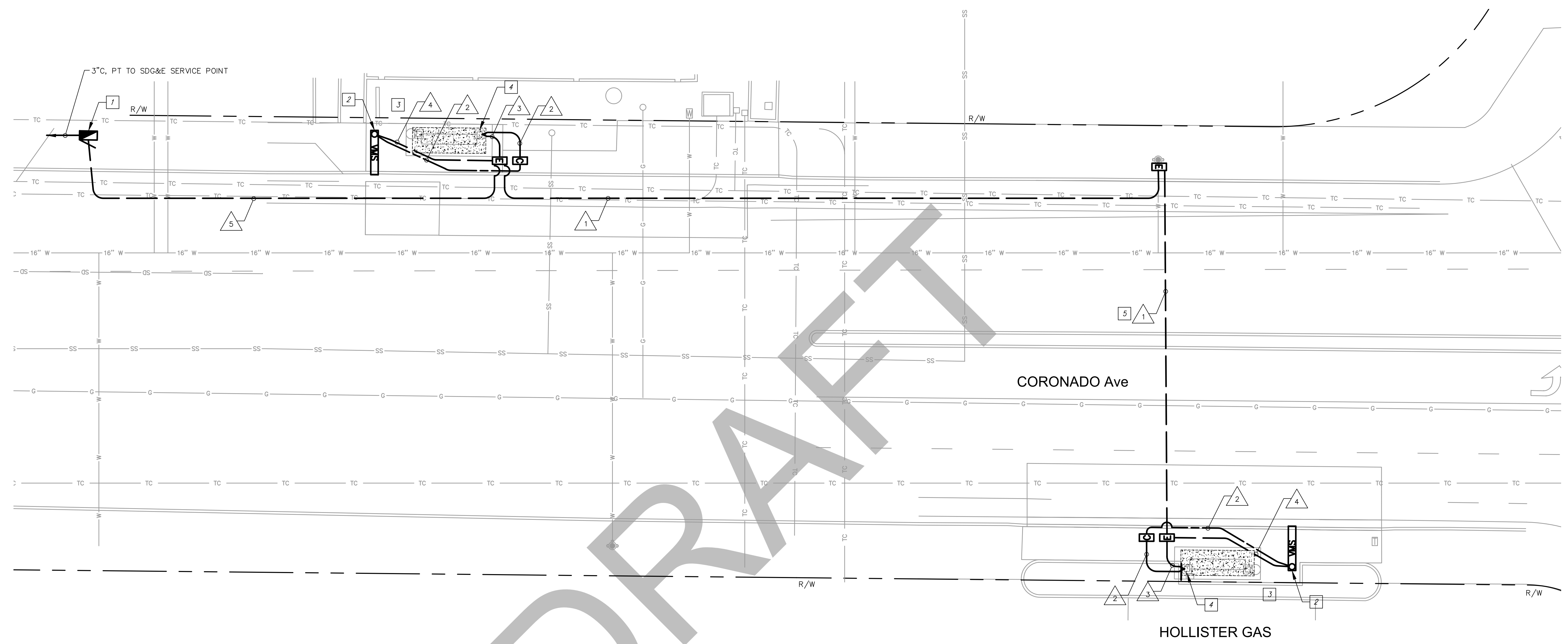

**CONSTRUCTION NOTES**

- 1 120/240V TYPE III-B SINGLE METER SERVICE EQUIPMENT ENCLOSURE WITH THE FOLLOWING BREAKERS:  
 100A, 240V, 2P, CB - MAIN  
 20A, 120V, 1P, CB - SHELTER LIGHTING  
 20A, 120V, 1P, CB - SHELTER LIGHTING  
 20A, 120V, 1P, CB - VMS  
 20A, 120V, 1P, CB - VMS  
 20A, 120V, 1P, CB - MODEM  
 20A, 120V, 1P, CB - SPARE  
 20A, 120V, 1P, CB - SPARE
- 2 VARIABLE MESSAGE SIGN.
- 3 INSTALL WIRELESS MODEM ON BUS SHELTER.
- 4 INSTALL CONDUIT STUB OUTS IN BUS SHELTER FOUNDATION.
- 5 INSTALL CONDUIT BY HORIZONTAL DIRECTIONAL DRILLING.

**CONDUIT NOTES**

- 1 2\"/>
- 2 2\"/>
- 3 2\"/>
- 4 2\"/>
- 5 2\"/>

**GENERAL NOTE**

1. CONTRACTOR IS TO CONFIRM AN APPROVED LOCATION FOR THE ELECTRICAL SERVICE METERS AND PEDESTALS PRIOR TO PLACEMENT.

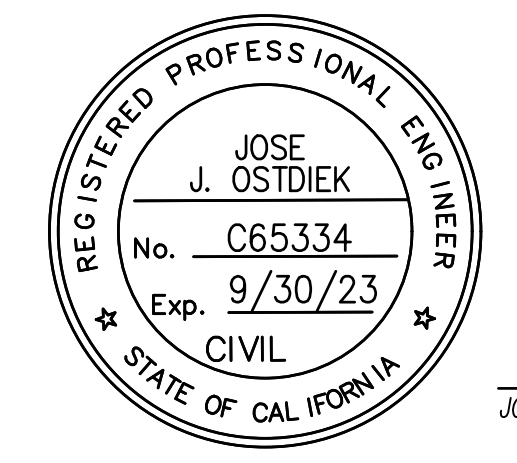

*Jose J. Ostdiek*  
 JOSE J. OSTDIEK R.C.E. NO. 65334 EXP. 09-30-23

DOKKEN ENGINEERING  
 1450 FRAZEE ROAD, SUITE 100  
 (858) 514-8377

DATE

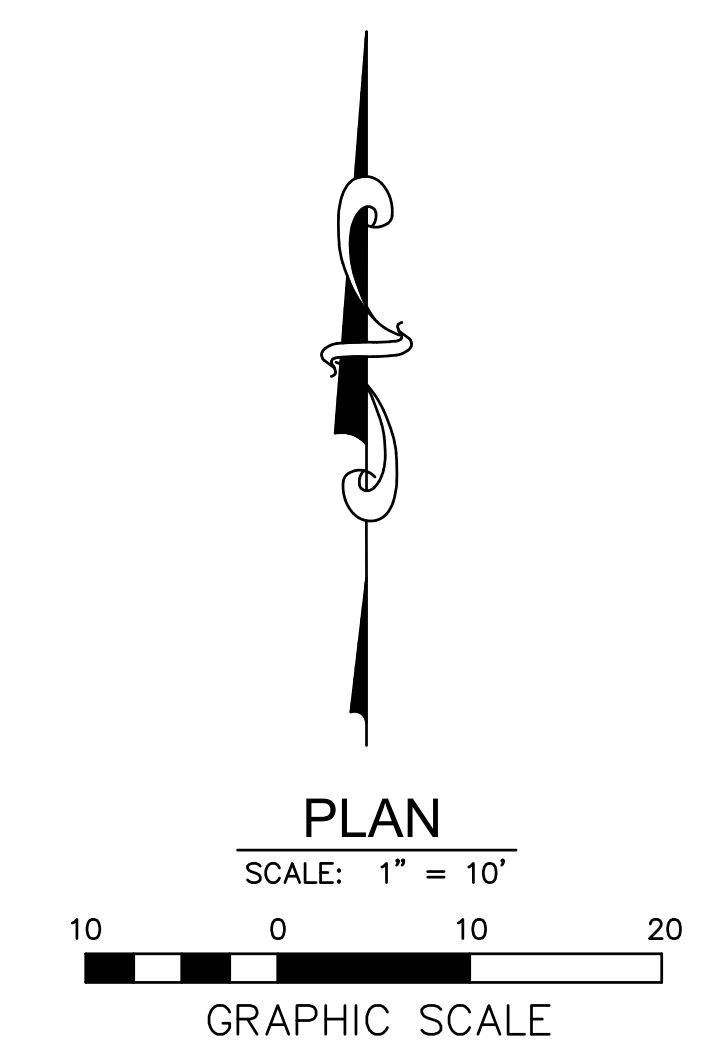

PRIVATE CONTRACT				PROJECT NO. XXXXXX	
ELECTRICAL PLANS FOR: <b>IRIS RAPID CORRIDOR AND STATION DESIGN</b> IMPERIAL BEACH BLVD/CORONADO AVE					
CITY OF SAN DIEGO, CALIFORNIA DEVELOPMENT SERVICES DEPARTMENT SHEET 29 OF 42 SHEETS				V.T.M.	
FOR CITY ENGINEER		DATE		V.T.M.	
DESCRIPTION	BY	APPROVED	DATE	FILMED	
AS-BUILTS					
CONTRACTOR				DATE STARTED	
INSPECTOR				DATE COMPLETED	
				1790-6303 NAD83 COORDINATES	
				150-1743 LAMBERT COORDINATES	
				XXXXX-29-D	



MATCH LINE (SEE BELOW)

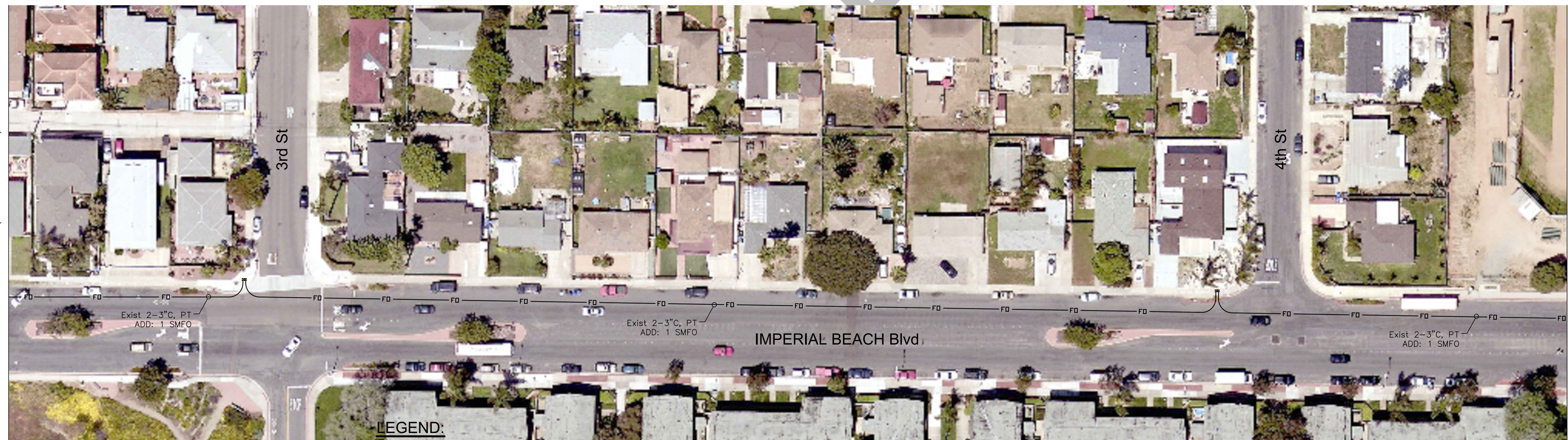
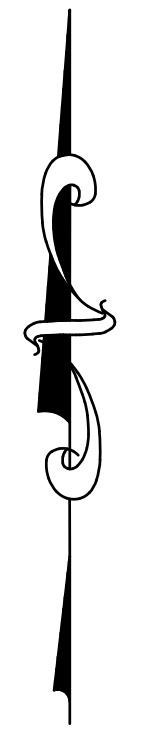

MATCH LINE (SEE ABOVE)

MATCH LINE (SHEET 31)

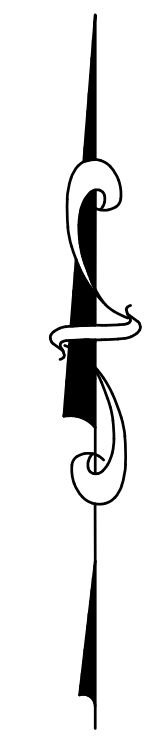

**LEGEND:**

**CONSTRUCTION NOTES**

- 1 EXISTING SPLICE VAULT TO REMAIN.

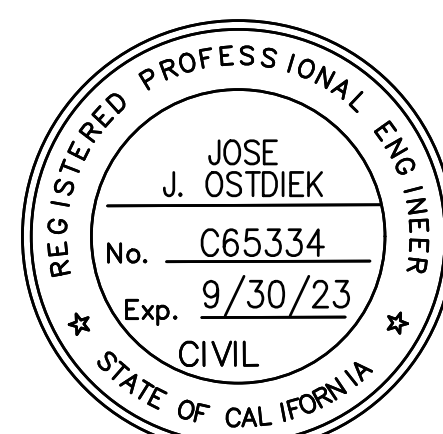
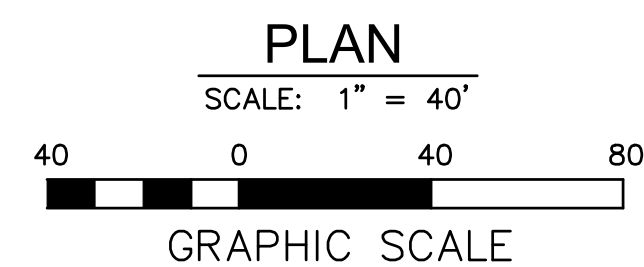

*Jose J. Ostdiek*  
 JOSE J. OSTDIEK R.C.E. NO. 65334 EXP. 09-30-23

DOKKEN ENGINEERING  
 1450 FRAZEE ROAD, SUITE 100  
 (858) 514-8377

**NOTE:**

THE CITY OF SAN DIEGO ENGINEER DOES NOT CONSTITUTE APPROVAL OF THIS SHEET AS IT ONLY REFLECTS IMPROVEMENTS LOCATED WITHIN CITY OF IMPERIAL BEACH JURISDICTION.

PRIVATE CONTRACT			
<b>FIBER OPTIC CABLE SYSTEMS FOR: IRIS RAPID CORRIDOR AND STATION DESIGN IMPERIAL BEACH BLVD/CORONADO AVE</b>			
CITY OF IMPERIAL BEACH, CALIFORNIA		PROJECT NO. XXXXXX	
SHEET 30 OF 42 SHEETS		V.T.M.	
DESCRIPTION	BY	APPROVED	DATE FILMED
AS-BUILTS			
CONTRACTOR		DATE STARTED	
INSPECTOR		DATE COMPLETED	
			<b>30-D</b>



**CONSTRUCTION NOTES**  
 1 EXISTING SPLICE VAULT TO REMAIN.

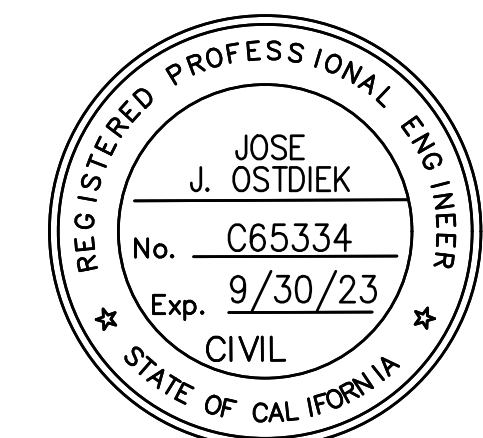
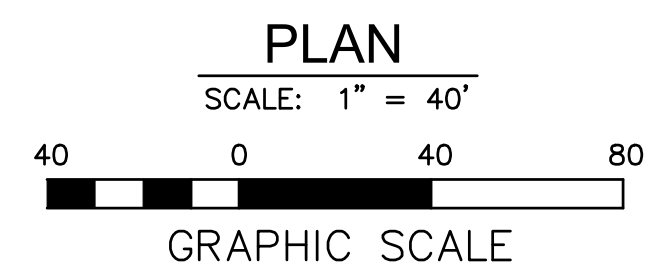

*Jose J. Ostdiek*  
 JOSE J. OSTDIEK R.C.E. NO. 65334 EXP. 09-30-23 DATE

DOKKEN ENGINEERING  
 1450 FRAZEE ROAD, SUITE 100  
 (858) 514-8377

**NOTE:**  
 THE CITY OF SAN DIEGO ENGINEER DOES NOT CONSTITUTE APPROVAL OF THIS SHEET AS IT ONLY REFLECTS IMPROVEMENTS LOCATED WITHIN CITY OF IMPERIAL BEACH JURISDICTION.

PRIVATE CONTRACT			
FIBER OPTIC CABLE SYSTEMS FOR <b>IRIS RAPID CORRIDOR AND STATION DESIGN</b> IMPERIAL BEACH BLVD/CORONADO AVE			
CITY OF IMPERIAL BEACH, CALIFORNIA		PROJECT NO. XXXXXX	
SHEET 31 OF 42 SHEETS		V.T.M.	
DESCRIPTION	BY	APPROVED	DATE FILMED
AS-BUILTS			
CONTRACTOR	DATE STARTED		
INSPECTOR	DATE COMPLETED		
		1786-6299 NAD83 COORDINATES	
		146-1739 LAMBERT COORDINATES	
			<b>31-D</b>



LEGEND:

CONSTRUCTION NOTES

- 1 EXISTING SPLICE VAULT TO REMAIN.

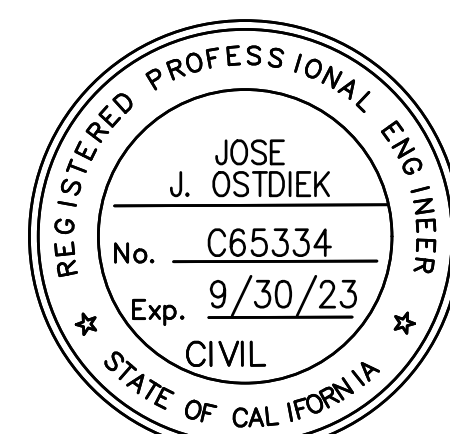
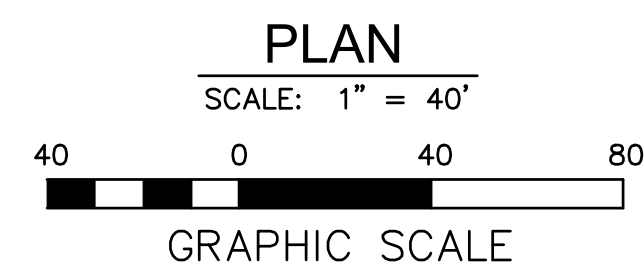

*Jose J. Ostdiek*  
JOSE J. OSTDIEK R.C.E. NO. 65334 EXP. 09-30-23

DOKKEN ENGINEERING  
1450 FRAZEE ROAD, SUITE 100  
(858) 514-8377

**NOTE:**  
THE CITY OF SAN DIEGO ENGINEER DOES NOT CONSTITUTE APPROVAL OF THIS SHEET AS IT ONLY REFLECTS IMPROVEMENTS LOCATED WITHIN CITY OF IMPERIAL BEACH JURISDICTION.

PRIVATE CONTRACT			
FIBER OPTIC CABLE SYSTEMS FOR: <b>IRIS RAPID CORRIDOR AND STATION DESIGN</b> IMPERIAL BEACH BLVD/CORONADO AVE			
CITY OF IMPERIAL BEACH, CALIFORNIA		PROJECT NO. XXXXXX	
SHEET 32 OF 42 SHEETS		V.T.M.	
DESCRIPTION	BY	APPROVED	DATE FILMED
AS-BUILTS			
CONTRACTOR		DATE STARTED	
INSPECTOR		DATE COMPLETED	
			<b>32-D</b>



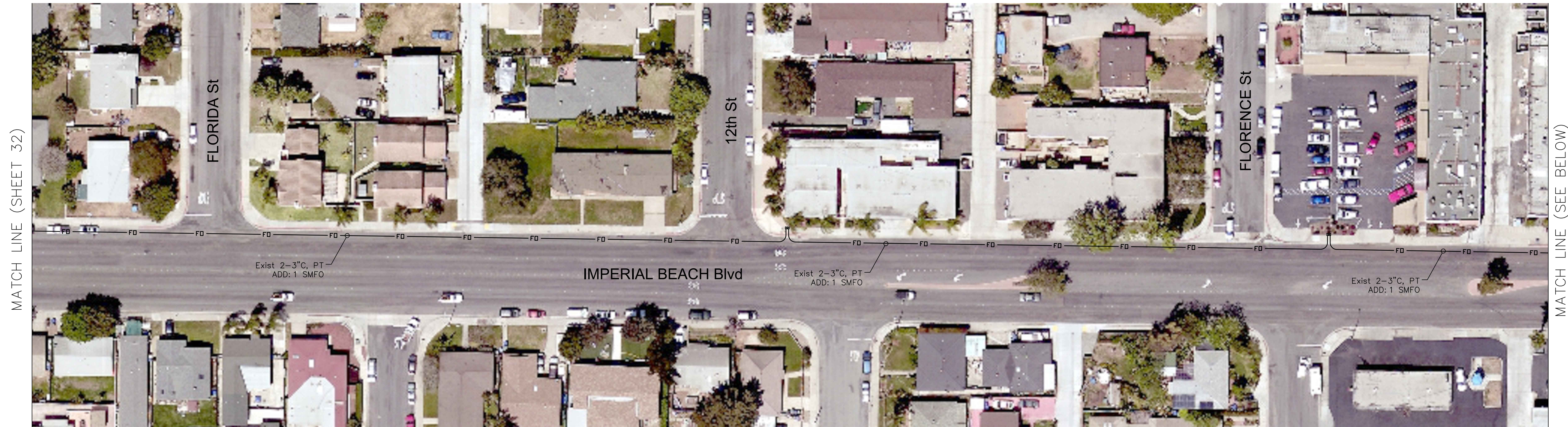

LEGEND:

**CONSTRUCTION NOTES**

- 1 EXISTING SPLICE VAULT TO REMAIN.

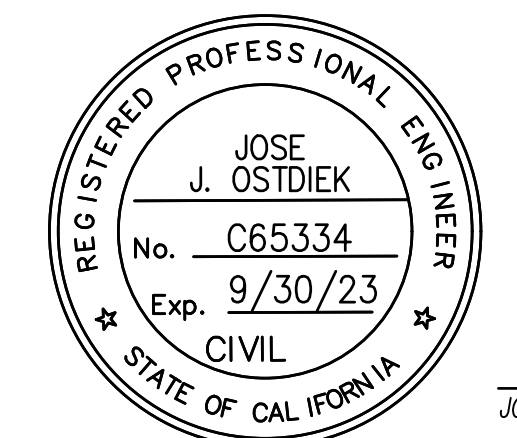
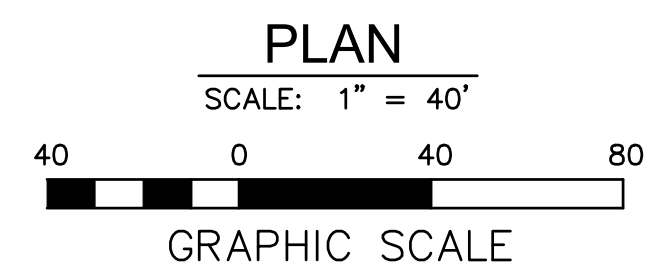

JOSE J. OSTDIEK R.C.E. NO. 65334 EXP. 09-30-23 DATE

DOKKEN ENGINEERING  
 1450 FRAZEE ROAD, SUITE 100  
 (858) 514-8377

**NOTE:**  
THE CITY OF SAN DIEGO ENGINEER DOES NOT CONSTITUTE APPROVAL OF THIS SHEET AS IT ONLY REFLECTS IMPROVEMENTS LOCATED WITHIN CITY OF IMPERIAL BEACH JURISDICTION.

PRIVATE CONTRACT <b>FIBER OPTIC CABLE SYSTEMS FOR:                  IRIS RAPID CORRIDOR                  AND STATION DESIGN</b> IMPERIAL BEACH BLVD/CORONADO AVE			
CITY OF IMPERIAL BEACH, CALIFORNIA SHEET 33 OF 42 SHEETS		PROJECT NO. XXXXXX V.T.M.	
DESCRIPTION	BY	APPROVED	DATE FILMED
AS-BUILTS			
CONTRACTOR		DATE STARTED	
INSPECTOR		DATE COMPLETED	
1786-6299 NAD83 COORDINATES 146-1739 LAMBERT COORDINATES			<b>33-D</b>

**GENERAL NOTES**

1. EXISTING WIRING IS ONLY SHOWN FOR THE IMPACTED AREAS OF THIS PROJECT.
2. ALL NEW PULL BOXES SHALL BE No. 5 WITH LOCKABLE LIDS.

**CONSTRUCTION NOTES**

- 1 CONTRACTOR TO INSTALL VARIABLE MESSAGE SIGN AND CCTV. VARIABLE MESSAGE SIGN AND CCTV FURNISHED BY OTHERS.
- 2 EXISTING BUS PLATFORM LIGHT
- 3 CONDUIT STUB IN FOUNDATION FOR FUTURE VARIABLE MESSAGE SIGN

**CONDUIT NOTES**

- |   |  |  |
|---|--|--|
| 1 Exist 1" C, 2#10 (Ltg) (B:10/12), 1#10 (G)  | 5 2" C, 2#10 (VMS) (C:24), 1#8 (G)                                 | 9 Exist 1" C, 2#10 (Ltg) (B:1/3), 1#10 (G) |
| 2 Exist 2" C, COMMUNICATION                   | 6 2" C, 2 CAT6 (VMS), 1 CAT6 (CCTV)                                | 10 Exist 2-3" C, COMMUNICATION             |
| 3 2" C, PT                                    | 7 Exist 2-3" C, 2#10 (B:1/3) (Ltg), 2#10 (B:10/12) (Ltg), 1#10 (G) | 11 Exist 2-3" C, POWER                     |
| 4 Exist 2-3" C, POWER; ADD: 2#10 (VMS) (C:24) | 8 Exist 2-3" C, COMMUNICATION; ADD: 2 CAT6 (VMS), 1 CAT6 (CCTV)    | 12 Exist 2-3" C, COMMUNICATION             |

**IRIS TRANSIT CENTER EAST**  
**APN 630-321-17**  
**LOT 11, MAP 9557**

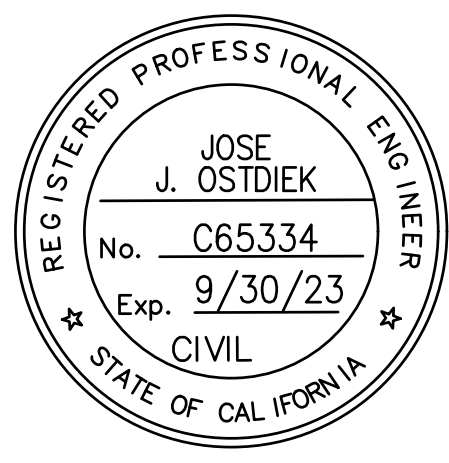
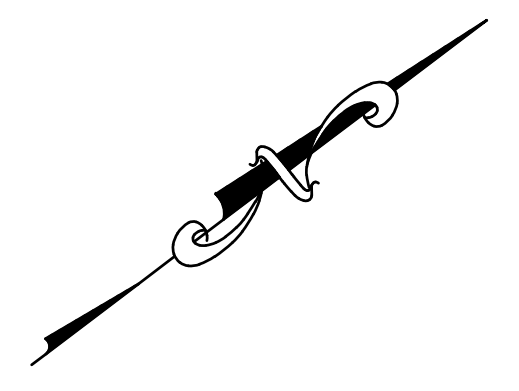
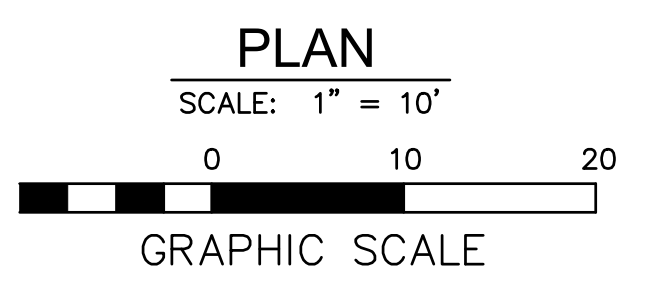
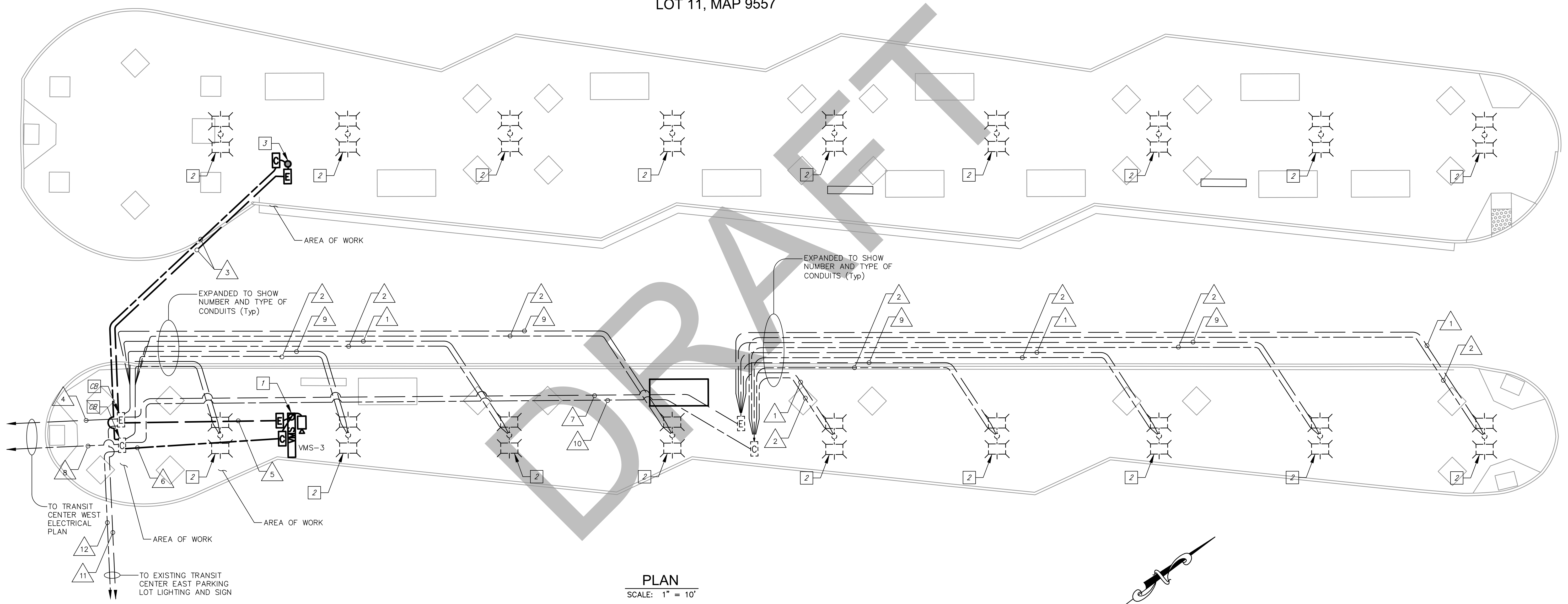

*Jose J. Ostdiek*  
 JOSE J. OSTDIEK R.C.E. NO. 65334 EXP. 09-30-23

DOKKEN ENGINEERING  
 1450 FRAZEE ROAD, SUITE 100  
 (858) 514-8377

DATE \_\_\_\_\_

PRIVATE CONTRACT			
<b>ELECTRICAL PLANS FOR: IRIS RAPID CORRIDOR AND STATION DESIGN IRIS AVENUE TRANSIT CENTER EAST</b>			
CITY OF SAN DIEGO, CALIFORNIA DEVELOPMENT SERVICES DEPARTMENT SHEET 34 OF 42 SHEETS			PROJECT NO. XXXXXX
FOR CITY ENGINEER	DATE	V.T.M.	
DESCRIPTION	BY	APPROVED	DATE FILMED
AS-BUILTS	DATE STARTED	1786-6307	NAD83 COORDINATES
CONTRACTOR	DATE COMPLETED	146-1747	LAMBERT COORDINATES
INSPECTOR		<b>XXXXX-34-D</b>	

EXISTING CONDUCTOR AND CONDUIT SCHEDULE (BEYER)

Table with columns: CABLE SCHEDULE, CONDUIT RUN NUMBER AND SIZE, AWG OR CABLE TYPE, PHASE OR CIRCUIT, and 5 columns of conductor counts.

PROPOSED CONDUCTOR AND CONDUIT SCHEDULE (30th St)

Table with columns: CABLE SCHEDULE, CONDUIT RUN NUMBER AND SIZE, and 11 columns of conductor counts.

POLE AND EQUIPMENT SCHEDULE

Table with columns: No., STANDARD, LUMINAIRE, PLACEMENT, SIGNAL MOUNTING, PEDESTRIAN, STREET NAME SIGN, and REMARKS.

CONSTRUCTION NOTES (THIS SHEET ONLY):

- 1 REPLACE EXISTING CONTROLLER ASSEMBLY...
2 EXISTING STREET LIGHT POLE TO BE REMOVED.
3 INSTALL STREET NAME SIGN ON SIGNAL STANDARD.
...
16 RC EXISTING PULL BOX, INSTALL #6 PULL BOX.

DETECTOR SCHEDULE

Table with columns: No., PHASE, SLOT, TERMINAL, and 4 columns of terminal assignments.

POLE AND DETECTOR LOOP PLACEMENT DETAIL (NO SCALE)

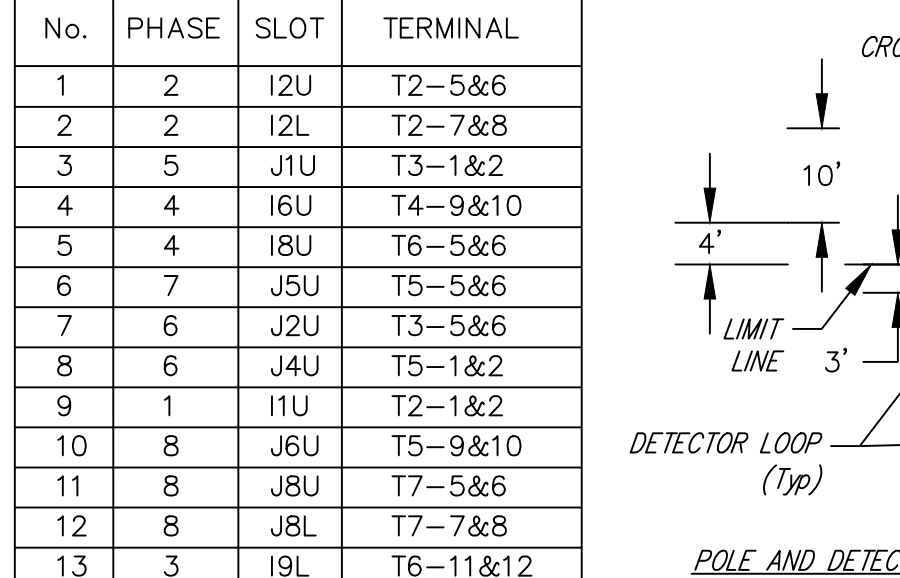

EXIST PHASE DIAGRAM (BEYER Blvd)

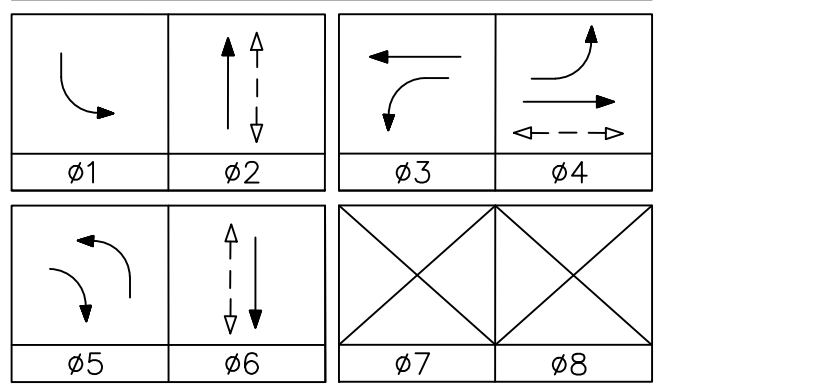

PROPOSED PHASE DIAGRAM (BEYER Blvd)

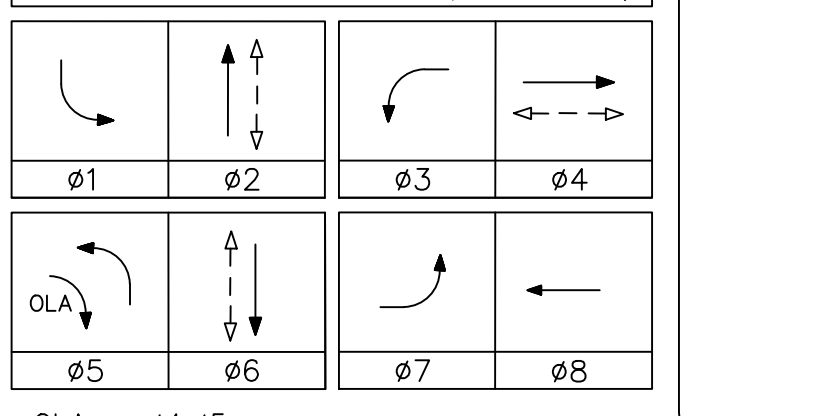

PROPOSED PHASE DIAGRAM (30th St)

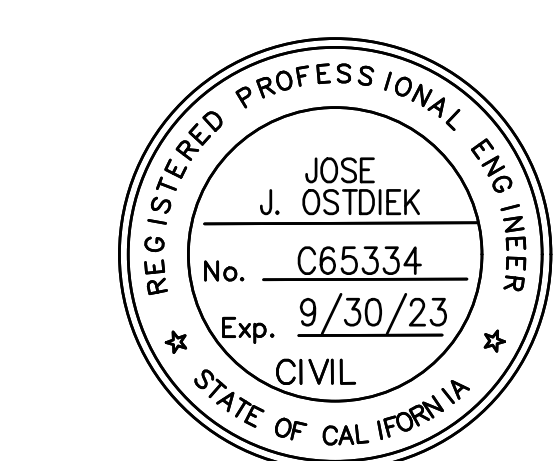
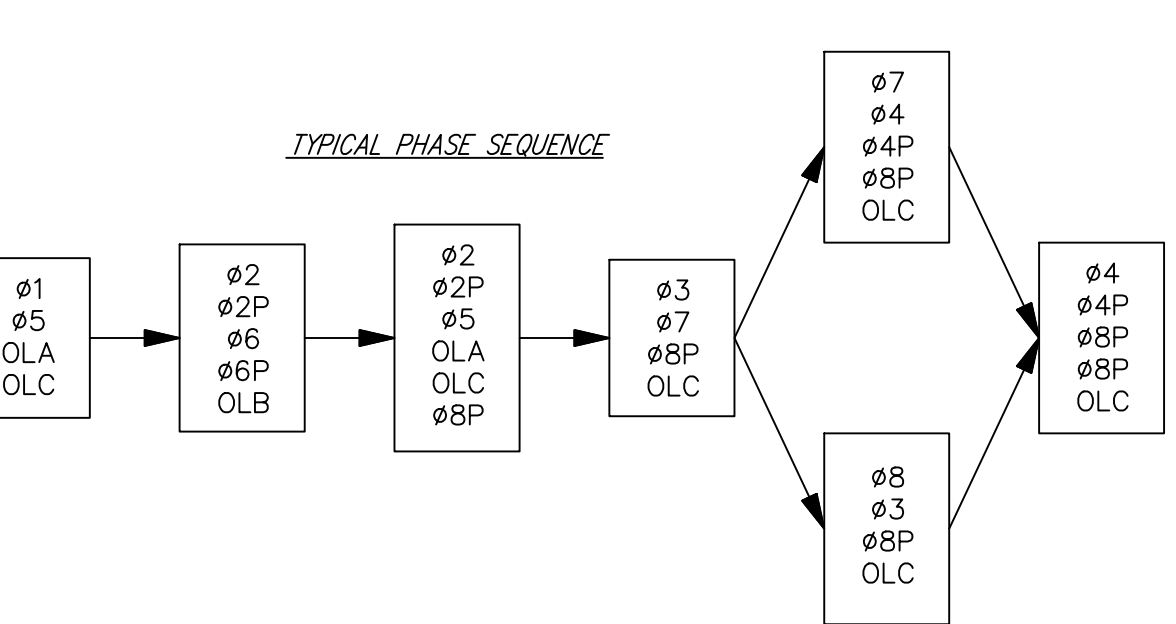
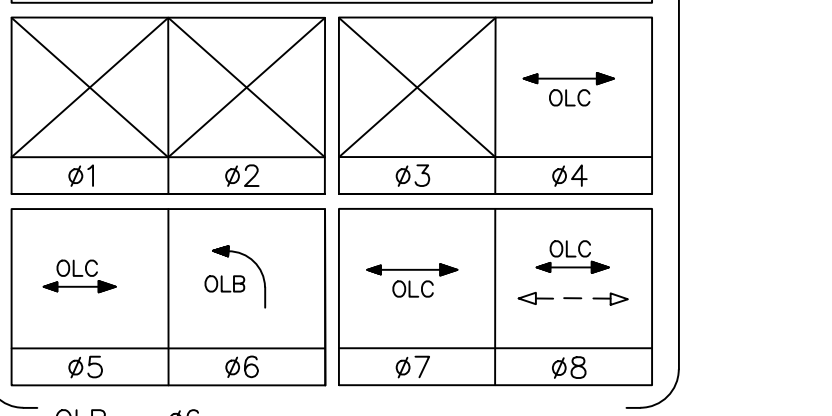

JOSE J. OSTDIEK R.C.E. NO. 65334 EXP. 09-30-23 DATE

DOKKEN ENGINEERING 1450 FRAZEE ROAD, SUITE 100 (858) 514-8377

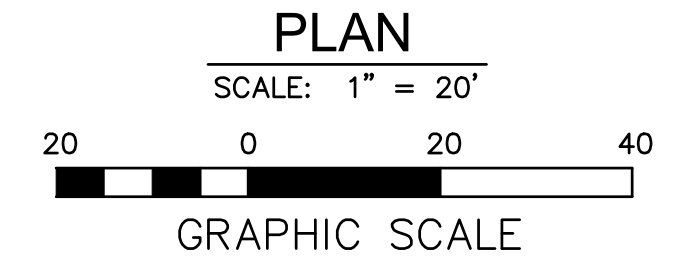
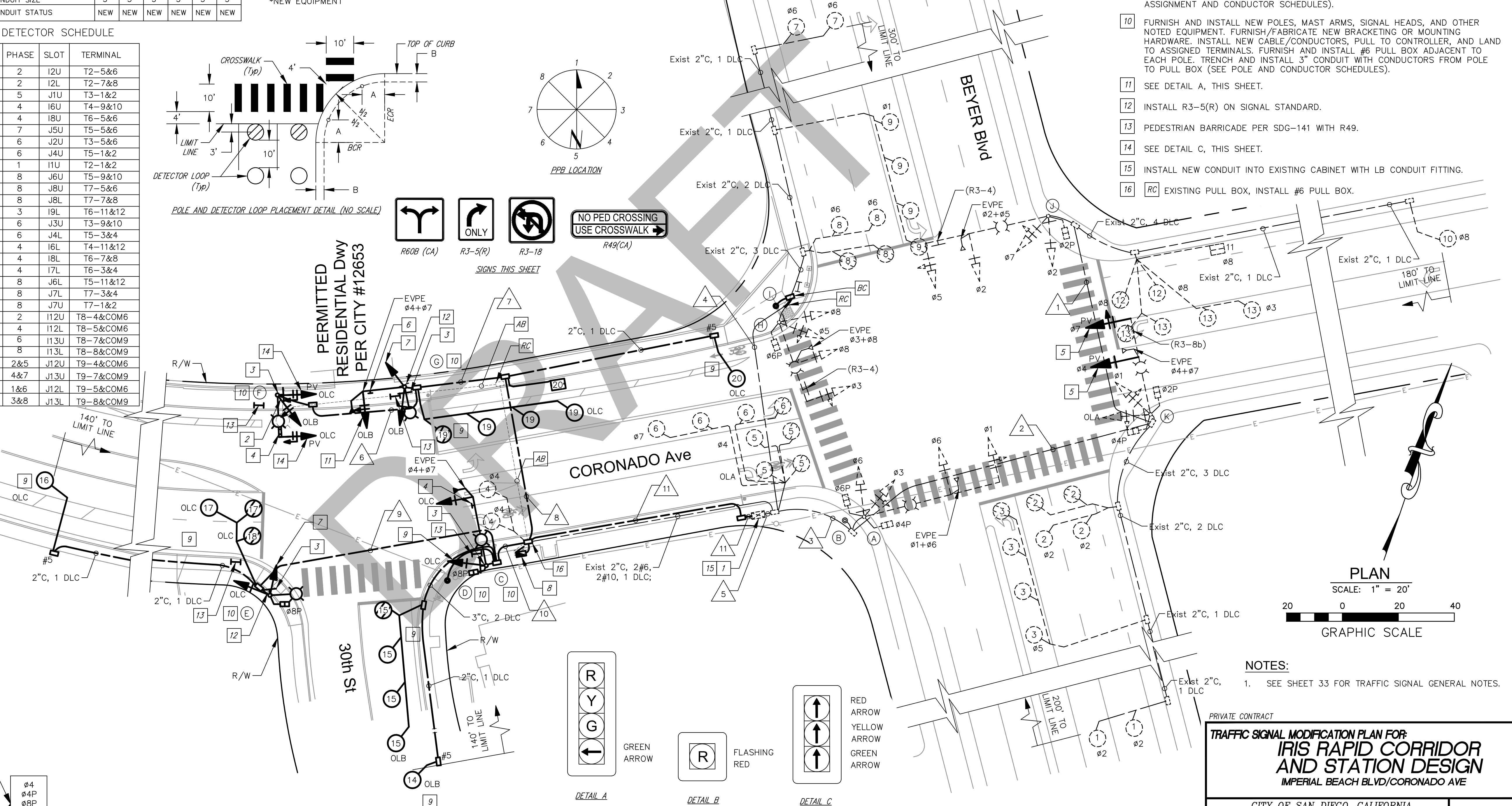

NOTES: 1. SEE SHEET 33 FOR TRAFFIC SIGNAL GENERAL NOTES.

TRAFFIC SIGNAL MODIFICATION PLAN FOR IRIS RAPID CORRIDOR AND STATION DESIGN IMPERIAL BEACH BLVD/CORONADO AVE. Includes project info, city of San Diego, and contractor details.

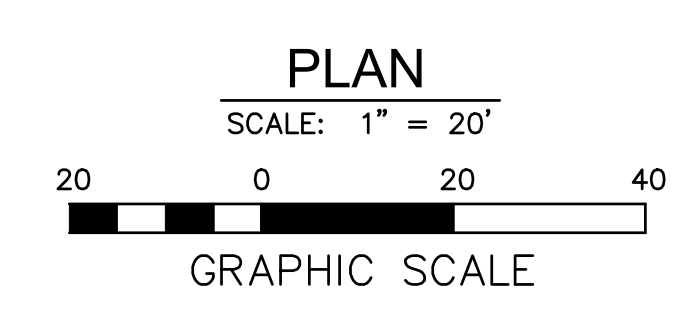
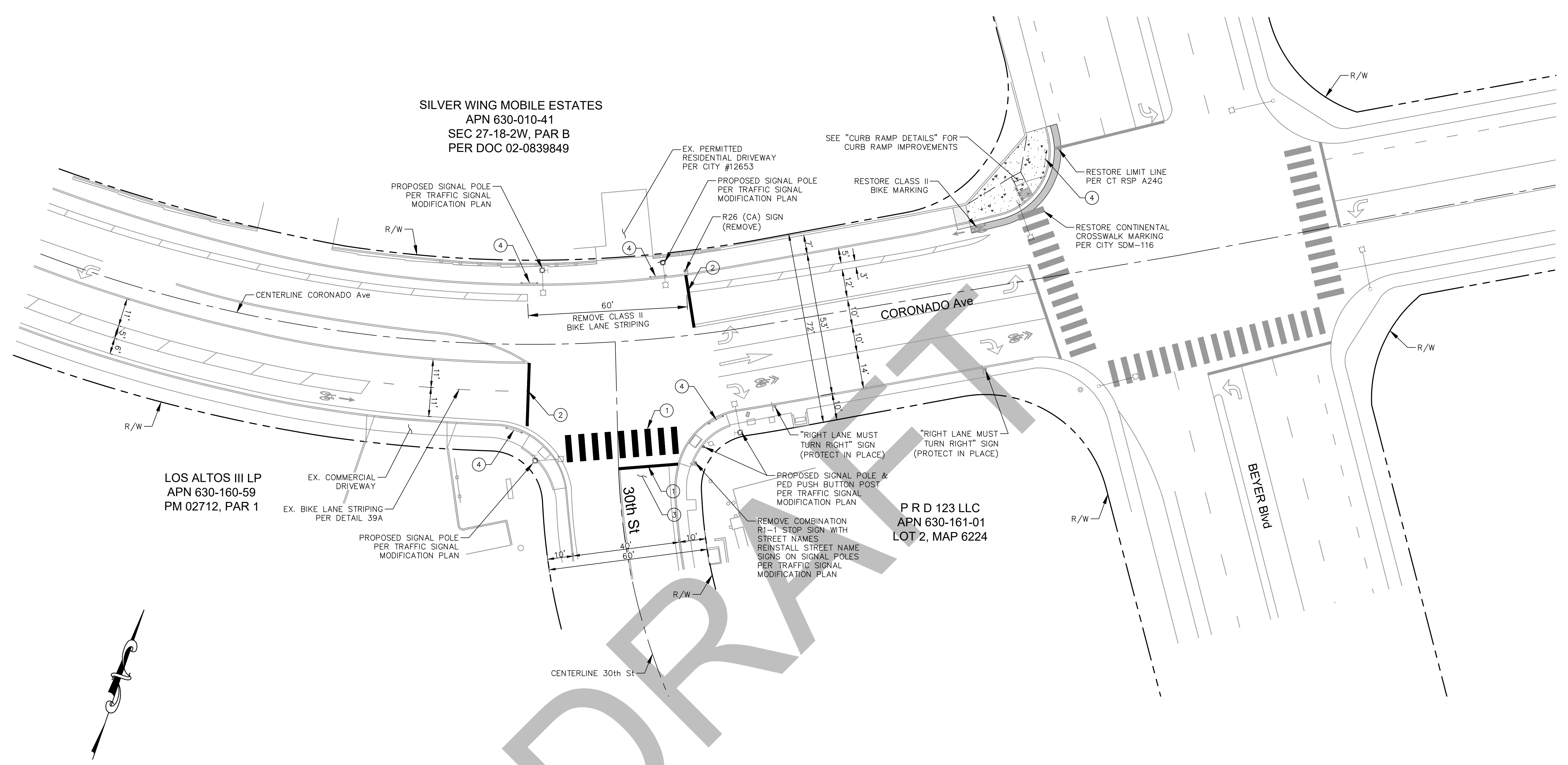

**STRIPING & PAVEMENT MARKING NOTES:**

- ① CONTINENTAL CROSSWALK AND LIMIT LINE PER SDM-116
- ② LIMIT LINE PER CSP A24E
- ③ REMOVE EXISTING LIMIT LINE AND "STOP" PAVEMENT MARKING
- ④ INSTALL TYPE A PEDESTRIAN BARRICADE PER SDG-141 SET 4-FT MIN. FROM BACK OF WALK

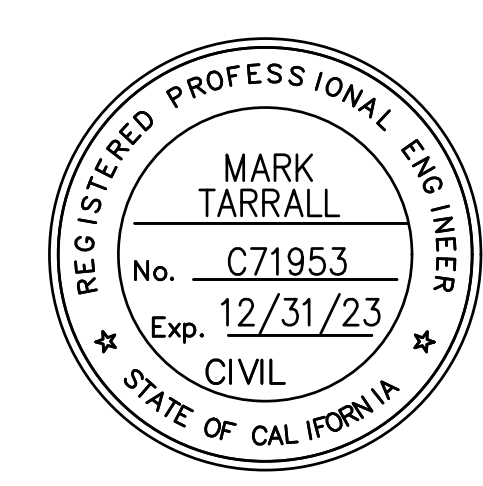

*Mark Tarrall*  
 MARK TARRALL R.C.E. NO. 71953 EXP. 12-31-23

DOKKEN ENGINEERING  
 1450 FRAZEE ROAD, SUITE 100  
 (858) 514-8377

DATE \_\_\_\_\_

PRIVATE CONTRACT

**SIGNING AND STRIPING PLANS FOR  
 IRIS RAPID CORRIDOR  
 AND STATION DESIGN  
 IMPERIAL BEACH BLVD/CORONADO AVE**

CITY OF SAN DIEGO, CALIFORNIA DEVELOPMENT SERVICES DEPARTMENT SHEET 36 OF 42 SHEETS		PROJECT NO. XXXXXX
FOR CITY ENGINEER	DATE	V.T.M.
DESCRIPTION	BY	APPROVED
		DATE
		FILMED
AS-BUILTS		1790-6307 NAD83 COORDINATES
		150-1747 LAMBERT COORDINATES
CONTRACTOR	DATE STARTED	
INSPECTOR	DATE COMPLETED	

XXXXX-36-D



**KEYMAP**  
NOT TO SCALE

- NOTES:**
- ALL EXISTING IMPROVEMENTS WITHIN THE PROJECT LIMITS (A/C DIKE, SIDEWALK) SHALL BE REMOVED.
  - ALL SHOWN EXISTING UTILITIES SHALL BE ADJUSTED TO GRADE UNLESS OTHERWISE NOTED.

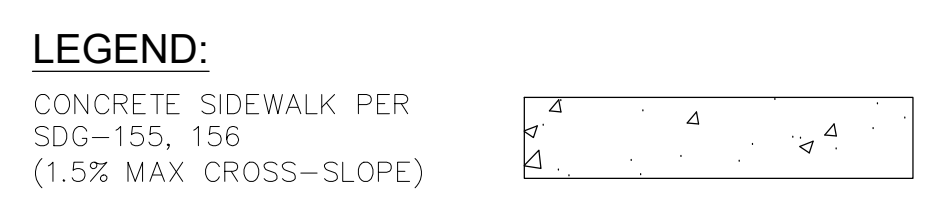

- CONSTRUCTION NOTES:**
- 6" CURB & GUTTER PER SDG-151
  - TYPE A CURB RAMP PER SDG-132
  - INSTALL 8" CURB & PROTECTIVE RAILING PER SDG-140

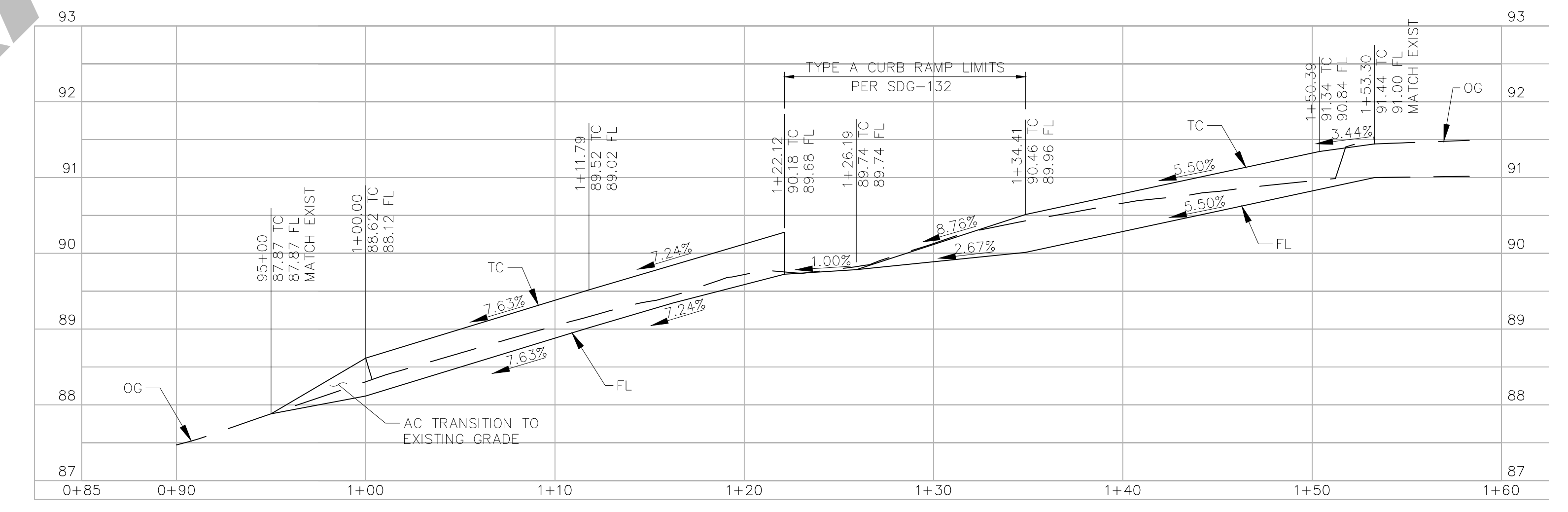
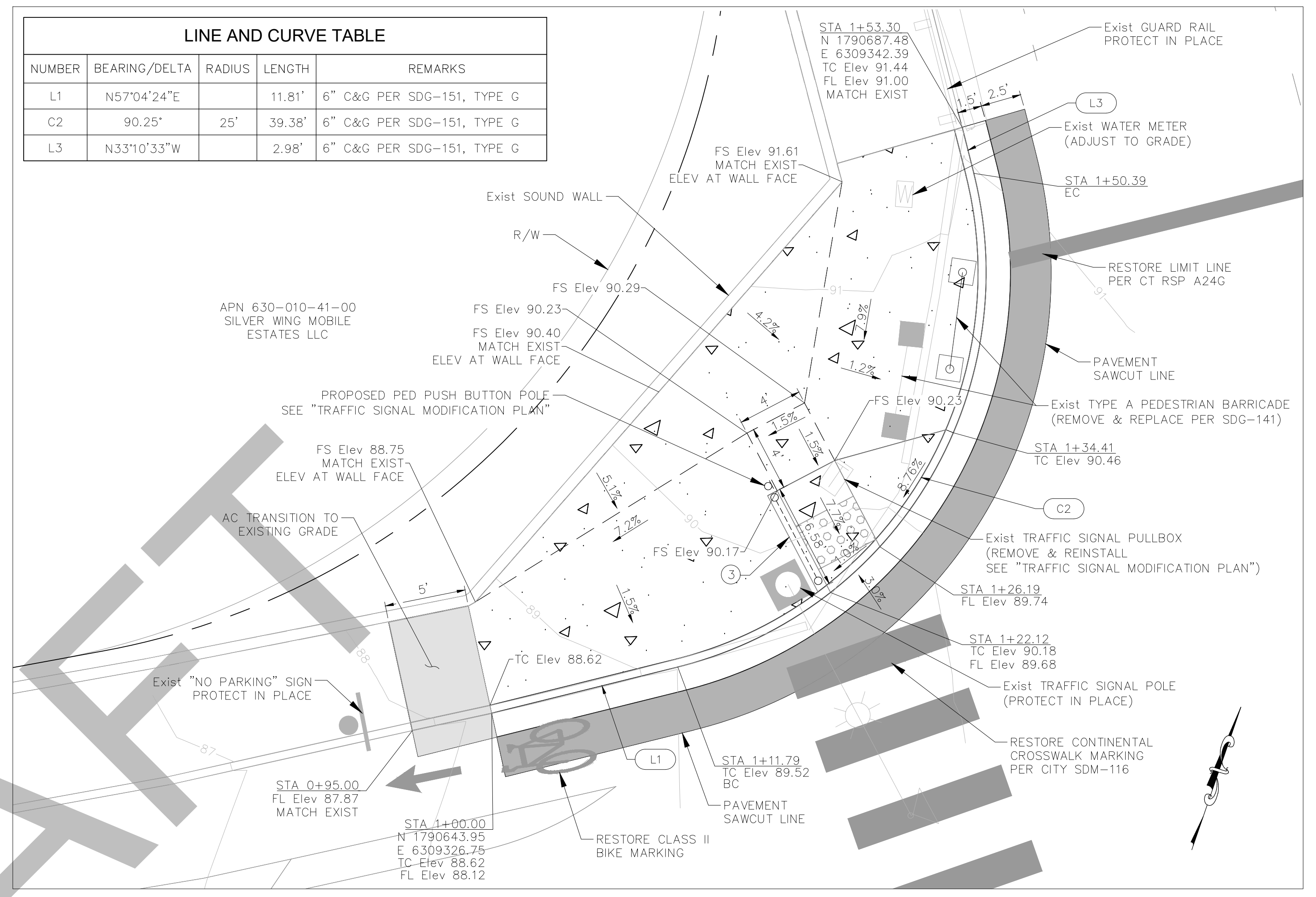
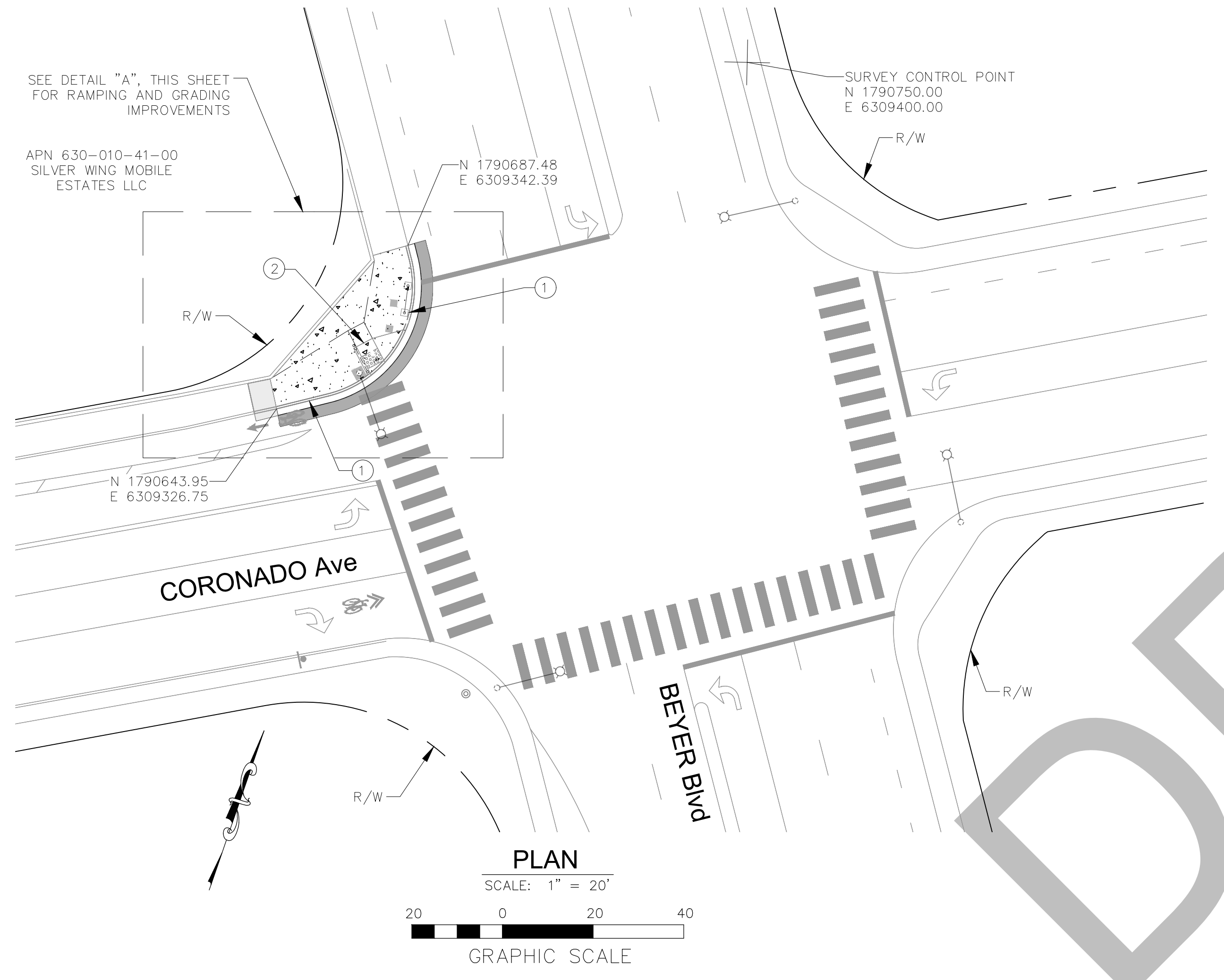

**BASIS OF COORDINATES: (NAD83)**  
THE BASIS OF COORDINATES FOR THIS SURVEY IS THE NORTH AMERICAN DATUM OF 1983 (NAD 83) CALIFORNIA STATE PLANE COORDINATE SYSTEM OF 1983 (CCS83) ZONE 6, 1991.35' EPOCH, BASED LOCALLY UPON THE FOLLOWING FIRST ORDER CONTROL POINTS PER RECORD OF SURVEY 14492 AND RECORD OF SURVEY 17055:

STATION	NORTHING	EASTING	DESCRIPTION
190	1783831.44	6317394.05	CALTRANS BD. "805-1.1 1992" IN CENTER OF BEYER BLVD BRIDGE OVER I-805

GRID BEARING BETWEEN 190 AND 56 = N 69°33'33" W.

**VERTICAL CONTROL: (NAVD88)**  
ELEVATIONS SHOWN HERE ON ARE IN TERMS OF THE NORTH AMERICAN DATUM OF 1988 (NAVD88) BASED LOCALLY UPON THE FOLLOWING CONTROL POINT PER ROS 14492 AND NGS DATA SHEET.

BENCHMARK	ELEVATION	DESCRIPTION
59	56.69'	BRASS DISC, F 1412 1997, NE CORNER OF CORONADO AVE. BRIDGE OVER I-5.



*Mark Tarrall*  
MARK TARRALL R.C.E. NO. 71953 EXP. 12-31-23

DOKKEN ENGINEERING  
1450 FRAZEE ROAD, SUITE 100  
(858) 514-8377

DATE

PRIVATE CONTRACT

**CURB RAMP DETAILS FOR:**  
**IRIS RAPID CORRIDOR AND STATION DESIGN**  
IMPERIAL BEACH BLVD/CORONADO AVE

CITY OF SAN DIEGO, CALIFORNIA DEVELOPMENT SERVICES DEPARTMENT SHEET 37 OF 42 SHEETS		PROJECT NO. XXXXXX
FOR CITY ENGINEER	DATE	V.T.M.
DESCRIPTION	BY	APPROVED
		DATE
		FILMED
AS-BUILTS		
CONTRACTOR	DATE STARTED	1790-6307 NAD83 COORDINATES
INSPECTOR	DATE COMPLETED	150-1747 LAMBERT COORDINATES
		XXXXX-37-D

**TRAFFIC CONTROL NOTES:**

- VALIDATION. THIS TRAFFIC CONTROL PLAN IS NOT VALID UNTIL WORK DATES ARE APPROVED. THE CONTRACTOR SHALL, PER SECTION 601-2 OF THE CITY SUPPLEMENT TO THE STANDARD SPECIFICATIONS FOR PUBLIC WORKS CONSTRUCTION, CONTACT THE PUBLIC WORKS TRAFFIC CONTROL SECTION AT (858) 495-4742 TO OBTAIN A PERMIT. THE CONTRACTOR MUST SUBMIT A COMPLETED TRAFFIC CONTROL PERMIT FORM A MINIMUM OF TWO (2) WORKING DAYS PRIOR TO STARTING WORK, OR FIVE (5) WORKING DAYS WHEN THE WORK WILL AFFECT A TRAFFIC SIGNAL.
- STANDARDS. THIS TRAFFIC CONTROL PLAN SHALL CONFORM TO EACH OF THE FOLLOWING MANUALS:
 

DOCUMENT NO.	EDITION	DESCRIPTION
PWP1010119-01	2018	STANDARD SPECIFICATIONS FOR PUBLIC WORKS CONSTRUCTION ("GREENBOOK")
PWP1010119-02	2018	CITY OF SAN DIEGO SUPPLEMENT TO THE "GREENBOOK" ("WHITEBOOK")
PWP1010119-03	2018	CITY OF SAN DIEGO STANDARD DRAWINGS
PWP1092816-08	2014	CALIFORNIA MANUAL ON UNIFORM TRAFFIC CONTROL DEVICES (CA MUTCD)
- NOTIFICATIONS. THE CONTRACTOR SHALL NOTIFY THE FOLLOWING AFFECTED AGENCIES A MINIMUM OF FIVE (5) WORKING DAYS PRIOR TO ANY EXCAVATION, CONSTRUCTION, OR TRAFFIC CONTROL:
 

FIRE DEPARTMENT DISPATCH	(STREET OR ALLEY CLOSURE)	(858) 573-1300
POLICE DEPARTMENT DISPATCH	(STREET OR ALLEY CLOSURE)	(858) 531-2000
ENVIRONMENTAL SERVICES	(REFUSE COLLECTION)	(858) 492-5060
STREET DIVISION / ELECTRICAL	(TRAFFIC SIGNALS)	(619) 527-7500
METROPOLITAN TRANSIT SYSTEM	(BUS STOPS)	(619) 595-7038 EXT 64
METROPOLITAN TRANSIT SYSTEM	(TAXI ZONES)	(619) 235-2644
METROPOLITAN TRANSIT SYSTEM	(TROLLEY LINES)	(619) 595-4960
UNDERGROUND SERVICE ALERT	(ANY EXCAVATION)	(800) 422-4133
- THE CONTRACTOR SHALL NOTIFY PROPERTY OWNERS AND TENANTS A MINIMUM OF FIVE (5) WORKING DAYS PRIOR TO CLOSURE OF DRIVEWAYS. THE CONTRACTOR SHALL POST SIGNS NOTIFYING THE PUBLIC A MINIMUM OF FIVE (5) WORKING DAYS PRIOR TO CLOSURE OF STREETS.
- POSTING NO PARKING SIGNS. THE CONTRACTOR SHALL POST "TOW-AWAY/NO PARKING" SIGNS SEVENTY-TWO (72) HOURS IN ADVANCE FOR TEMPORARY PARKING REMOVAL. SIGNS SHALL INDICATE SPECIFIC DAYS, DATES, AND TIMES OF RESTRICTIONS.
- EXCAVATIONS. EXCEPT AS OTHERWISE SHOWN ON THE PLANS, TRENCHES SHALL BE BACKFILLED OR TRENCH-PLATED AT THE END OF EACH WORK DAY. AN ASPHALT RAMP SHALL BE PLACED AROUND EACH TRENCH PLATE TO PREVENT THE PLATE FROM BEING DISLODGED. CONTRACTOR SHALL MONITOR TRENCH PLATES DURING NON-WORKING HOURS TO ENSURE THEY DO NOT BECOME DISLODGED. UPON COMPLETION OF EXCAVATION BACKFILL, THE CONTRACTOR SHALL PROVIDE A SATISFACTORY SURFACE FOR TRAFFIC. WHEN CONSTRUCTION OPERATIONS ARE NOT ACTIVELY IN PROGRESS, THE CONTRACTOR SHALL MAINTAIN ALL TRAVEL LANES, BIKE LANES, AND PEDESTRIAN WALKWAYS OPEN TO APPROPRIATE TRAFFIC, EXCEPT AS OTHERWISE SHOWN ON THE PLANS.
- RESTORATION OF TRAFFIC CONTROL DEVICES. THE CONTRACTOR SHALL REPAIR OR REPLACE TRAFFIC CONTROL DEVICES (INCLUDING TRAFFIC SIGNS, STRIPING, PAVEMENT MARKERS, PAVEMENT MARKINGS LEGENDS, CURB MARKINGS, LOOP DETECTORS, TRAFFIC SIGNAL EQUIPMENT, ETC.) DAMAGED OR REMOVED AS A RESULT OF OPERATIONS AND NOT DESIGNATED FOR REMOVAL. REPAIRS AND REPLACEMENTS SHALL BE EQUAL TO THE EXISTING IMPROVEMENTS.
- TEMPORARY TRAFFIC SIGNAL DETECTION. THE CONTRACTOR SHALL INSTALL CITY APPROVED TEMPORARY VIDEO OR RADAR DETECTION WHEN EXISTING TRAFFIC SIGNAL DETECTION SYSTEMS ARE DAMAGED, DISABLED, OR BECOME INEFFECTIVE DUE TO CONSTRUCTION FOR A PERIOD OF FIVE (5) OR MORE DAYS. THE CONTRACTOR SHALL COMPLETELY REMOVE ALL TEMPORARY TRAFFIC SIGNAL DETECTION EQUIPMENT AND RESTORE/INSTALL A CITY APPROVED PERMANENT VEHICLE DETECTION SYSTEM UPON COMPLETION OF CONSTRUCTION. ALL INSTALLATIONS AND REMOVALS ARE SUBJECT TO APPROVAL BY THE CITY ENGINEER.
- CHANGES IN WORK. THE CITY RESIDENT ENGINEER WILL OBSERVE THESE TRAFFIC CONTROL PLANS IN OPERATION AND RESERVES THE RIGHT TO MAKE CHANGES AS THE FIELD CONDITIONS WARRANT. ANY SUCH CHANGES SHALL BE DOCUMENTED AND SUPERSEDE THESE PLANS.
- FOR WORK NOT COVERED BY THESE TRAFFIC CONTROL PLANS, THE CONTRACTOR SHALL PREPARE TRAFFIC CONTROL WORKING DRAWINGS AND SUBMIT THEM TO THE CITY RESIDENT ENGINEER. THE CONTRACTOR SHALL ALLOW A MINIMUM OF TWENTY (20) WORKING DAYS FOR REVIEW OF THE WORKING DRAWINGS. UPON APPROVAL OF THE TRAFFIC CONTROL PLAN, THE PUBLIC WORKS TRAFFIC CONTROL SECTION WILL ISSUE A TRAFFIC CONTROL PLAN (TCP) PERMIT FOR THIS WORK.
- THE CONTRACTOR SHALL PLACE "OPEN TRENCH" SIGNS (C27(CA)) ON BARRICADES WITHIN THE WORK ZONE, AHEAD OF ANY WORK AREA WHICH INCLUDES OPEN TRENCHES IN EXCESS OF THREE (3) INCHES IN DEPTH, PER CA MUTCD SECTION 6F.103 (CA) GUIDELINES.
- CONTRACTOR TO OBTAIN CALTRANS PERMIT AND CITY OF IMPERIAL BEACH PERMIT PRIOR TO START OF WORK ON PHASES THAT HAVE SIGNS OR TRAFFIC CONTROL SET UPS THAT ENCR OACH INTO THEIR RESPECTIVE RIGHT-OF-WAY.

**SIGN LEGEND**

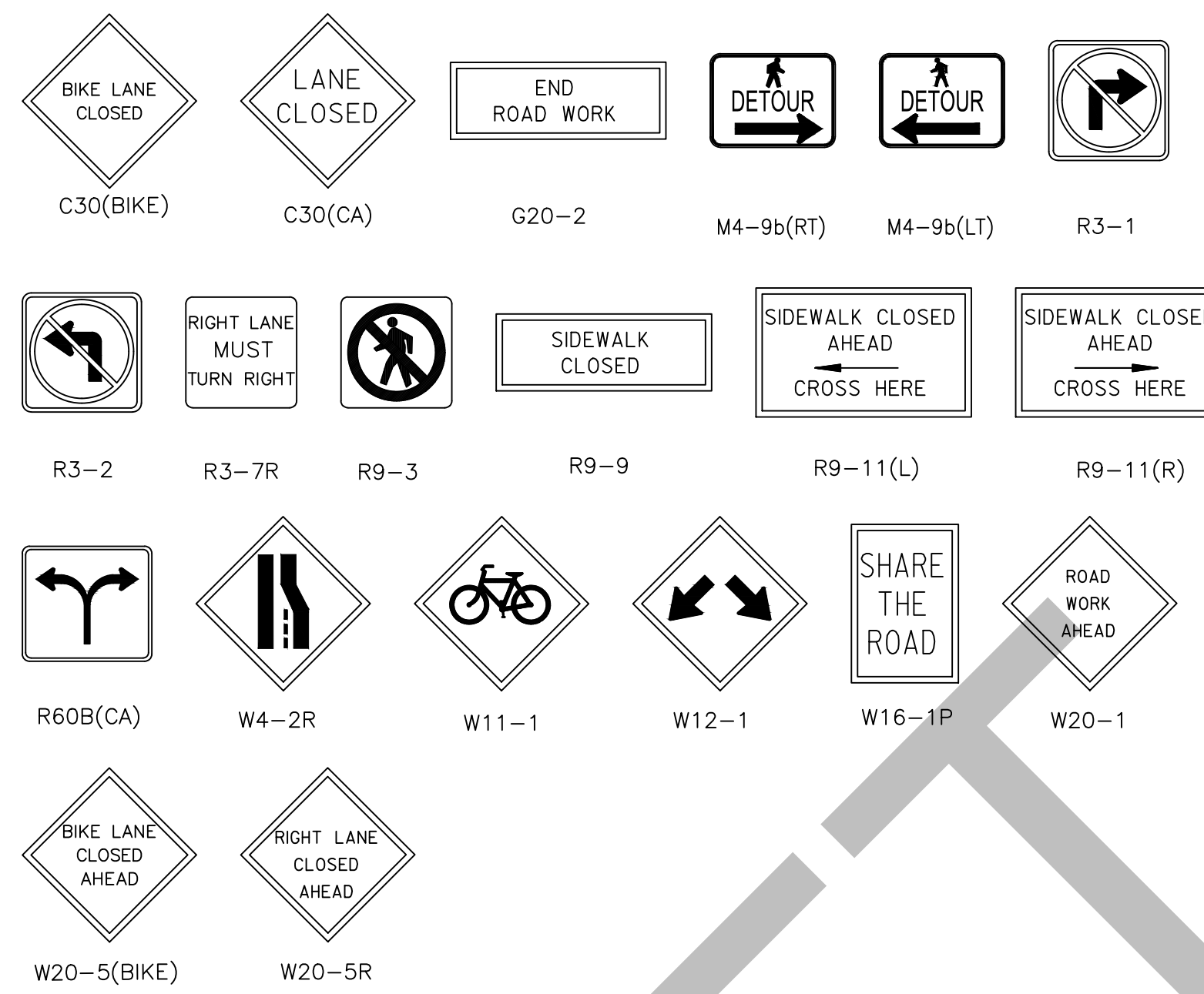

**LEGEND**

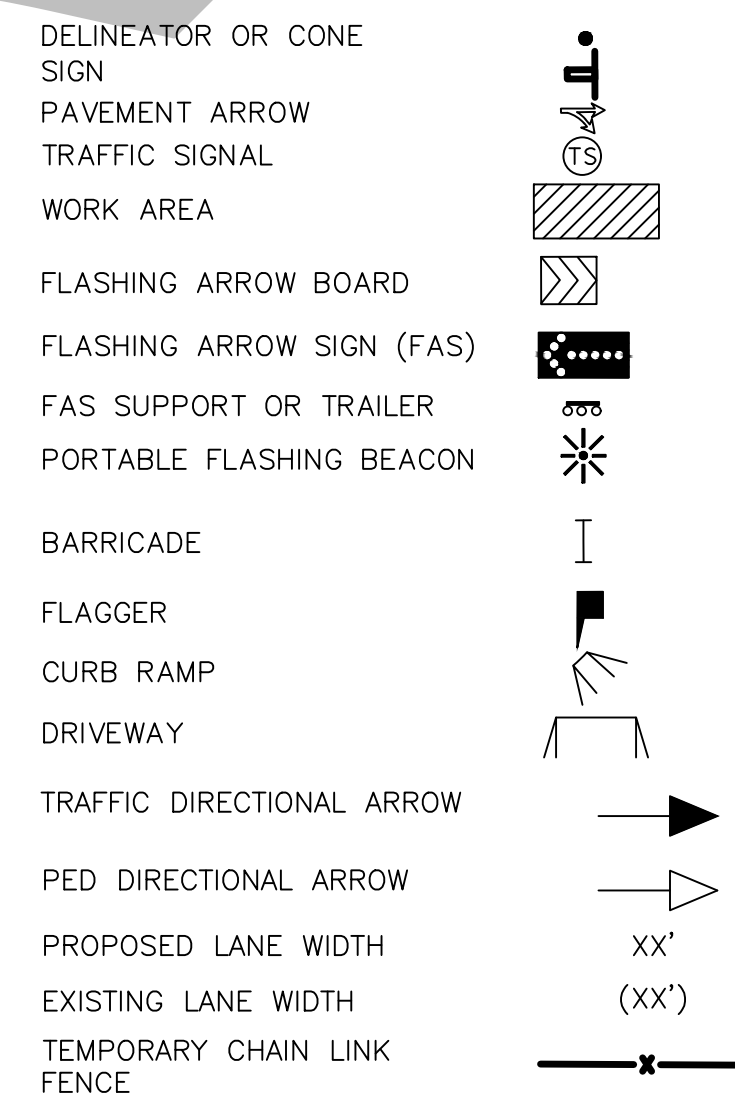

**STREET DATA TABLE**

STREET NAME	CLASSIFICATION	85TH PERCENTILE SPEED (MPH)	ADT (VEHICLES)	R/W (FT)
CORONADO AVENUE (SATURN BLVD - BEYER BLVD)	MAJOR ARTERIAL	35	23,407	VARIES 72 TO 98
IRIS AVENUE (HOWARD AVE - 30TH STREET)	COLLECTOR	30	6,567	81
BEYER BLVD (PALM AVE - CORONADO AVE)	MAJOR ARTERIAL	45	10,526	VARIES 100 TO 115

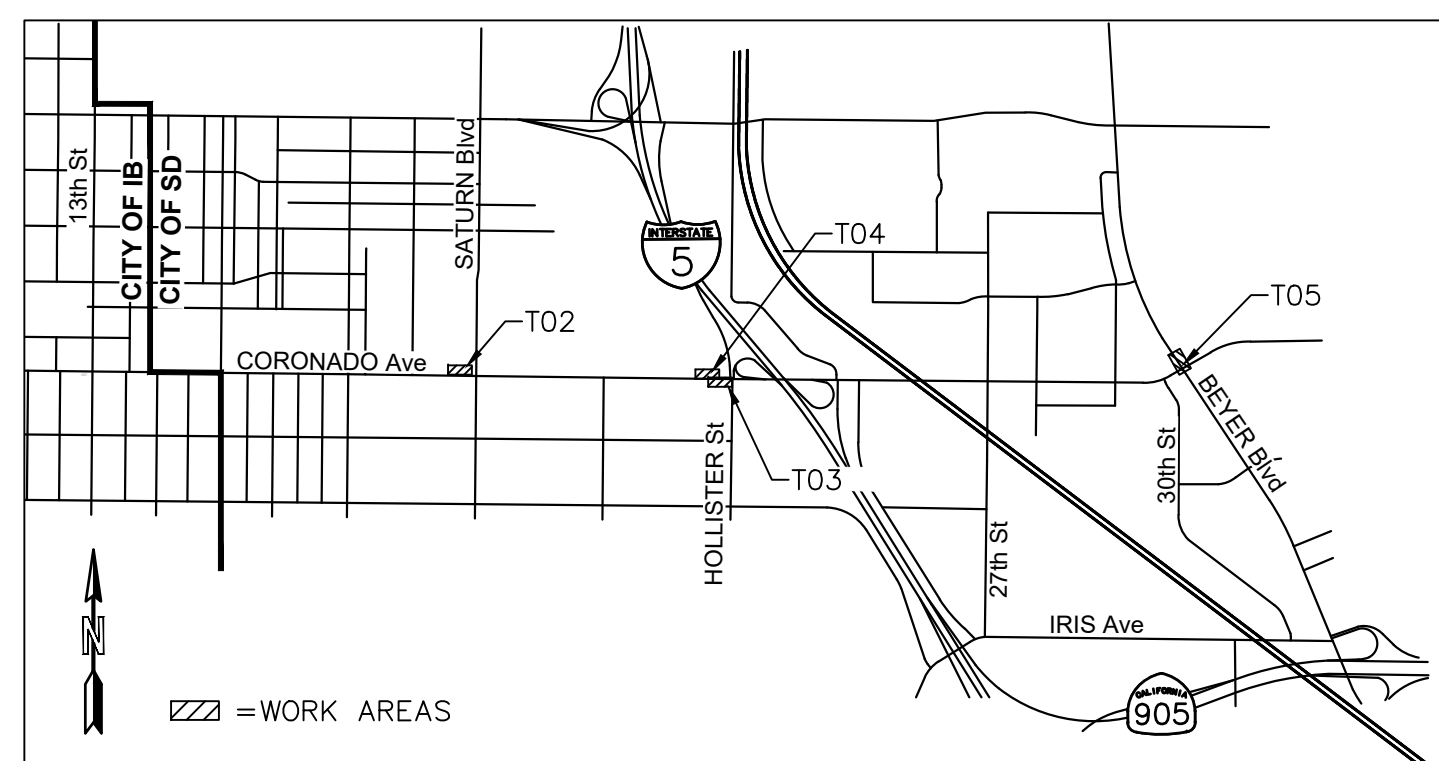

**VICINITY MAP**  
NO SCALE

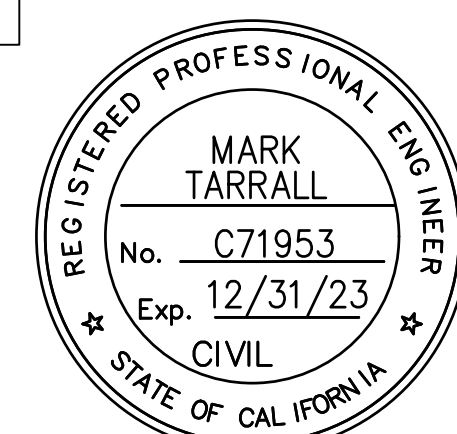

*Mark Tarrall*  
MARK TARRALL R.C.E. NO. 71953 EXP. 12-31-23

DOKKEN ENGINEERING  
1450 FRAZEE ROAD, SUITE 100  
(858) 514-8377

**SHEET INDEX**

DESCRIPTION	SHEET NO.
TRAFFIC CONTROL PLAN TITLE SHEET	T01
CORONADO AVE & SATURN BLVD - WESTBOUND	T02
CORONADO AVE & HOLLISTER AVE - EASTBOUND	T03
CORONADO AVE & HOLLISTER AVE - WESTBOUND	T04
CORONADO AVE & BEYER BLVD	T05

**TABLE 1**

RECOMMENDED SIGN SPACING FOR ADVANCE WARNING SIGN SERIES AND MINIMUM TAPER LENGTH

APPROACH SPEED (S) (MPH)	MINIMUM DISTANCE (FEET) BETWEEN SIGNS AND FROM LAST SIGN TO TAPER	MINIMUM TAPER LENGTHS (L) (FEET) FOR 12-FOOT LANE		
		L	1/2L	1/4L
25	100	125	63	42
30	250	180	90	60
35	250	245	123	82
40	350	320	160	107
45	500	540	270	180
50	500	600	300	200
55+	1000	660	330	220

L FOR MERGE TAPER  
1/2L FOR SHIFT TAPER  
1/4L FOR SHOULDER TAPER

**TABLE 2**

RECOMMENDED TAPER LENGTH AND MAXIMUM CHANNELIZER/CONE SPACING

APPROACH SPEED (S) (MPH)	BUFFER LENGTH (FEET)	MAX CONE SPACING			NOTES:
		TAPER	TANGENT	CONFLICT(*)	
25	125	25	50	12	L = S x W FOR SPEEDS GREATER THAN 40 MPH
30	200	30	60	15	
35	250	35	70	17	L = (W x S^2) / 60 FOR SPEEDS OF 40 MPH OR LESS
40	305	40	80	20	
45	360	45	90	22	WHERE:
50	425	50	100	25	L = MINIMUM LENGTH OF TAPER (FEET)
55+	495	55	100	27	S = APPROACH SPEED (MPH) = POSTED SPEED LIMIT OR OFF-PEAK 85TH % SPEED PRIOR TO WORK STARTING OR ANTICIPATED OPERATING SPEED

(\*) FACING OPPOSING TRAFFIC, ADJACENT TO WORK AREA OR CONFLICTING WITH EXISTING STRIPING

W = WIDTH OF OFFSET (FEET)

PRIVATE CONTRACT

TRAFFIC CONTROL PLAN FOR: <b>IRIS RAPID CORRIDOR AND STATION DESIGN</b> IMPERIAL BEACH BLVD/CORONADO AVE				
CITY OF SAN DIEGO, CALIFORNIA DEVELOPMENT SERVICES DEPARTMENT SHEET 38 OF 42 SHEETS				PROJECT NO. XXXXXX
FOR CITY ENGINEER _____ DATE _____				V.T.M. _____
DESCRIPTION	BY	APPROVED	DATE	FILMED
AS-BUILTS				
CONTRACTOR _____ DATE STARTED _____				
INSPECTOR _____ DATE COMPLETED _____				
				XXXXX-T01-D

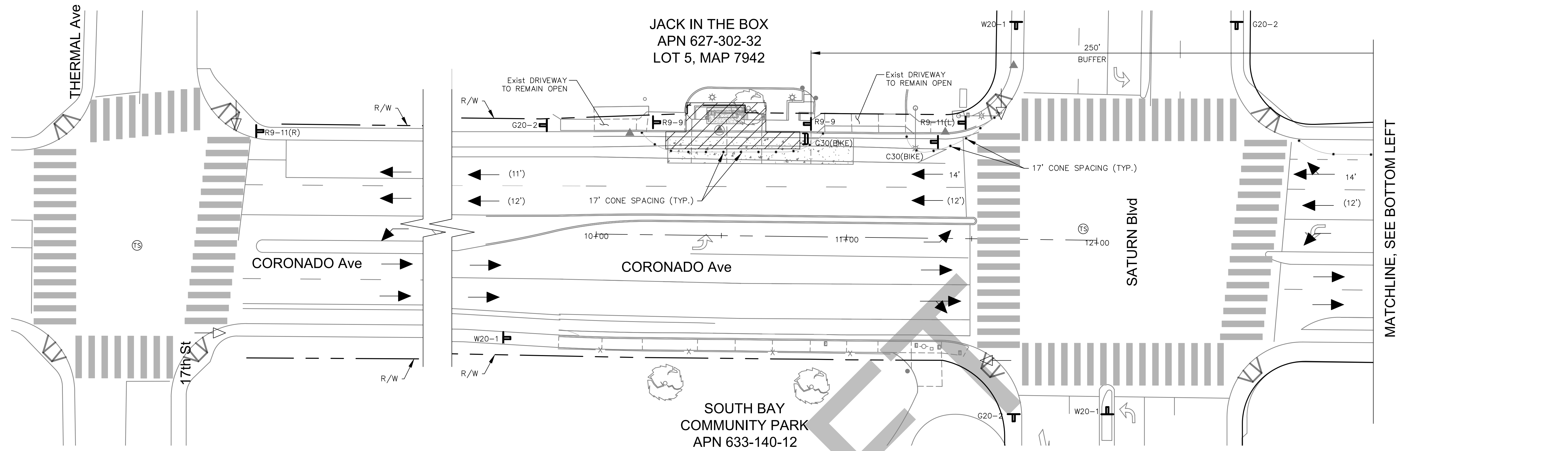

PLAN  
SCALE: 1" = 20'

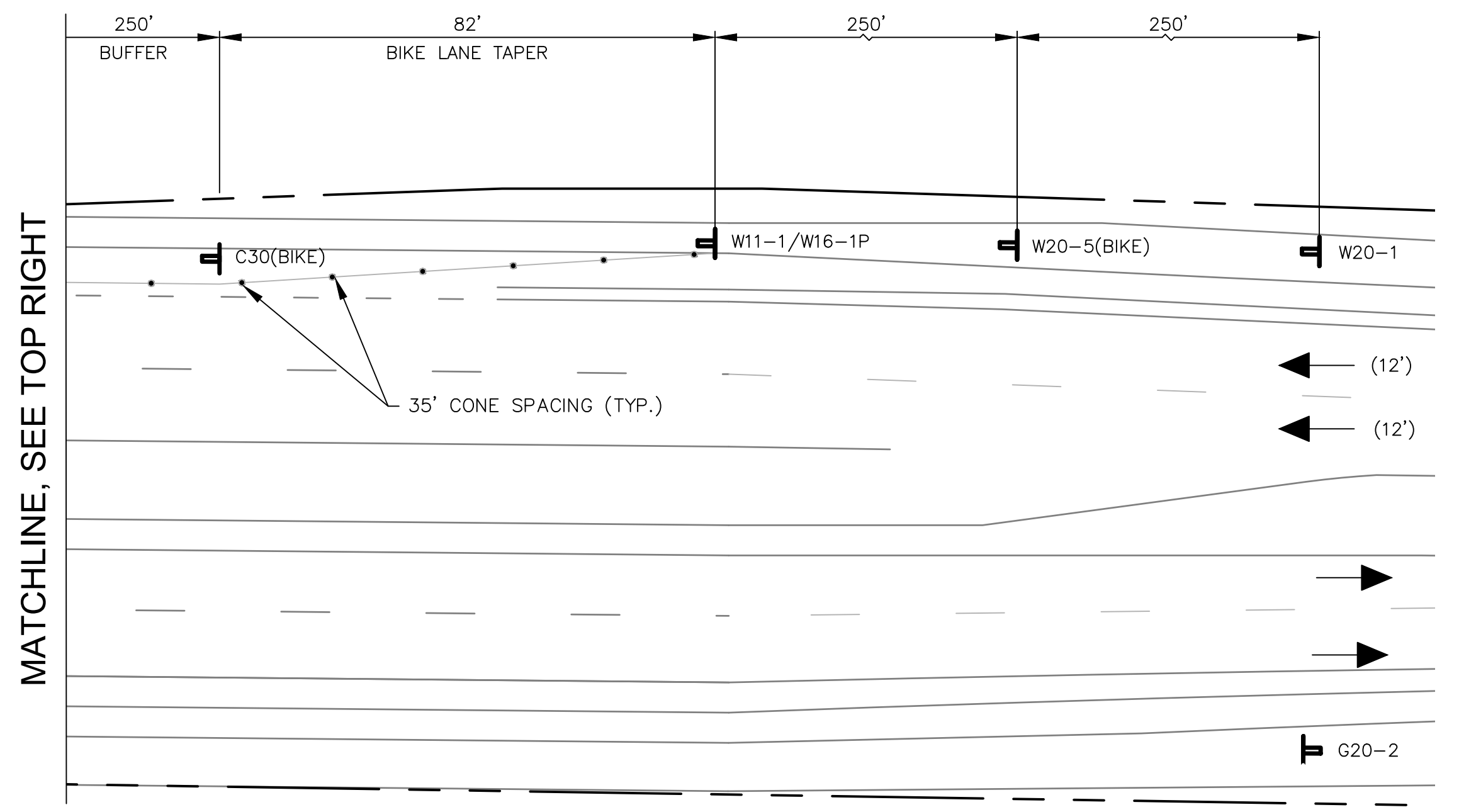

PLAN



SIGN LEGEND

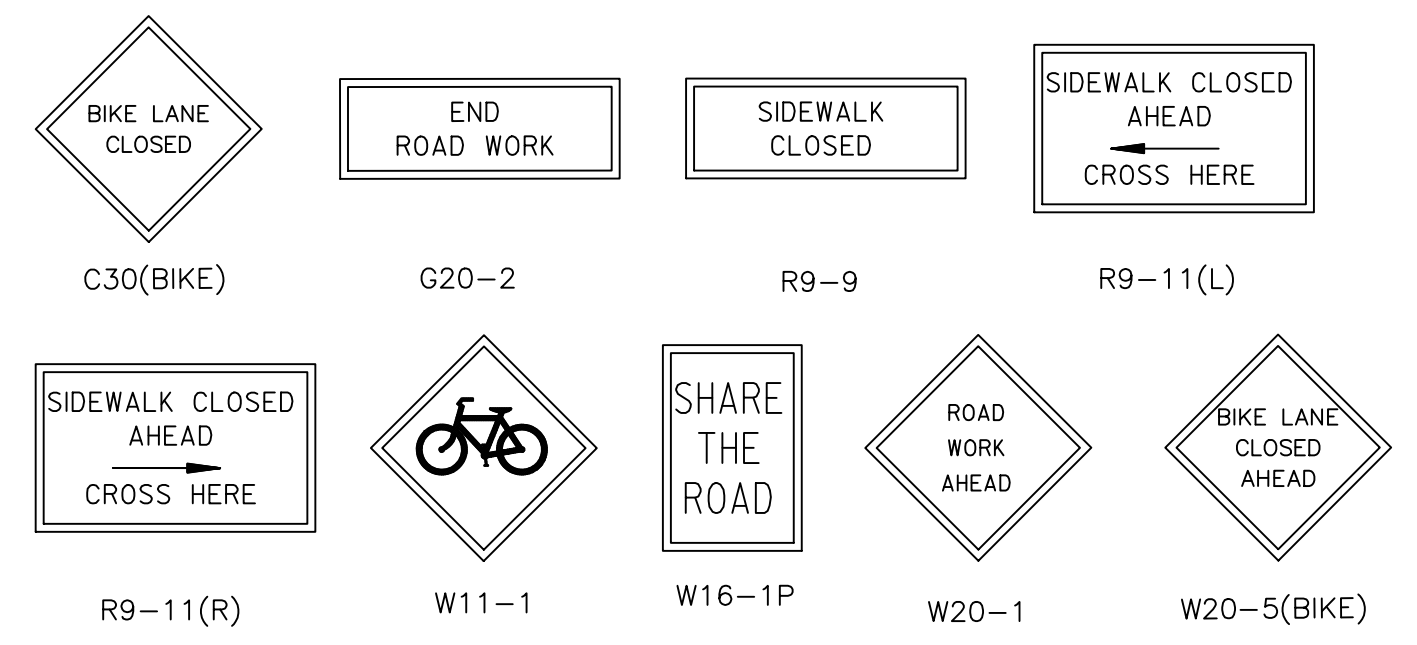

LEGEND

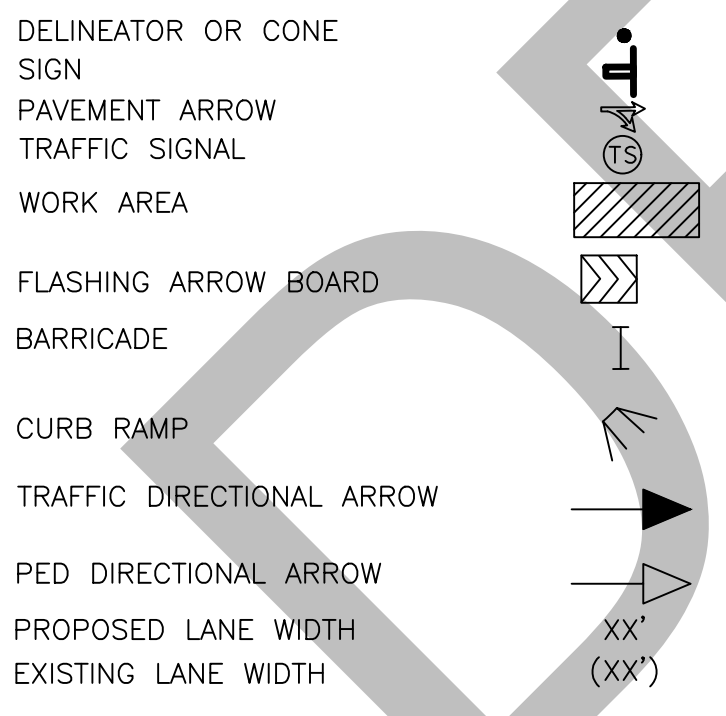

NOTES

- ACCESS TO DRIVEWAYS TO BE MAINTAINED AT ALL TIMES.
- TRAFFIC SIGNAL TO REMAIN OPERATIONAL.
- CONTRACTOR TO COORDINATE WORK WITH PROPERTY OWNER.
- W20-1/G20-2 TO BE PLACED ON ALL AFFECTED CROSS STREETS.
- CONTRACTOR TO MAINTAIN ADA PEDESTRIAN PATH OF TRAVEL ON SIDEWALK DURING NON-WALKING HOURS.

WORK HOURS 9:30 AM TO 2:30 PM  
WORK DAYS MONDAY THROUGH FRIDAY

WORK TO BE DONE

SIDEWALK REPLACEMENT & BUS SHELTER INSTALLATION  
NO ROADWAY IMPROVEMENTS

POSTED SPEED

CORONADO AVENUE = 35 MPH

TRAFFIC CONTROL DESIGN SPEED

CORONADO AVENUE = 35 MPH



*MB Tarrall*  
MARK TARRALL R.C.E. NO. 71953 EXP. 12-31-23

DOKKEN ENGINEERING  
1450 FRAZEE ROAD, SUITE 100  
(858) 514-8377

DATE

PRIVATE CONTRACT			
TRAFFIC CONTROL PLAN FOR: <b>IRIS RAPID CORRIDOR AND STATION DESIGN</b> IMPERIAL BEACH BLVD/CORONADO AVE			
CITY OF SAN DIEGO, CALIFORNIA DEVELOPMENT SERVICES DEPARTMENT SHEET 39 OF 42 SHEETS			PROJECT NO. XXXXXX
FOR CITY ENGINEER	DATE	V.T.M.	
DESCRIPTION	BY	APPROVED	DATE FILMED
AS-BUILTS			
CONTRACTOR	DATE STARTED		
INSPECTOR	DATE COMPLETED		
			1790-6299 NAD83 COORDINATES
			150-1739 LAMBERT COORDINATES
			XXXXX-T02-D

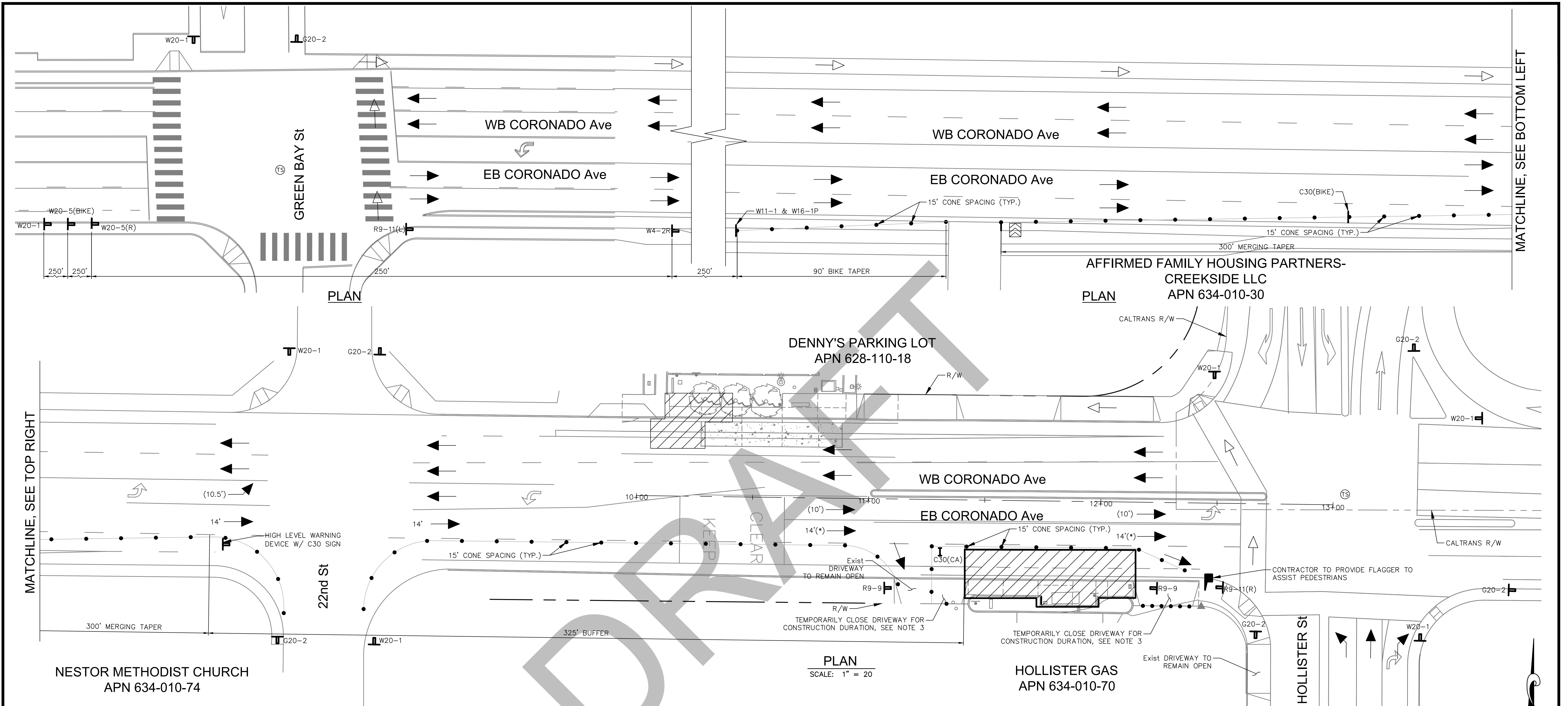

MATCHLINE, SEE TOP RIGHT

MATCHLINE, SEE BOTTOM LEFT

- NOTES**
- ACCESS TO DRIVEWAYS TO BE MAINTAINED AT ALL TIMES UNLESS OTHERWISE NOTED.
  - TRAFFIC SIGNAL TO REMAIN OPERATIONAL.
  - CONTRACTOR TO COORDINATE WORK WITH PROPERTY OWNER.
  - W20-1/G20-2 TO BE PLACED ON ALL AFFECTED CROSS STREETS.
  - CONTRACTOR TO MAINTAIN ADA PEDESTRIAN PATH OF TRAVEL ON SIDEWALK DURING NON-WALKING HOURS.
  - BUS PAD CONSTRUCTION (DEMOLITION, POUR, CURE TO OCCUR FRIDAY THROUGH SUNDAY AS A CONTINUOUS CLOSURE.
  - CONTRACTOR TO OBTAIN CALTRANS PERMITS FOR TRAFFIC CONTROL DEVICES IN CALTRANS RIGHT-OF-WAY, PRIOR TO START OF WORK.
  - (\* ) FOR BUS PAD DEMOLITION, POUR, AND INSTALLATION BEING PERFORMED FRIDAY THROUGH SUNDAY, THIS LANE CAN BE REDUCED DOWN TO 11'.

**WORK TO BE DONE**  
SIDEWALK REPLACEMENT, BUS SHELTER INSTALLATION, & BUS PAD INSTALLATION

**POSTED SPEED**  
CORONADO AVENUE = 35 MPH

**TRAFFIC CONTROL DESIGN SPEED**  
CORONADO AVENUE = 35 MPH

**WORK HOURS** 9:30 AM TO 2:30 PM  
**WORK DAYS** MONDAY THROUGH FRIDAY

**LEGEND**

- DELINEATOR OR CONE SIGN
- PAVEMENT ARROW
- TRAFFIC SIGNAL
- WORK AREA
- FLASHING ARROW BOARD
- BARRICADE
- CURB RAMP
- TRAFFIC DIRECTIONAL ARROW
- PED DIRECTIONAL ARROW
- PROPOSED LANE WIDTH
- EXISTING LANE WIDTH
- FLAGGER

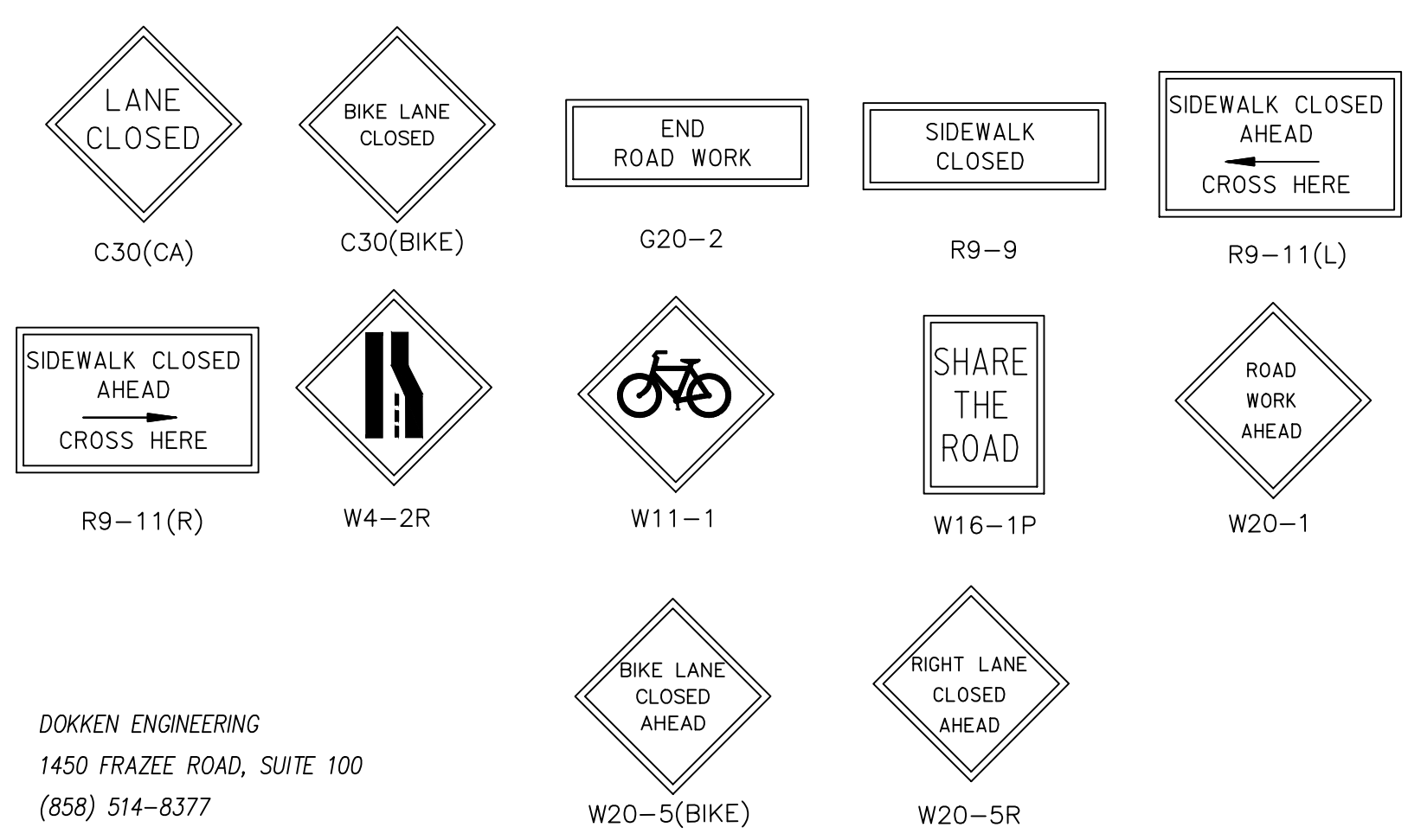

*Mark Tarrall*  
MARK TARRALL R.C.E. NO. 71953 EXP. 12-31-23

DOKKEN ENGINEERING  
1450 FRAZEE ROAD, SUITE 100  
(858) 514-8377

**PLAN**  
SCALE: 1" = 20'

**HOLLISTER GAS**  
APN 634-010-70

PRIVATE CONTRACT

**TRAFFIC CONTROL PLAN FOR IRIS RAPID CORRIDOR AND STATION DESIGN**  
IMPERIAL BEACH BLVD/CORONADO AVE

CITY OF SAN DIEGO, CALIFORNIA DEVELOPMENT SERVICES DEPARTMENT SHEET 40 OF 42 SHEETS		PROJECT NO. XXXXXX
FOR CITY ENGINEER	DATE	V.T.M.
DESCRIPTION	BY	APPROVED
		DATE
		FILMED
AS-BUILTS		
CONTRACTOR	DATE STARTED	
INSPECTOR	DATE COMPLETED	

1790-6299  
NAD83 COORDINATES  
150-1739  
LAMBERT COORDINATES

XXXXX-T03-D



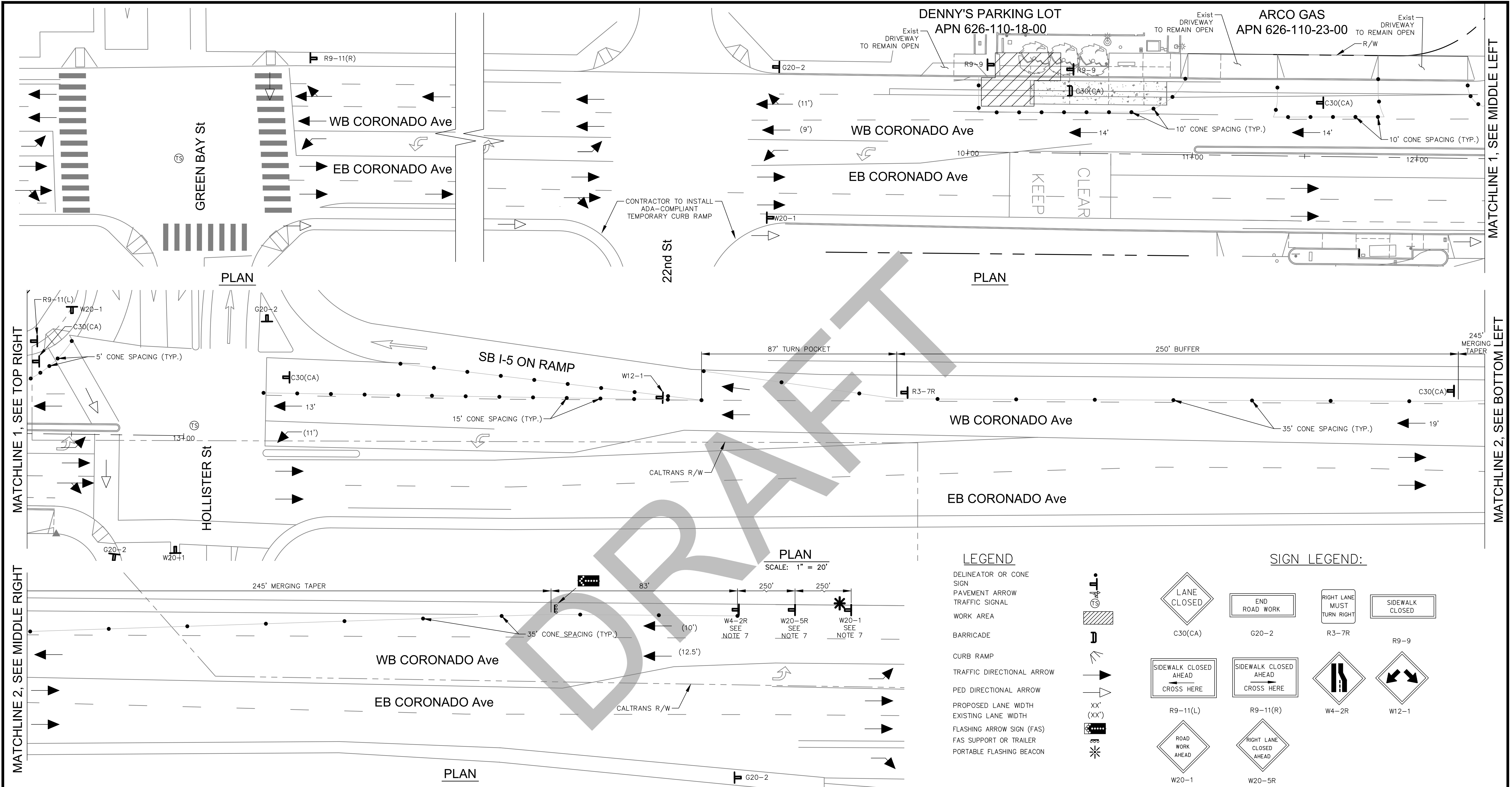

MATCHLINE 1, SEE TOP RIGHT  
MIDDLE RIGHT  
MIDDLE LEFT  
BOTTOM LEFT  
MATCHLINE 2, SEE BOTTOM LEFT

- NOTES**
- ACCESS TO DRIVEWAYS TO BE MAINTAINED AT ALL TIMES.
  - TRAFFIC SIGNAL TO REMAIN OPERATIONAL.
  - CONTRACTOR TO COORDINATE WORK WITH PROPERTY OWNER.
  - W20-1/G20-2 TO BE PLACED ON ALL AFFECTED CROSS STREETS.
  - CONTRACTOR TO MAINTAIN ADA PEDESTRIAN PATH OF TRAVEL ON SIDEWALK DURING NON-WALKING HOURS.
  - BUS PAD CONSTRUCTION (DEMOLITION, POUR, CURE (TO OCCUR FRIDAY THROUGH SUNDAY AS A CONTINUOUS CLOSURE.
  - EACH ADVANCE WARNING SIGN SHALL BE EQUIPPED WITH AT LEAST TWO FLAGS FOR DAYTIME CLOSURE. EACH FLAG SHALL BE AT LEAST 16" X 16" IN SIZE AND SHALL BE ORANGE OR FLUORESCENT RED-ORANGE IN COLOR. FLASHING BEACONS SHALL BE PLACED AT THE LOCATIONS INDICATED FOR LANE CLOSURE DURING HOURS OF DARKNESS.
  - CONTRACTOR TO OBTAIN NECESSARY CALTRANS PERMITS FOR TRAFFIC CONTROL DEVICES IN CALTRANS RIGHT-OF-WAY, PRIOR TO START OF WORK.

**WORK HOURS** 9:30 AM TO 2:30 PM  
**WORK DAYS** MONDAY THROUGH FRIDAY

**WORK TO BE DONE**  
BUS PAD CONSTRUCTION, SIDEWALK REPLACEMENT & BUS SHELTER INSTALLATION

**POSTED SPEED**  
CORONADO AVENUE = 35 MPH

**TRAFFIC CONTROL DESIGN SPEED**  
CORONADO AVENUE = 35 MPH



*Mark Tarrall*  
MARK TARRALL R.C.E. NO. 71953 EXP. 12-31-23

DOKKEN ENGINEERING  
1450 FRAZEE ROAD, SUITE 100  
(858) 514-8377

**LEGEND**

- DELINEATOR OR CONE SIGN
- PAVEMENT ARROW
- TRAFFIC SIGNAL
- WORK AREA
- BARRICADE
- CURB RAMP
- TRAFFIC DIRECTIONAL ARROW
- PED DIRECTIONAL ARROW
- PROPOSED LANE WIDTH
- EXISTING LANE WIDTH
- FLASHING ARROW SIGN (FAS)
- FAS SUPPORT OR TRAILER
- PORTABLE FLASHING BEACON

**SIGN LEGEND:**

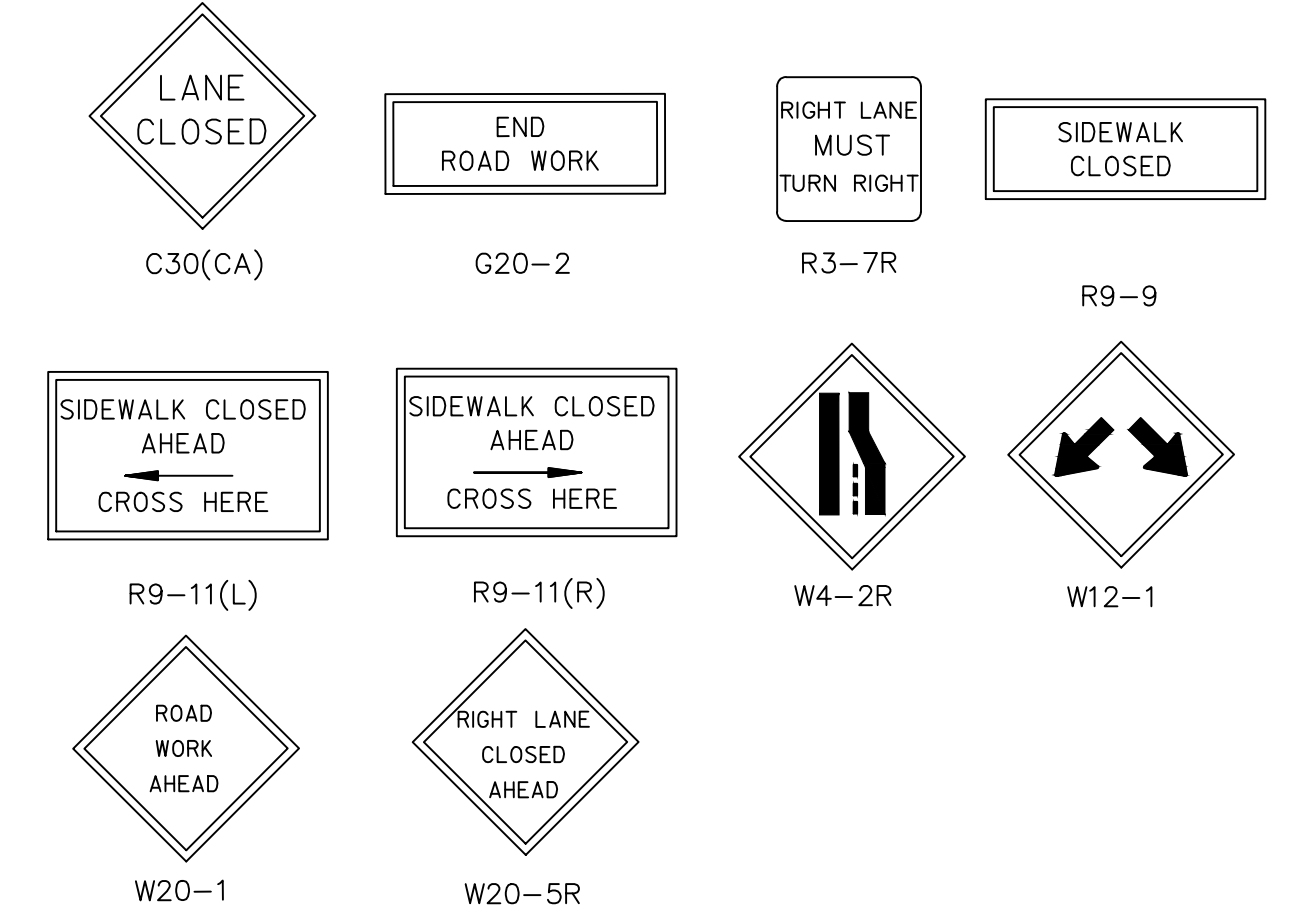

PRIVATE CONTRACT

**TRAFFIC CONTROL PLAN FOR:  
IRIS RAPID CORRIDOR  
AND STATION DESIGN  
IMPERIAL BEACH BLVD/CORONADO AVE**

CITY OF SAN DIEGO, CALIFORNIA DEVELOPMENT SERVICES DEPARTMENT SHEET 41 OF 42 SHEETS		PROJECT NO. XXXXXX
FOR CITY ENGINEER	DATE	V.T.M.
DESCRIPTION	BY	APPROVED
AS-BUILTS	DATE STARTED	DATE COMPLETED
CONTRACTOR	DATE STARTED	DATE COMPLETED
INSPECTOR	DATE STARTED	DATE COMPLETED

1790-6299  
NAD83 COORDINATES  
150-1739  
LAMBERT COORDINATES  
XXXXX-T04-D

**LEGEND**

- DELINEATOR OR CONE SIGN
- PAVEMENT ARROW
- TRAFFIC SIGNAL
- WORK AREA
- CURB RAMP
- TRAFFIC DIRECTIONAL ARROW
- PED DIRECTIONAL ARROW
- PROPOSED LANE WIDTH
- EXISTING LANE WIDTH

**SIGN LEGEND**

- LANE CLOSED  
C30(CA)
- BIKE LANE CLOSED  
C30(BIKE)
- END ROAD WORK  
G20-2
- SIDEWALK CLOSED  
R9-9
- SIDEWALK CLOSED AHEAD  
CROSS HERE  
R9-11(L)
- R9-3
- W11-1
- SHARE THE ROAD  
W16-1P
- ROAD WORK AHEAD  
W20-1
- BIKE LANE CLOSED AHEAD  
W20-5(BIKE)

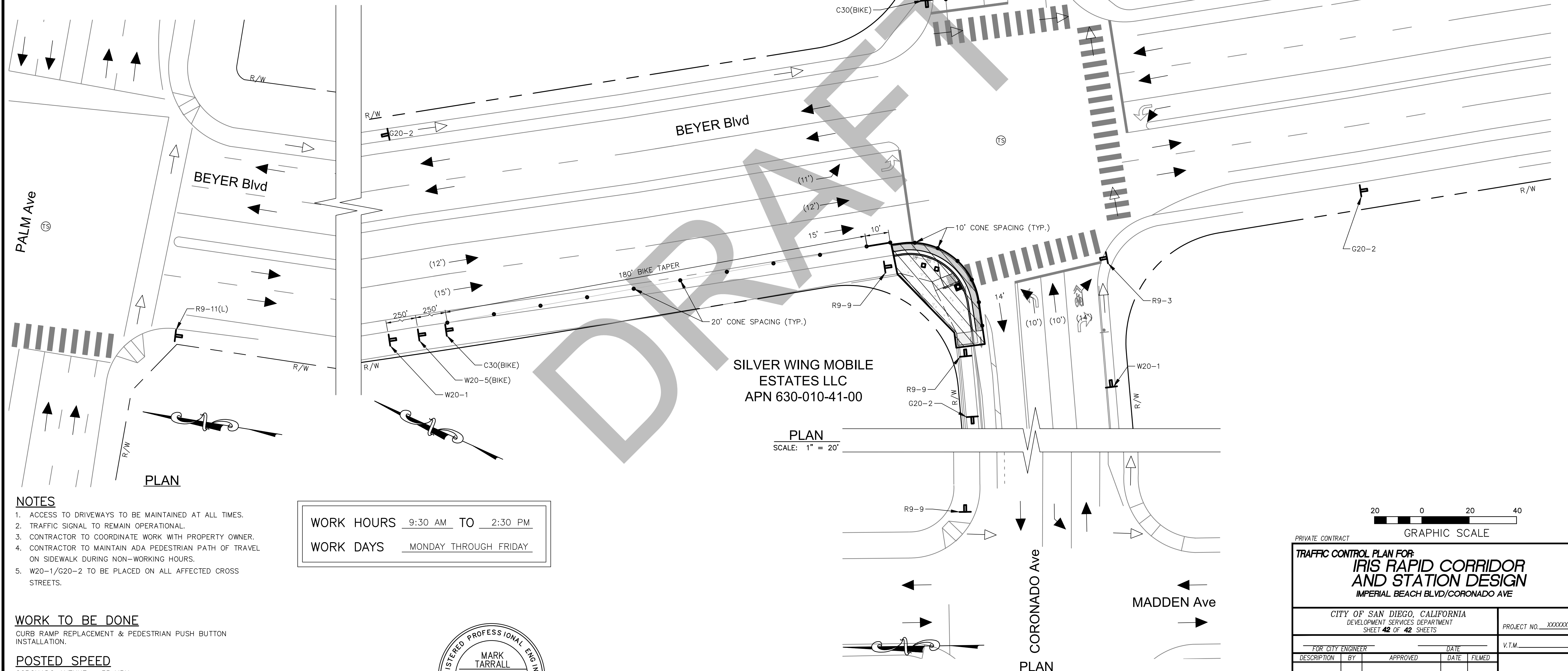

SILVER WING MOBILE ESTATES LLC  
APN 630-010-41-00

PLAN  
SCALE: 1" = 20'

- NOTES**
1. ACCESS TO DRIVEWAYS TO BE MAINTAINED AT ALL TIMES.
  2. TRAFFIC SIGNAL TO REMAIN OPERATIONAL.
  3. CONTRACTOR TO COORDINATE WORK WITH PROPERTY OWNER.
  4. CONTRACTOR TO MAINTAIN ADA PEDESTRIAN PATH OF TRAVEL ON SIDEWALK DURING NON-WORKING HOURS.
  5. W20-1/G20-2 TO BE PLACED ON ALL AFFECTED CROSS STREETS.

WORK HOURS 9:30 AM TO 2:30 PM  
WORK DAYS MONDAY THROUGH FRIDAY

- WORK TO BE DONE**  
CURB RAMP REPLACEMENT & PEDESTRIAN PUSH BUTTON INSTALLATION.
- POSTED SPEED**  
CORONADO AVENUE = 35 MPH  
BEYER BOULEVARD = 45 MPH
- TRAFFIC CONTROL DESIGN SPEED**  
CORONADO AVENUE = 35 MPH  
BEYER BOULEVARD = 45 MPH



*Mark Tarrall*  
MARK TARRALL R.C.E. NO. 71953 EXP. 12-31-23

DOKKEN ENGINEERING  
1450 FRAZEE ROAD, SUITE 100  
(858) 514-8377



PRIVATE CONTRACT

**TRAFFIC CONTROL PLAN FOR:  
IRIS RAPID CORRIDOR  
AND STATION DESIGN  
IMPERIAL BEACH BLVD/CORONADO AVE**

CITY OF SAN DIEGO, CALIFORNIA DEVELOPMENT SERVICES DEPARTMENT SHEET 42 OF 42 SHEETS				PROJECT NO. XXXXXX
FOR CITY ENGINEER	DATE	V.T.M.		
DESCRIPTION	BY	APPROVED	DATE	FILMED
AS-BUILTS				
CONTRACTOR	DATE STARTED	1790-6299 NAD83 COORDINATES		
INSPECTOR	DATE COMPLETED	150-1739 LAMBERT COORDINATES		
				XXXXX-T05-D

**LEGEND:**

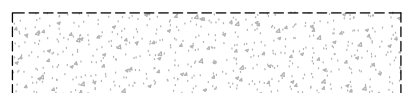
- AC BUS PAD  
(SEE DETAIL A, THIS SHEET) 
- BUS SHELTER THIN SLAB  
FOUNDATION FOOTPRINT 

**NOTES:**

1. SEE SHEET 3 FOR TYPICAL BUS SHELTER DIMENSIONS AND MINIMUM CLEARANCES (UNLESS OTHERWISE NOTED).
2. ALL ROADWAY STRIPING AFFECTED BY BUS PAD INSTALLATION SHALL BE REPLACED IN KIND.
3. COORDINATE EXISTING STREET FURNITURE REMOVAL (BY OTHERS) WITH MTS.

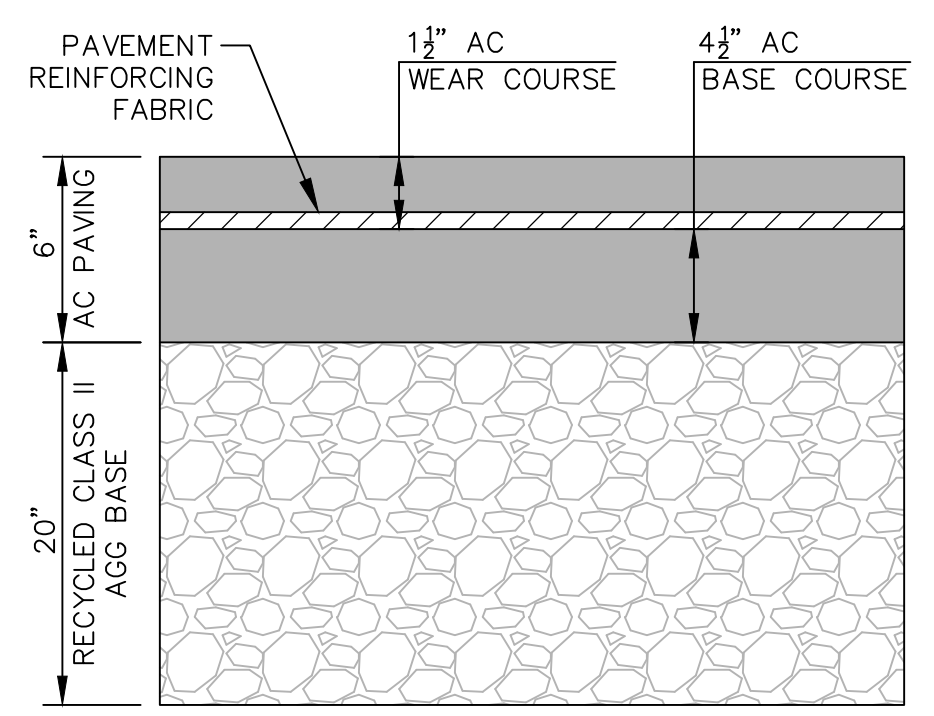
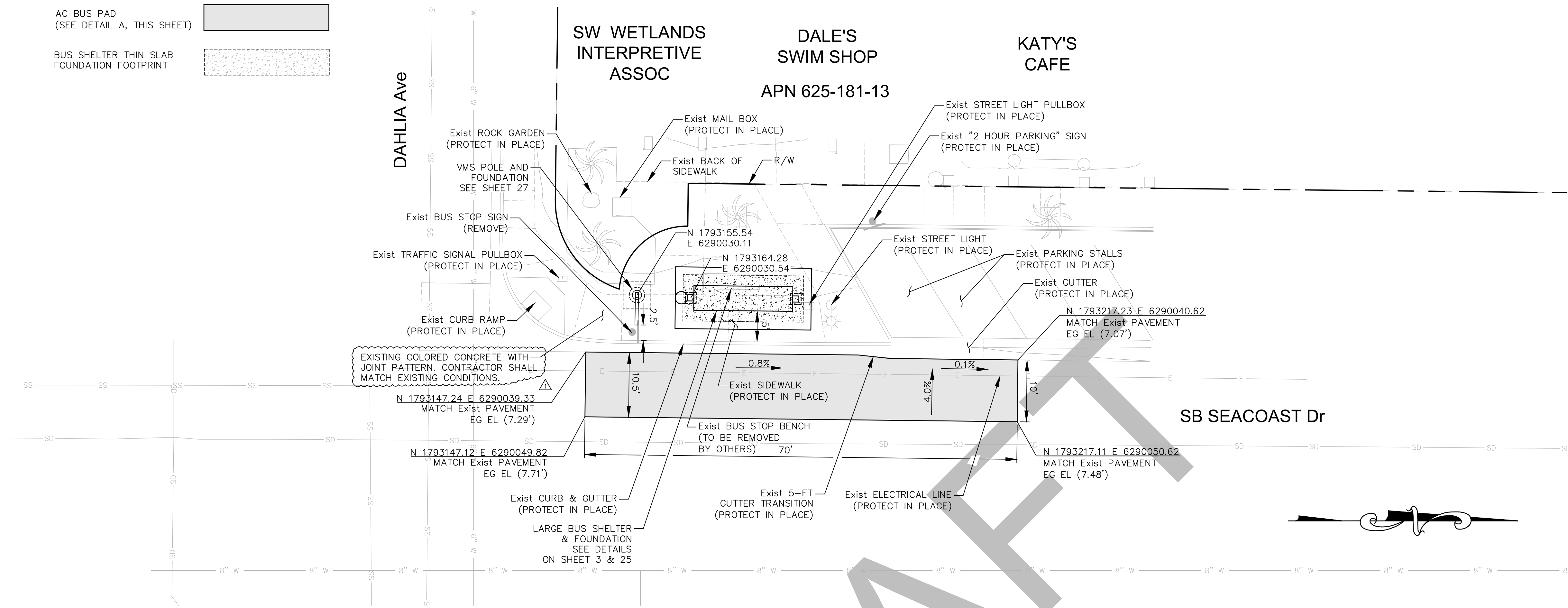

**DETAIL A**  
NOT TO SCALE

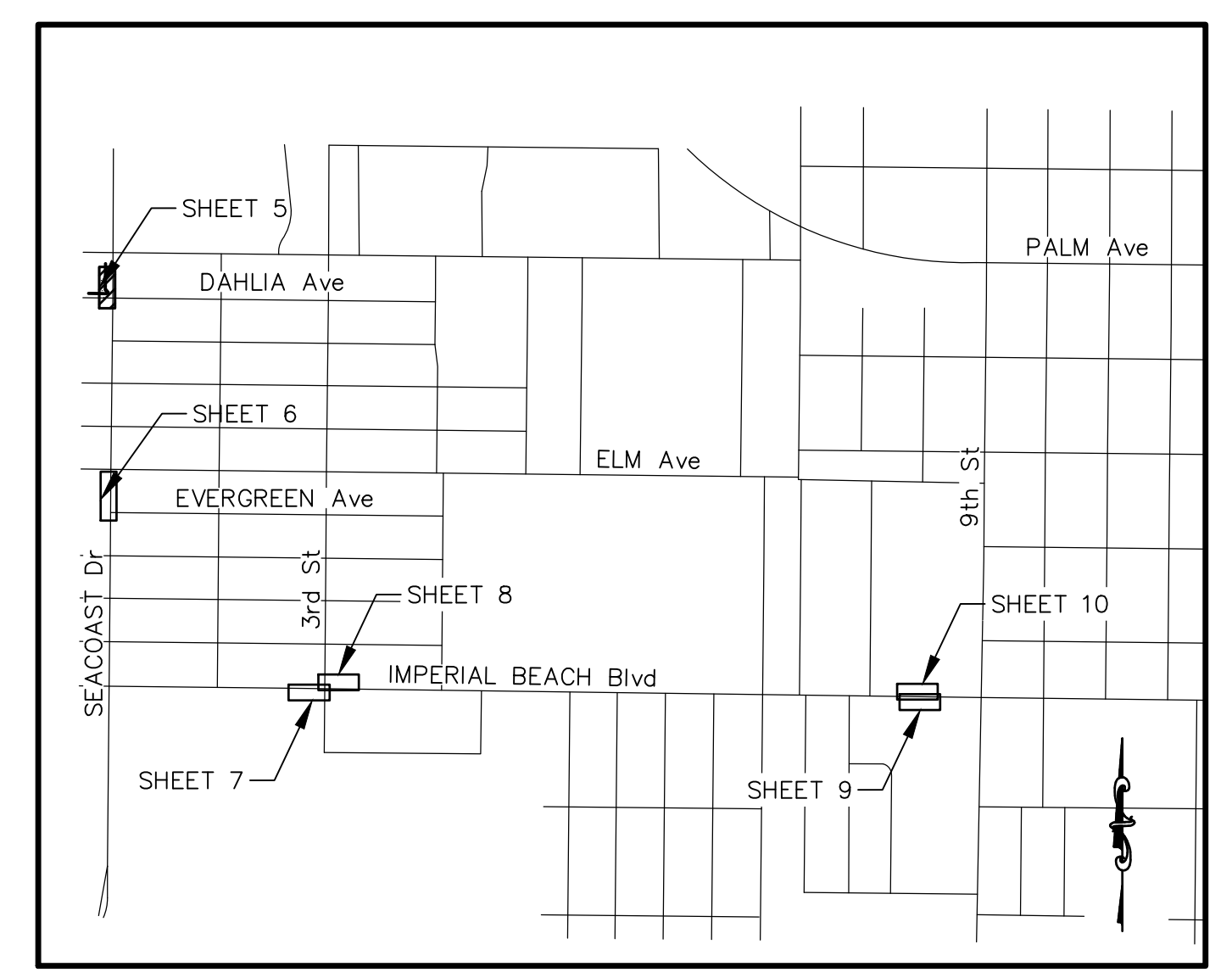
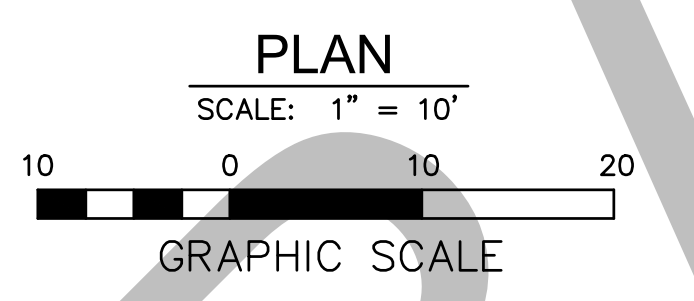

**KEYMAP**  
NOT TO SCALE

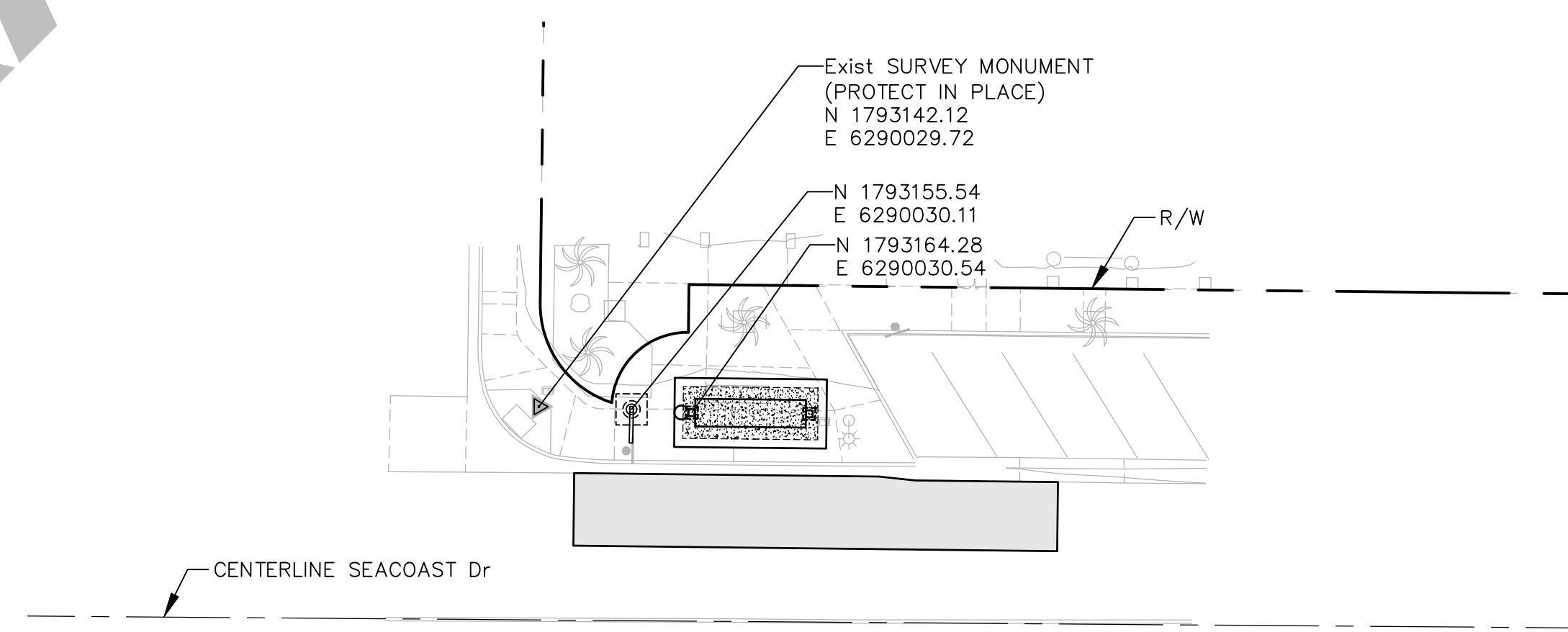

**SURVEY CONTROL POINT LOCATION**  
SCALE: 1" = 20'



*Mark Tarrall*  
MARK TARRALL R.C.E. NO. 71953 EXP. 12-31-23

DOKKEN ENGINEERING  
1450 FRAZEE ROAD, SUITE 100  
(858) 514-8377

**NOTE:**  
THE CITY OF SAN DIEGO ENGINEER DOES NOT CONSTITUTE APPROVAL OF THIS SHEET AS IT ONLY REFLECTS IMPROVEMENTS LOCATED WITHIN CITY OF IMPERIAL BEACH JURISDICTION.

PRIVATE CONTRACT			
<b>IMPROVEMENT PLANS FOR:</b> <b>IRIS RAPID CORRIDOR AND STATION DESIGN</b> IMPERIAL BEACH BLVD/CORONADO AVE			
CITY OF IMPERIAL BEACH, CALIFORNIA		PROJECT NO. 686500	
SHEET 5 OF 89 SHEETS		V.T.M.	
DESCRIPTION	BY	APPROVED	DATE FILMED
CONFORMED	DE		6/20/22
AS-BUILTS			
CONTRACTOR	DATE STARTED		
INSPECTOR	DATE COMPLETED		
			1786-6299 NAD83 COORDINATES
			146-1739 LAMBERT COORDINATES
			<b>05-D</b>

**LEGEND:**

AC BUS PAD  
(SEE DETAIL A, THIS SHEET)

BUS SHELTER THIN SLAB  
FOUNDATION FOOTPRINT

EXISTING COLORED CONCRETE WITH  
JOINT PATTERN. CONTRACTOR SHALL  
MATCH EXISTING CONDITIONS.

**NOTES:**

- SEE SHEET 3 FOR TYPICAL BUS SHELTER DIMENSIONS AND MINIMUM CLEARANCES (UNLESS OTHERWISE NOTED).
- ALL ROADWAY STRIPING AFFECTED BY BUS PAD INSTALLATION SHALL BE REPLACED IN KIND.
- COORDINATE EXISTING LOCAL BUS SHELTER REMOVAL (BY OTHERS) WITH MTS.

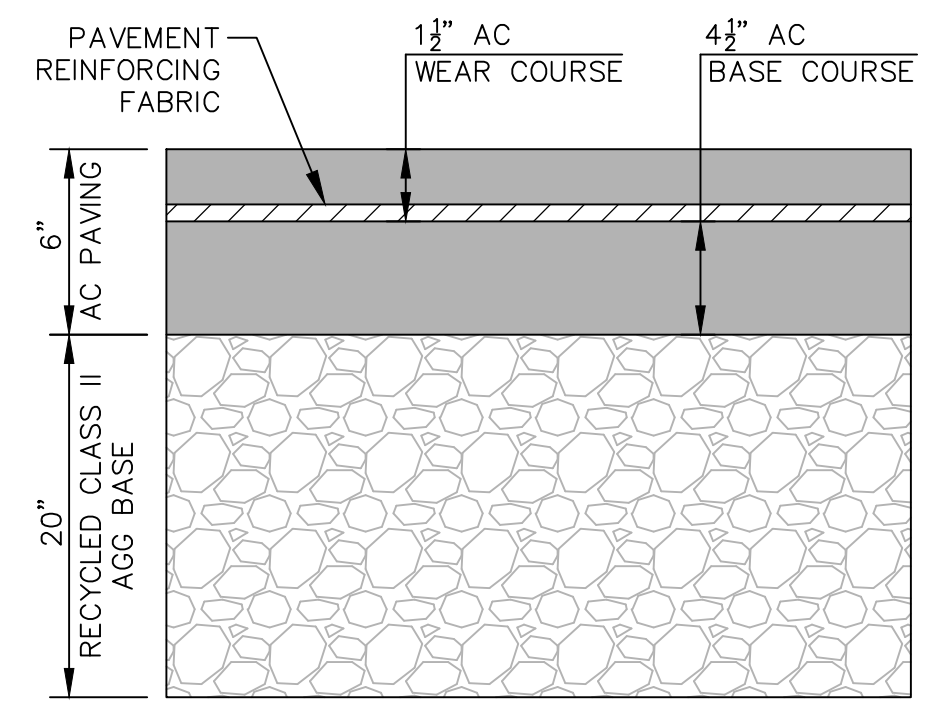
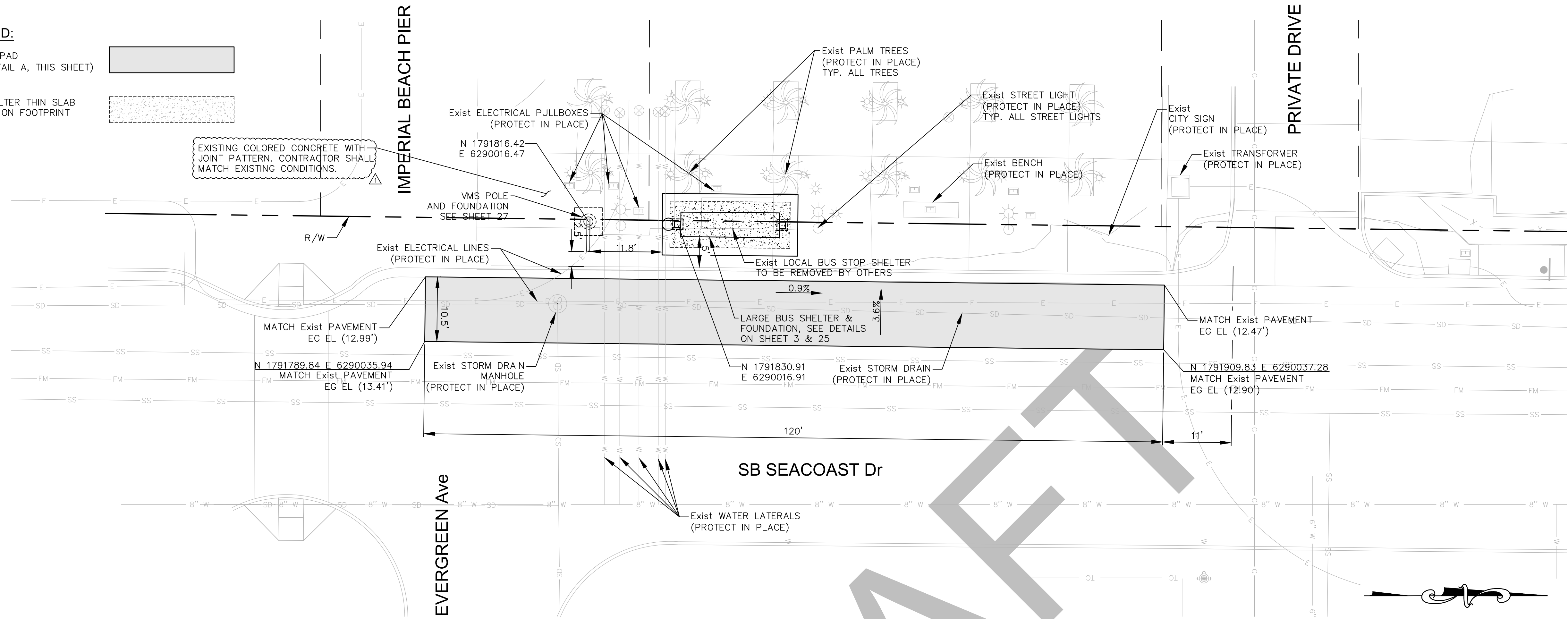

**DETAIL A**  
NOT TO SCALE

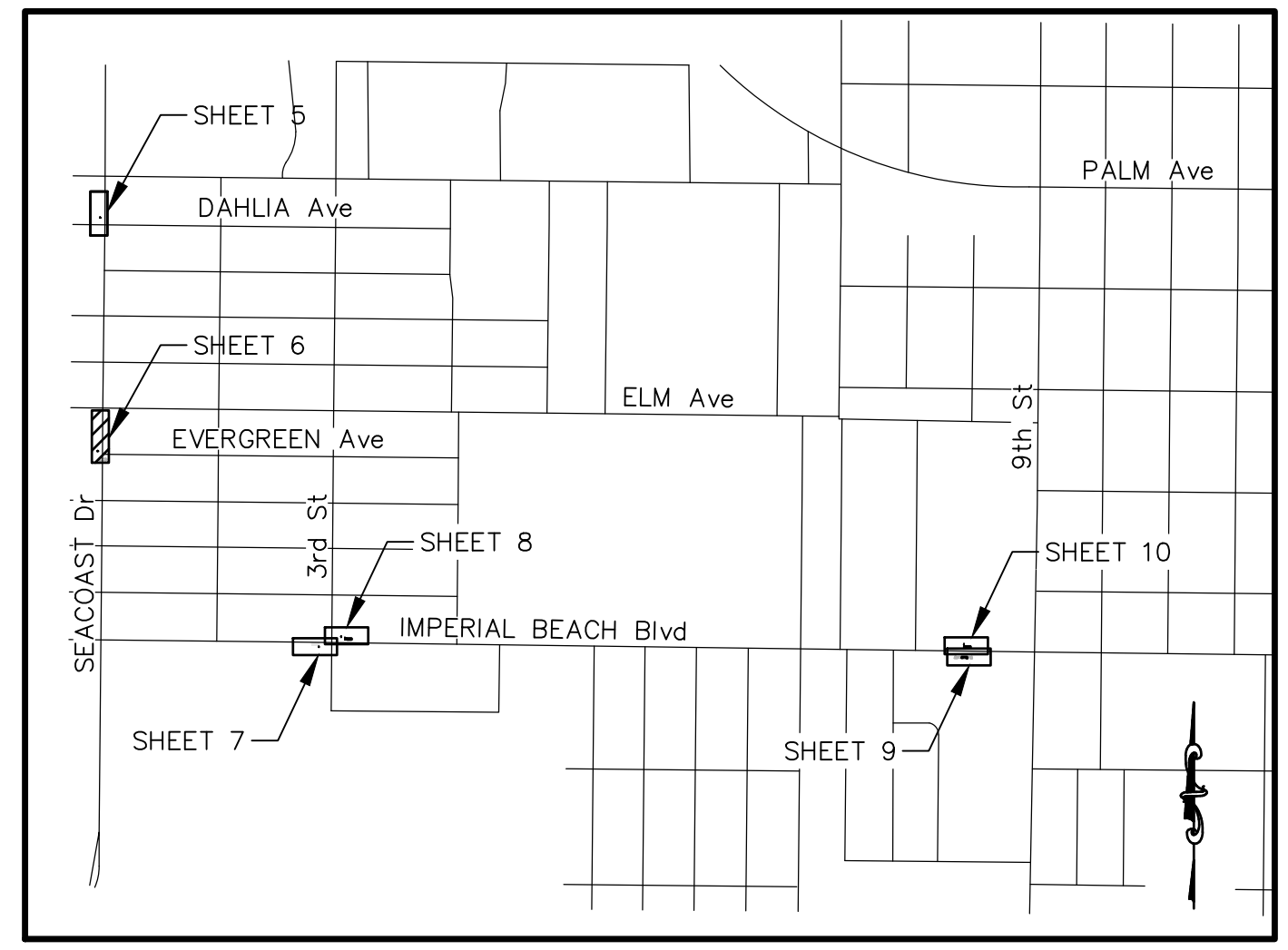
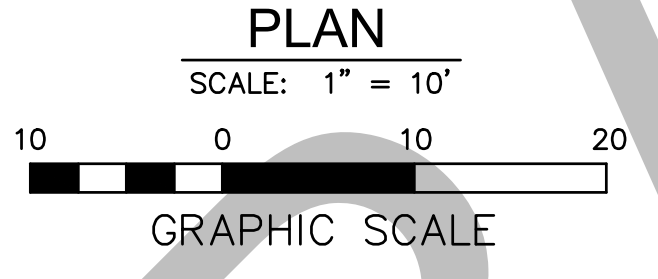

**KEYMAP**  
NOT TO SCALE

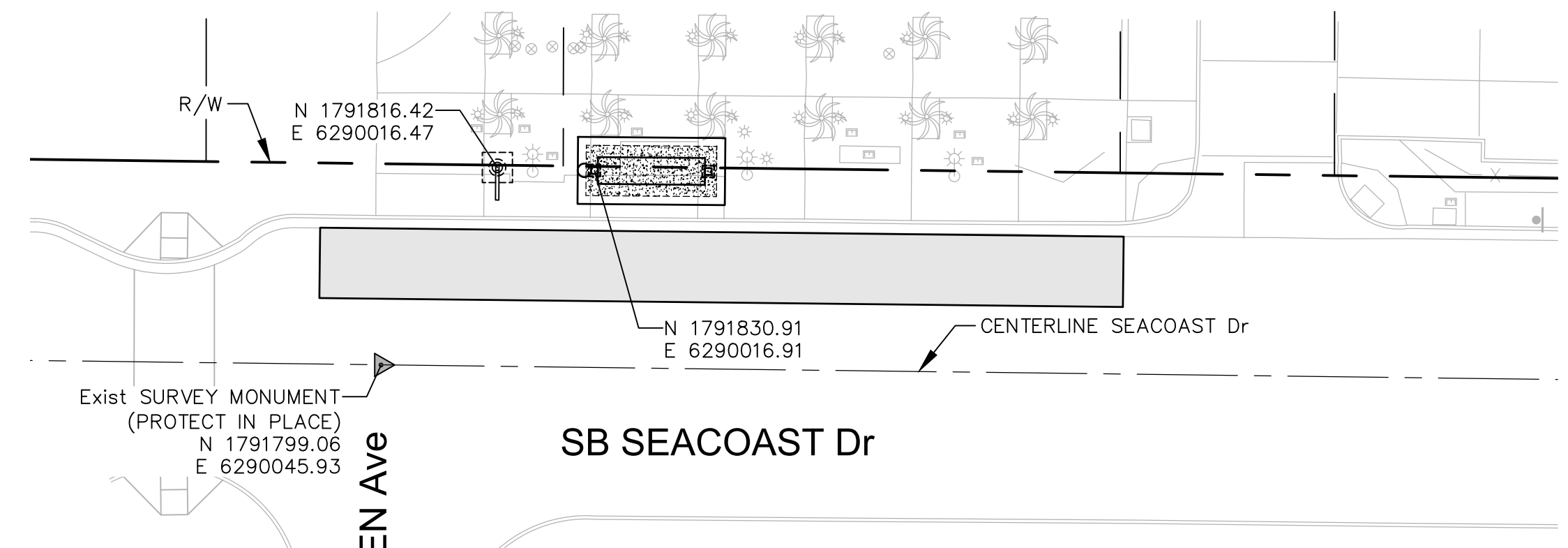

**SURVEY CONTROL POINT LOCATION**  
SCALE: 1" = 20'



*Mark Tarrall*  
MARK TARRALL R.C.E. NO. 71953 EXP. 12-31-23

DOKKEN ENGINEERING  
1450 FRAZEE ROAD, SUITE 100  
(858) 514-8377

**NOTE:**  
THE CITY OF SAN DIEGO ENGINEER DOES NOT CONSTITUTE APPROVAL OF THIS SHEET AS IT ONLY REFLECTS IMPROVEMENTS LOCATED WITHIN CITY OF IMPERIAL BEACH JURISDICTION.

PRIVATE CONTRACT

**IMPROVEMENT PLANS FOR IRIS RAPID CORRIDOR AND STATION DESIGN**  
IMPERIAL BEACH BLVD/CORONADO AVE

CITY OF IMPERIAL BEACH, CALIFORNIA		PROJECT NO. 686500
SHEET 6 OF 69 SHEETS		V.T.M.
DESCRIPTION	BY	APPROVED
CONFORMED	DE	6/20/22
AS-BUILTS		
CONTRACTOR	DATE STARTED	
INSPECTOR	DATE COMPLETED	

1786-6299  
NAD83 COORDINATES  
146-1739  
LAMBERT COORDINATES

**06-D**

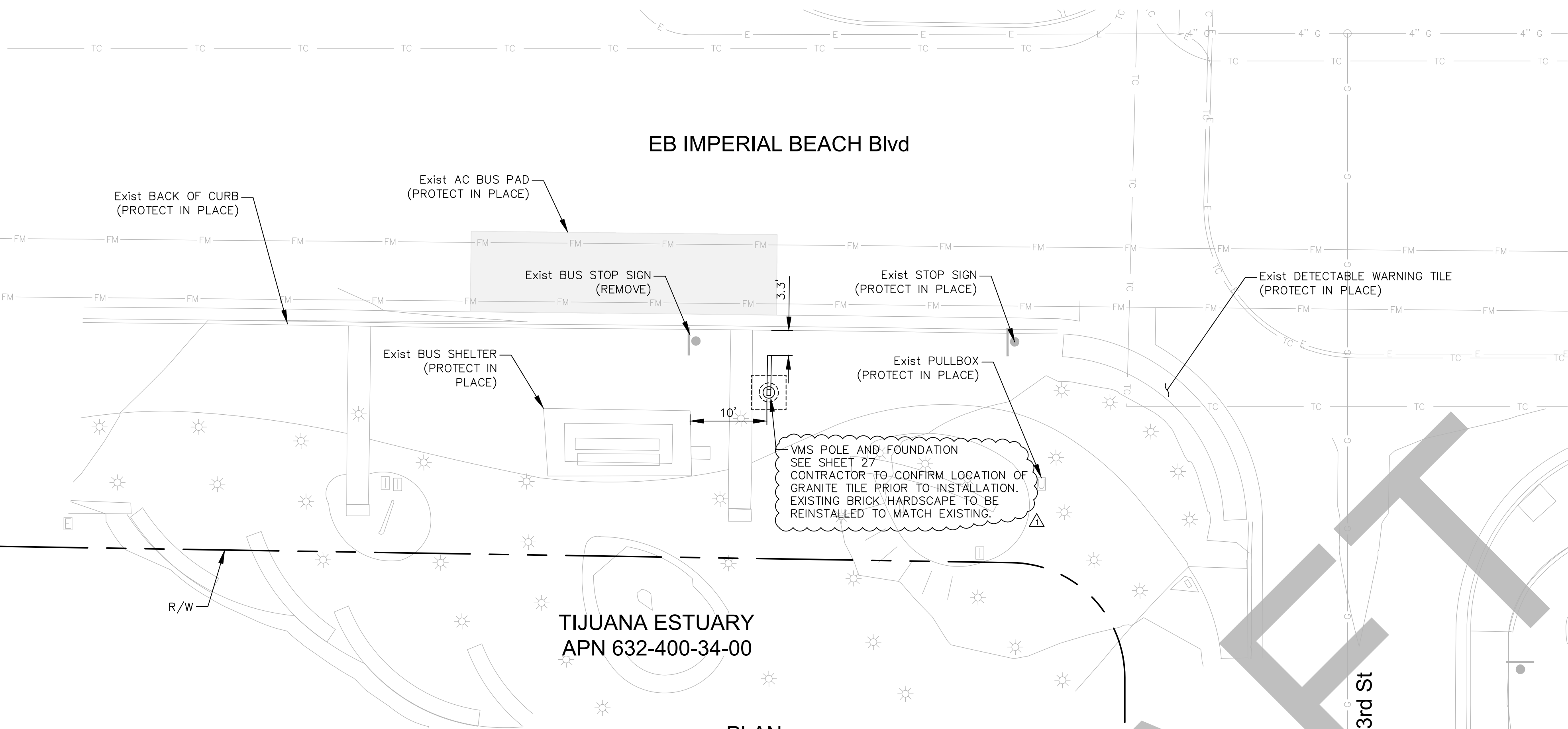

**LEGEND:**  
 Exist AC BUS PAD  
 (6" HMA OVER 20" AB)

TIJUANA ESTUARY  
 APN 632-400-34-00

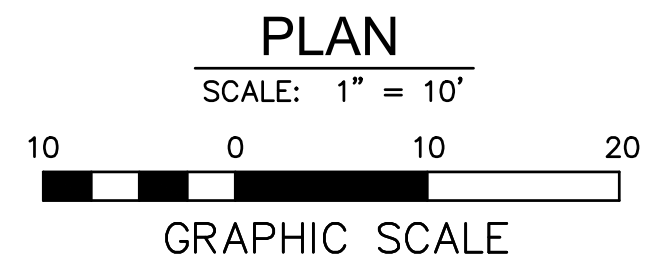

DRAFT

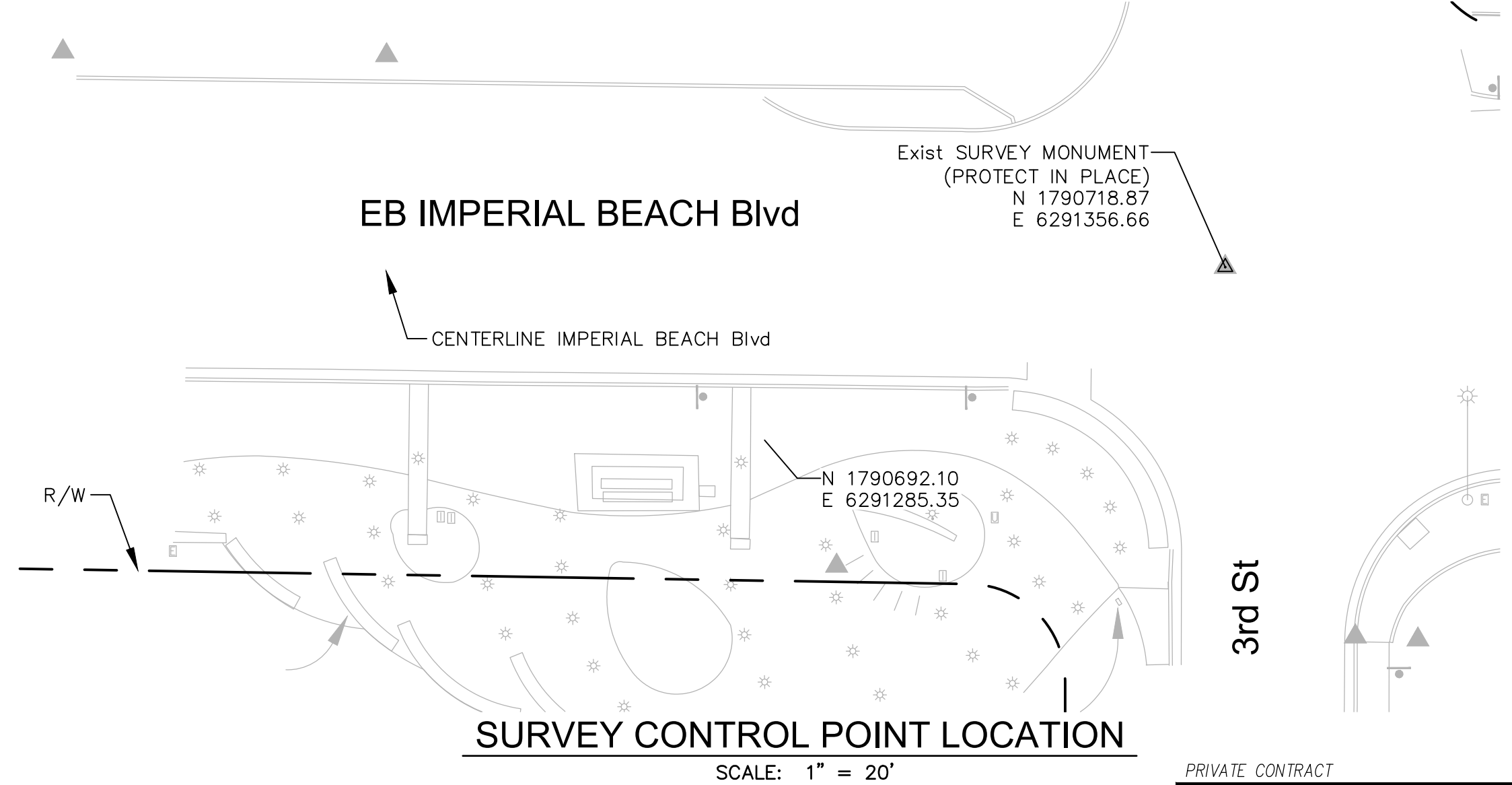
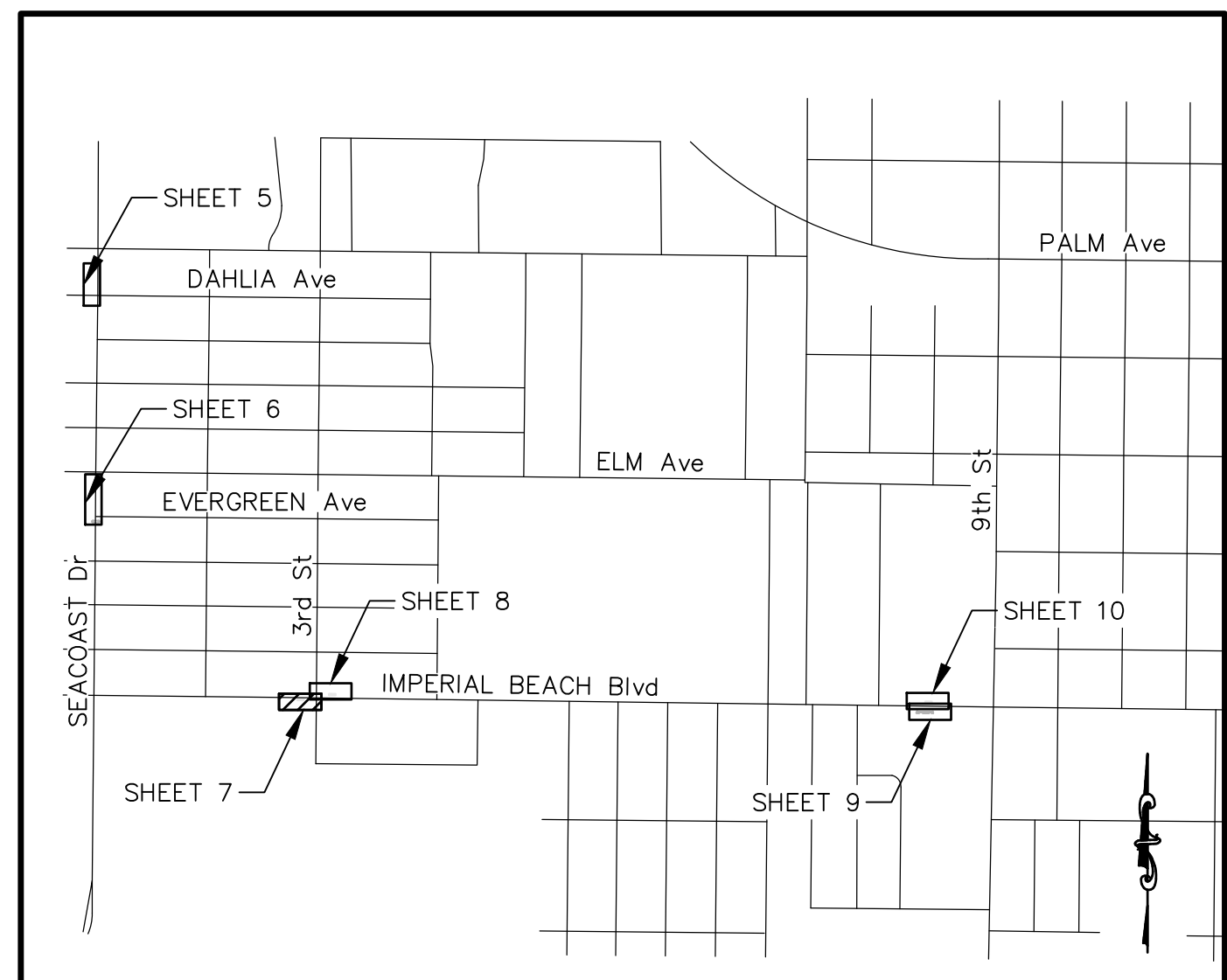

*Mark Tarrall*  
 MARK TARRALL R.C.E. NO. 71953 EXP. 12-31-23

DOKKEN ENGINEERING  
 1450 FRAZEE ROAD, SUITE 100  
 (858) 514-8377  
 DATE 10/31/2023

**NOTE:**  
 THE CITY OF SAN DIEGO ENGINEER DOES NOT CONSTITUTE APPROVAL OF THIS SHEET AS IT ONLY REFLECTS IMPROVEMENTS LOCATED WITHIN CITY OF IMPERIAL BEACH JURISDICTION.

<b>IMPROVEMENT PLANS FOR IRIS RAPID CORRIDOR AND STATION DESIGN IMPERIAL BEACH BLVD/CORONADO AVE</b>			
CITY OF IMPERIAL BEACH, CALIFORNIA		PROJECT NO. 686500	
SHEET 7 OF 89 SHEETS		V.T.M.	
DESCRIPTION	BY	APPROVED	DATE FILMED
CONFORMED	DE		6/20/22
	DE		
AS-BUILTS			
CONTRACTOR	DATE STARTED		
INSPECTOR	DATE COMPLETED		
			<b>07-D</b>

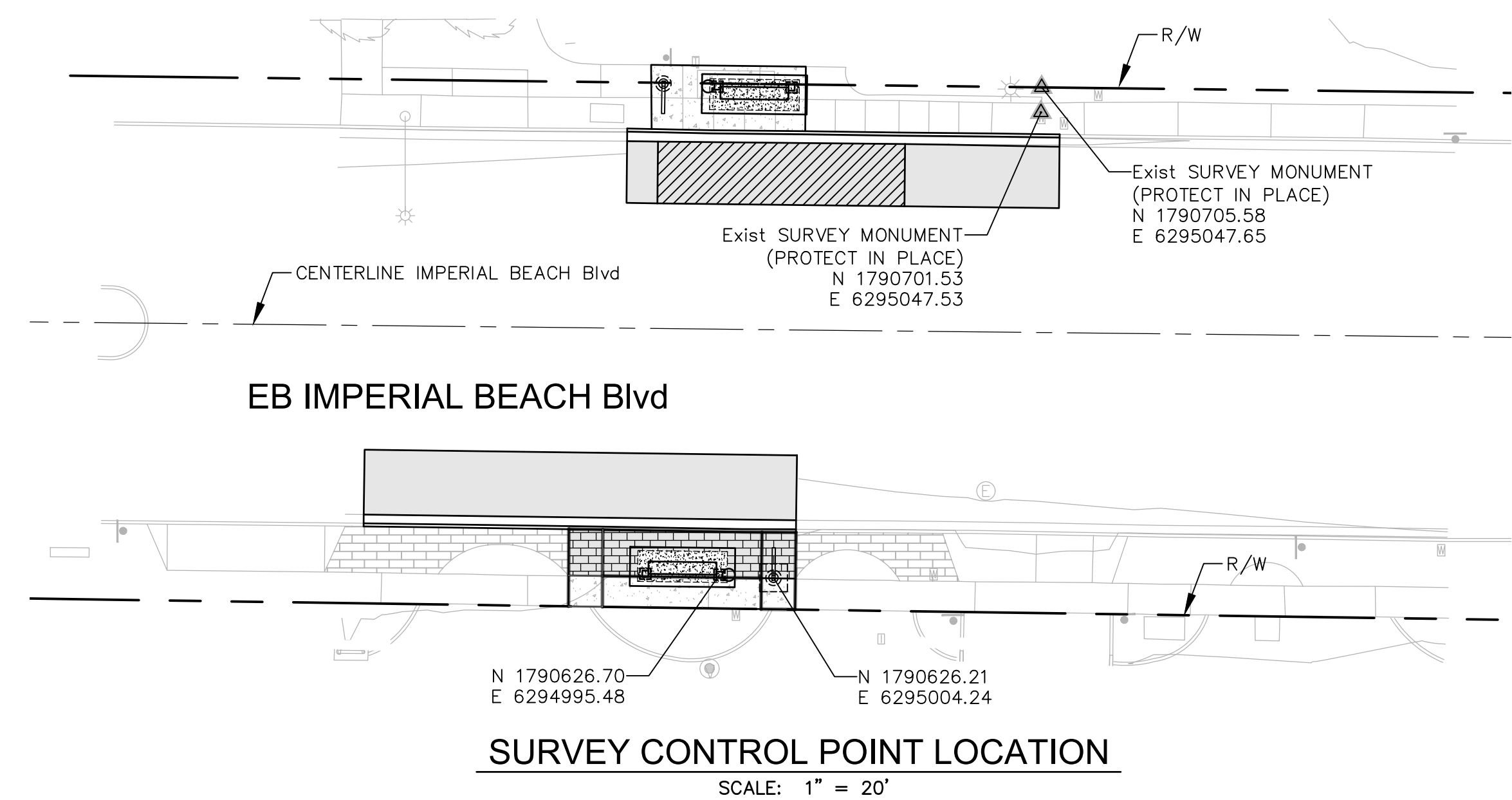
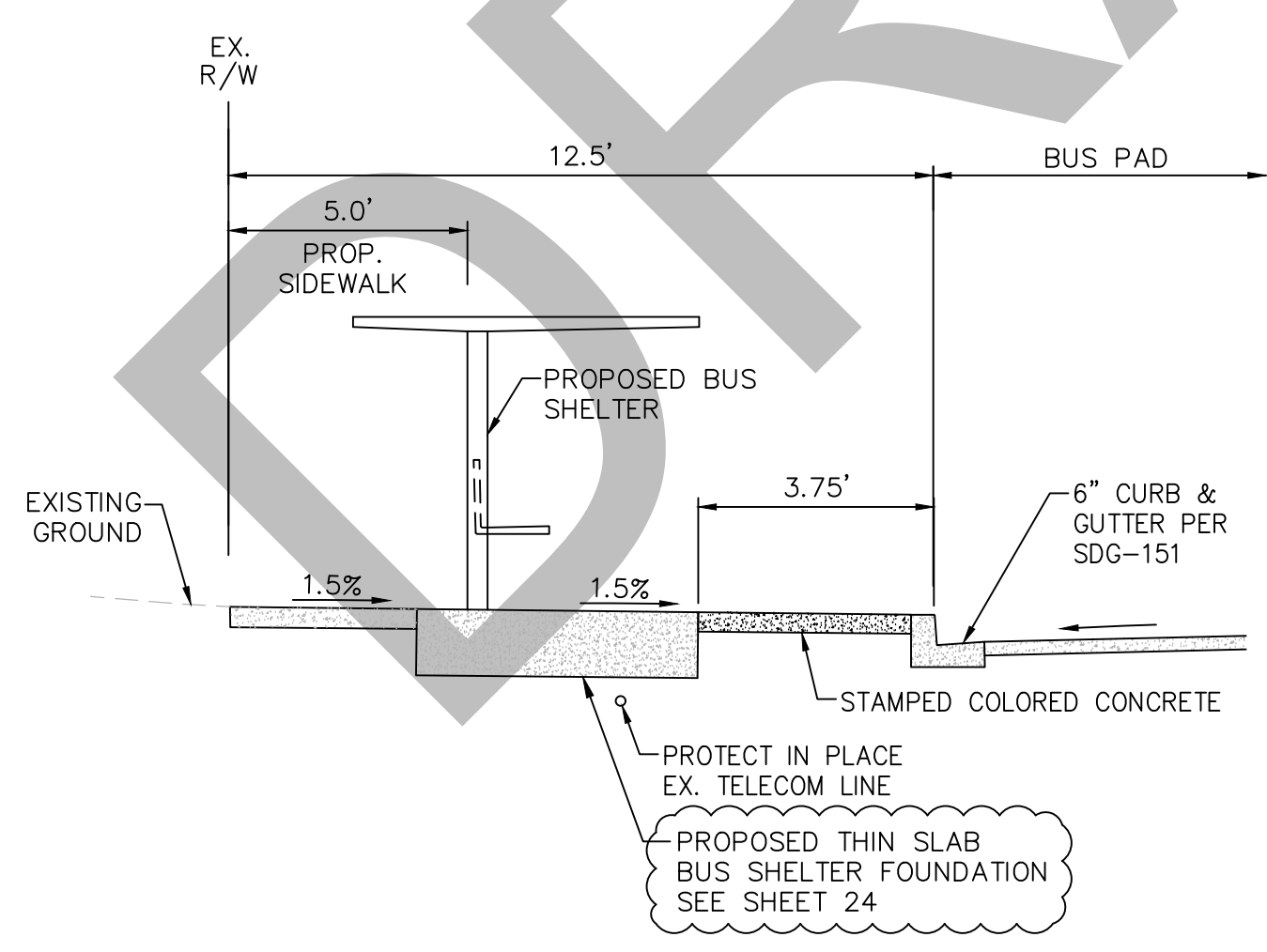
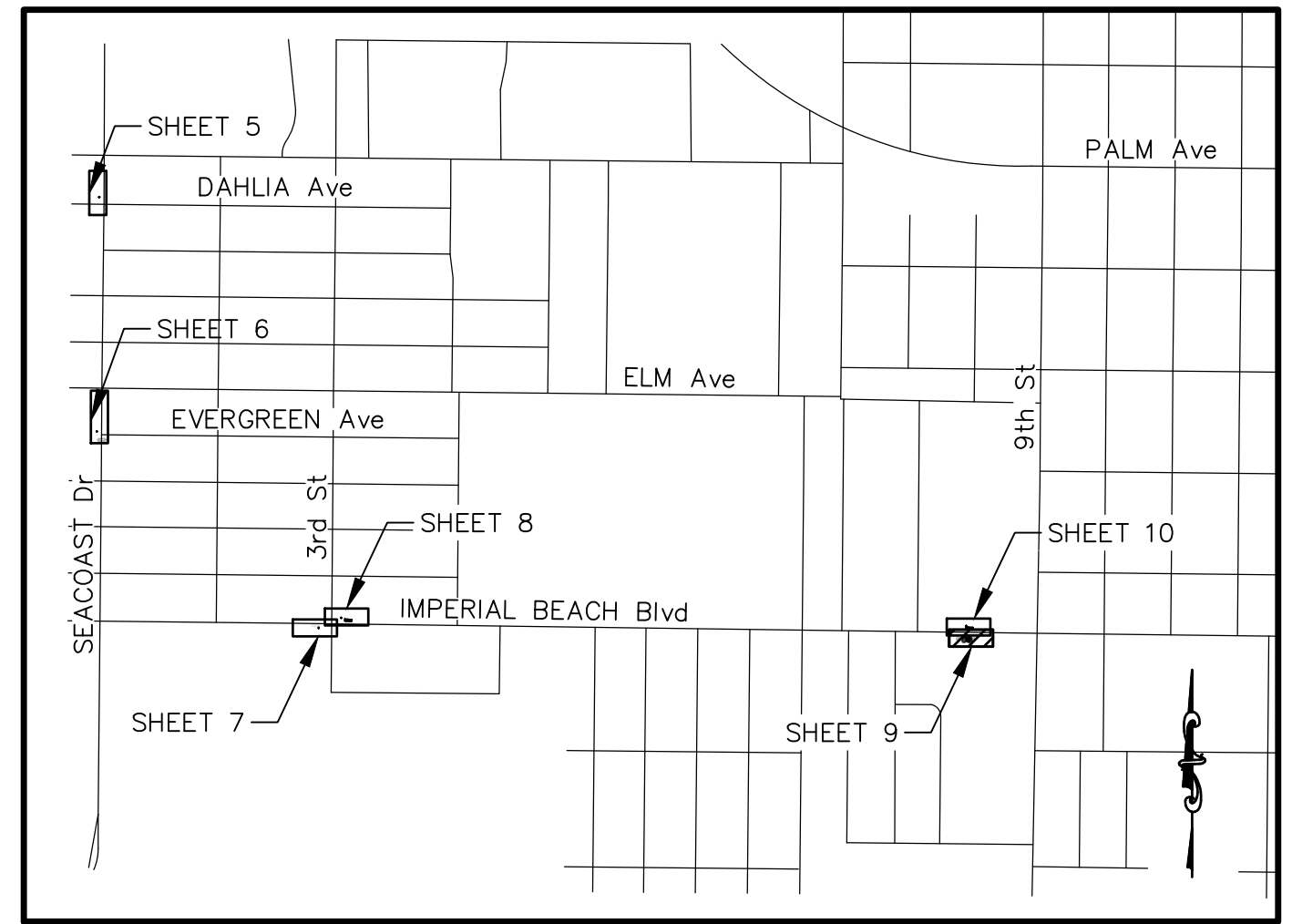
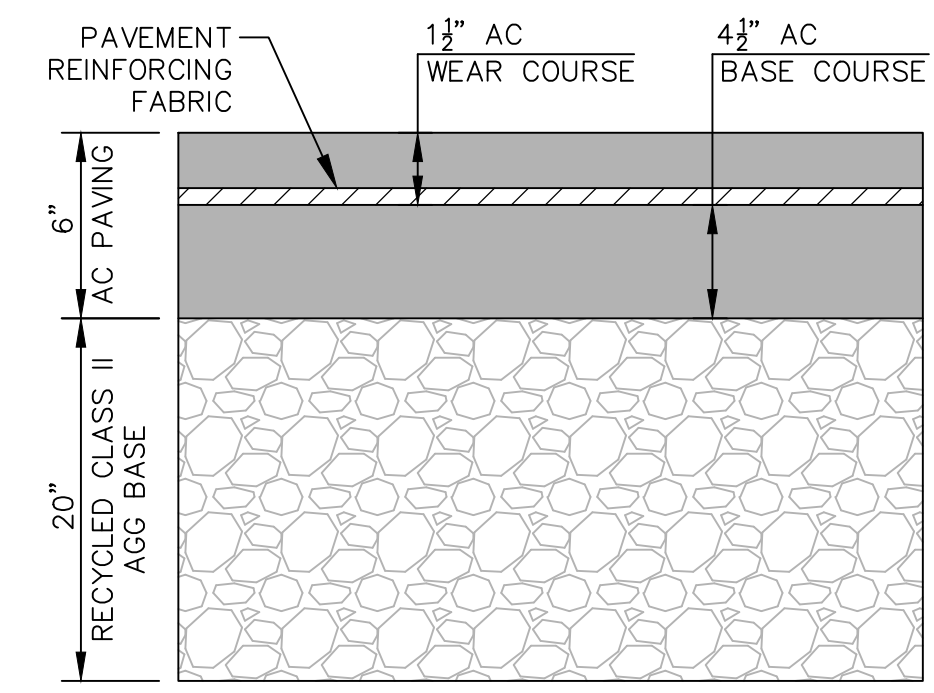
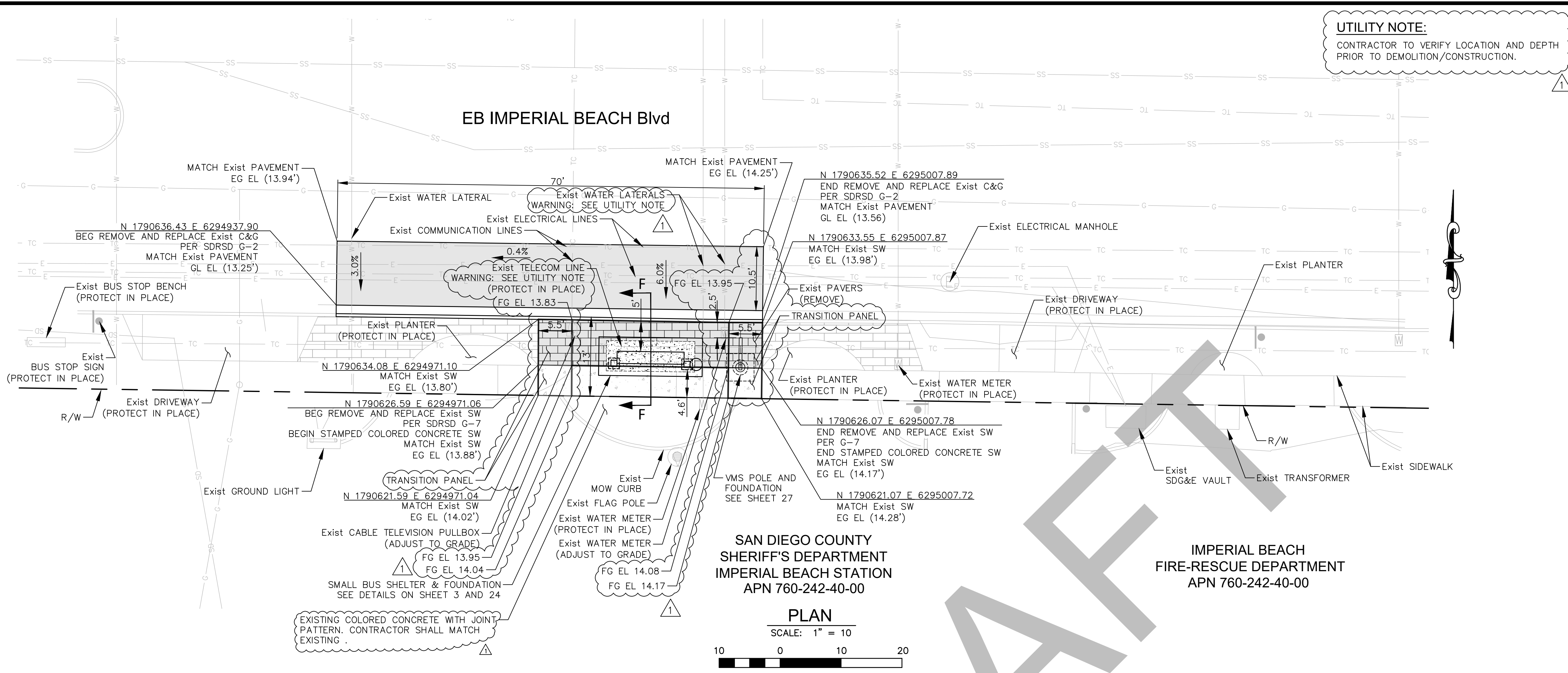

*Mark Tarrall*  
MARK TARRALL R.C.E. NO. 71953 EXP. 12-31-23

DOKKEN ENGINEERING  
1450 FRAZEE ROAD, SUITE 100  
(858) 514-8377

10/31/2023  
DATE

**NOTE:**  
THE CITY OF SAN DIEGO ENGINEER DOES NOT CONSTITUTE APPROVAL OF THIS SHEET AS IT ONLY REFLECTS IMPROVEMENTS LOCATED WITHIN CITY OF IMPERIAL BEACH JURISDICTION.

PRIVATE CONTRACT

**IMPROVEMENT PLANS FOR IRIS RAPID CORRIDOR AND STATION DESIGN IMPERIAL BEACH BLVD/CORONADO AVE**

CITY OF IMPERIAL BEACH, CALIFORNIA		PROJECT NO. 686500
SHEET 9 OF 89 SHEETS		V.T.M.
DESCRIPTION	BY	APPROVED
CONFORMED	DE	6/20/22
AS-BUILTS		
CONTRACTOR	DATE STARTED	
INSPECTOR	DATE COMPLETED	

1786-6299 NAD83 COORDINATES  
146-1739 LAMBERT COORDINATES

**09-D**

**TRAFFIC SIGNAL GENERAL NOTES:**

- PULL BOXES SHALL BE NO. 6 AND CONDUIT 3" UNLESS NOTED OTHERWISE.
- LOCATIONS OF ALL UNDERGROUND UTILITIES ARE APPROXIMATE. IT IS THE RESPONSIBILITY OF THE CONTRACTOR TO DETERMINE AND VERIFY THE EXACT LOCATIONS AND CONDITIONS ON THE JOB SITE.
- THE TRAFFIC SIGNAL CONTRACTOR SHALL OBTAIN A TRAFFIC CONTROL PLAN PERMIT FROM THE CITY OF SAN DIEGO DEVELOPMENT SERVICES DEPARTMENT PERMIT CENTER A MINIMUM OF FIVE (5) WORKING DAYS PRIOR TO START OF WORK.
- ALL TRAFFIC SIGNAL POLE FOUNDATIONS SHALL HAVE A 3" CONDUIT INSTALLED TO THE ADJACENT NO. 6 PULL BOX. THE CONTROLLER FOUNDATION SHALL HAVE A SPARE 3" CONDUIT INSTALLED TO THE ADJACENT NO. 6 PULL BOX FOR FUTURE USE AS SHOWN ON CONDUIT SCHEDULE. (NEEDS TO BE ADDED AS A NOTE AT THE BOTTOM OF THE CONDUIT SCHEDULE)
  - ALL CONDUIT CROSSINGS SHALL INCLUDE A MINIMUM OF TWO (2) 3" CONDUITS.
- THE TRAFFIC SIGNAL CONTRACTOR IS RESPONSIBLE FOR THE LAYOUT AND INSTALLATION OF LOOP DETECTORS, TRAFFIC STRIPING, PAVEMENT MARKINGS, PARKING REMOVAL AND TRAFFIC SIGNING (EXCEPT "G" SERIES STREET NAME SIGNS) AS SHOWN ON THESE PLANS.
  - THE TRAFFIC SIGNAL CONTRACTOR SHALL OBTAIN THE APPROVAL OF CITY RESIDENT TRAFFIC ENGINEER (ETS DIVISION) OF THE LOOP LOCATIONS PRIOR TO CUTTING, AS WELL AS, PRIOR TO ANY INSTALLATION AND/OR REMOVAL OF STRIPING, PAVEMENT MARKING, PARKING REMOVAL AND SIGN LOCATIONS.
  - THE TRAFFIC SIGNAL CONTRACTOR IS RESPONSIBLE FOR THE REMOVAL OF ALL UNNECESSARY AND CONFLICTING STRIPING AND PAVEMENT MARKINGS.
  - THE TRAFFIC SIGNAL CONTRACTOR IS RESPONSIBLE FOR REMOVAL OF ALL PAVEMENT MARK-OUTS.
- THE TRAFFIC SIGNAL CONTRACTOR SHALL NOT ERECT ANY SIGNAL STANDARDS MORE THAN THREE (3) WEEKS PRIOR TO SCHEDULED TRAFFIC SIGNAL TURN-ON.
- CONTRACTOR SHALL PROVIDE ALL CABLING AND CONDUCTORS NECESSARY TO PERFORM ALL FUNCTIONS SHOWN ON THESE PLANS.
- ALL POLES, CONDUIT, PULL BOXES, STRIPING AND LOOP DETECTOR LOCATIONS SHOWN ON THESE PLANS ARE APPROXIMATE. ACTUAL LOCATIONS SHALL BE DETERMINED BY FIELD CONDITIONS AT THE TIME ON CONSTRUCTION AND AS DIRECTED BY THE CITY OF SAN DIEGO.
- ROUTING AND LOCATIONS OF UNDERGROUND ELECTRICAL SYSTEM IS DIAGRAMMATIC AND SUBJECT TO APPROVAL OF THE CITY ELECTRICAL ENGINEER. UNDERGROUND ELECTRICAL LINES AND SUBSURFACE STRUCTURES MAY BE RELOCATED IF NECESSARY TO CLEAR OTHER EXISTING UNDERGROUND FACILITIES.
- ALL TREES AND SHRUBS SHALL BE TRIMMED OR REMOVED AS DETERMINED BY THE CITY RESIDENT ENGINEER AS REQUIRED TO MAINTAIN SIGNAL HEAD VISIBILITY AND SIGHT DISTANCE.
- ALL VEHICLE HEADS SHALL BE 12" L.E.D WITH AN INCANDESCENT LOOK AND BACKPLATES.
- ALL VEHICLE DETECTOR LOOPS SHALL BE TYPE "E" AS SHOWN ON THIS PLAN.
  - DETECTOR LOOPS SHALL BE 6" DIAMETER WITH 10' SPACING AND POSITIONED IN CENTER OF LANE UNLESS OTHERWISE SHOWN.
  - FRONT DETECTOR LOOPS SHALL BE TYPE "E" MODIFIED LOOPS PER SDE-104.
  - ALL LOOP LAYOUTS SHALL INCLUDE LAYOUT OF HOMERUN LINES, WHICH MUST BE APPROVED PRIOR TO INSTALLATION
  - BICYCLE DETECTOR LOOPS SHALL BE TYPE Q.
- PEDESTRIAN SIGNAL INDICATIONS AND PUSH BUTTONS SHALL BE INTERNATIONAL SYMBOLS. PEDESTRIAN SIGNAL INDICATIONS SHALL BE 16" X 18" L.E.D COUNTDOWN TIMER WITH AN INCANDESCENT LOOK. PEDESTRIAN PUSH BUTTONS SHALL BE 2" PER ADA REQUIREMENTS.
- ALL CROSSWALKS SHALL BE CONTINENTAL TYPE PER SDM-116.
- PEDESTRIAN PUSH BUTTON HOUSING COLOR SHALL MATCH COLOR NO. 33538 OF FED-STD-595 WHEN PEDESTRIAN PUSH BUTTONS ARE PLACED ON A TRAFFIC SIGNAL POLE.

**STRIPING AND SIGNING GENERAL NOTES:**

- INSTALLATION OF ALL STRIPING, SIGNS AND PAVEMENT MARKERS SHALL BE THE RESPONSIBILITY OF THE CONTRACTOR.
- ALL STRIPING AND SIGNING SHALL CONFORM TO THE MOST RECENTLY ADOPTED EDITION OF THE FOLLOWING MANUALS:
 

DESCRIPTION	EDITION	DOCUMENT NO.
STANDARD SPECIFICATIONS FOR PUBLIC WORKS CONSTRUCTION (GREENBOOK), 2018 EDITION	2018	PWPI010119-01
CITY OF SAN DIEGO STANDARD DRAWINGS FOR PUBLIC WORKS CONSTRUCTION, 2018 EDITION	2018	PWPI010119-03
CALIFORNIA DEPARTMENT OF TRANSPORTATION MANUAL ON UNIFORM TRAFFIC CONTROL DEVICES (REVISION 3), 2014 EDITION	2018	PWPI030119-07
- ALL SIGNING AND STRIPING IS SUBJECT TO THE APPROVAL OF THE CITY ENGINEER PRIOR TO INSTALLATION AND/OR REMOVAL.
- THE CONTRACTOR SHALL REMOVE ALL CONFLICTING STRIPING, PAVEMENT MARKINGS AND LEGENDS BY SANDBLASTING AND/OR GRINDING WITH THE SEAL. ANY DEBRIS SHALL BE PROMPTLY REMOVED BY THE CONTRACTOR.
- SIGN POSTS SHALL BE INSTALLED WITH SQUARE PERFORATED STEEL TUBING WITH A BREAKAWAY BASE PER CITY OF SAN DIEGO STANDARD DRAWING SDM-104.
- ALL RAISED MEDIAN NOSES SHALL BE PAINTED YELLOW.
- ALL SIGNS SHOWN ON THE STRIPING AND SIGNING PLANS SHALL BE NEW SIGNS PROVIDED AND INSTALLED BY THE CONTRACTOR, EXCEPT FOR EXISTING SIGNS SPECIFICALLY INDICATED TO BE RELOCATED OR TO REMAIN.
- MARKED CROSSWALKS SHALL HAVE AN INSIDE DIMENSION OF 10 FEET UNLESS INDICATED OTHERWISE.
- ALL LIMIT LINES/STOP LINES, CROSSWALK LINES, PAVEMENT LEGENDS, AND ARROWS (EXCEPT WITHIN BIKE LANES) SHALL BE THERMOPLASTIC.
- THE CONTRACTOR SHALL NOTIFY THE CITY TRAFFIC ENGINEER AT (858) 495-4742 A MINIMUM OF FIVE (5) WORKING DAYS PRIOR TO AND UPON COMPLETION OF STRIPING AND SIGNING.

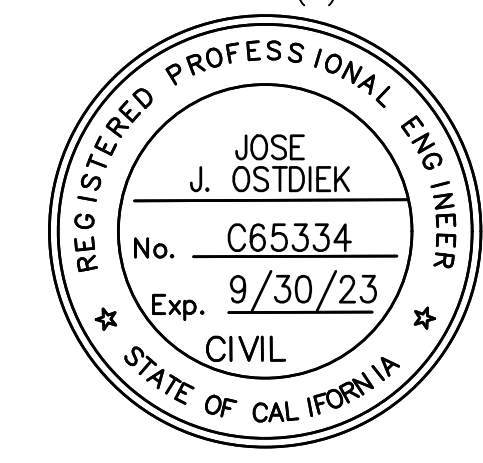

*Jose J. OstDiek*  
 JOSE J. OSTDIEK R.C.E. NO. 65334 EXP. 09-30-23

DOKKEN ENGINEERING  
 1450 FRAZEE ROAD, SUITE 100  
 (858) 514-8377  
 DATE 10/31/2023

**LEGEND:**

- AB** ABANDON, IF APPLIED TO CONDUIT, REMOVE CONDUCTORS
- BC** REPLACE PULL BOX IN EXISTING CONDUIT RUN WITH A #6 PULL BOX
- CB** INSTALL CONDUIT INTO EXISTING PULL BOX.
- CC** CONNECT NEW AND EXISTING CONDUIT. REMOVE EXISTING CONDUCTORS AND INSTALL CONDUCTORS AS INDICATED
- RC** EQUIPMENT OR MATERIAL TO BE REMOVED AND BECOME THE PROPERTY OF THE CONTRACTOR
- RS** REMOVE AND SALVAGE EQUIPMENT
- RL** RELOCATE EQUIPMENT
- SC** SPLICE NEW TO EXISTING CONDUCTORS

**BUS STOP AND TRANSIT CENTER GENERAL NOTES:**

- ALL PULL BOXES SHALL BE NO. 6 UNLESS OTHERWISE NOTED
- CONDUIT TRENCHING SHALL CONFORM TO THE CITY OF SAN DIEGO STANDARD DRAWINGS SDG-117 AND SDG-118
- INSTALL CONDUIT BY HORIZONTAL DIRECTIONAL DRILLING WHERE INDICATED.

**TRENCHING AND DIRECTIONAL DRILLING GENERAL NOTES:**

- CONTRACTOR RESPONSIBLE FOR POTHOLING AND PATCHING ALL EXISTING UTILITIES WHEN PERFORMING HORIZONTAL DIRECTIONAL DRILLING.
- CONDUIT DEPTH TO BE 30" MINIMUM BELOW GRADE.
- THE CONTRACTOR SHALL REPAIR OR REPLACE ALL EXISTING IMPROVEMENTS WITHIN THE RIGHT-OF-WAY WHICH ARE NOT DESIGNATED FOR REMOVAL (E.G., CURBS, SIDEWALKS, DRIVEWAYS, FENCES, WALLS, SIGNS, UTILITY INSTALLATIONS, PAVEMENT, STRUCTURES, ETC.) WHICH ARE DAMAGED OR REMOVED AS A RESULT OF ITS OPERATIONS.

**NOTES TO CONTRACTOR EXISTING UTILITES:**

- CONTRACTOR TO VERIFY LOCATION AND DEPTH PRIOR TO DEMOLITION/CONSTRUCTION.

**BUS STOP AND TRANSIT CENTER SYMBOLS:**

- ELECTRICAL CONDUIT
- COMMUNICATION CONDUIT
- EXISTING PULL BOX, E=ELECTRICAL, C=COMMUNICATION
- PROPOSED No.6 PULL BOX, E=ELECTRICAL, C=COMMUNICATION
- EXISTING SERVICE EQUIPMENT ENCLOSURE
- PROPOSED SERVICE EQUIPMENT ENCLOSURE
- EXISTING BUS PLATFORM LIGHT
- PROPOSED PIER PLAZA LIGHT
- EXISTING PIER PLAZA LIGHT
- PROPOSED VARIABLE MESSAGE SIGN
- EXISTING SPLICE VAULT

**ABBREVIATIONS:**

SMFO 24 STRAND SINGLE MODE FIBER OPTIC CABLE

PRIVATE CONTRACT

**ELECTRICAL NOTES FOR IRIS RAPID CORRIDOR AND STATION DESIGN**  
 IMPERIAL BEACH BLVD/CORONADO AVE

CITY OF SAN DIEGO, CALIFORNIA  
 DEVELOPMENT SERVICES DEPARTMENT  
 SHEET 33 OF 69 SHEETS

PROJECT NO. 686500

FOR CITY ENGINEER	DATE	V.T.M.
DESCRIPTION	BY	APPROVED
CONFORMED	DE	6/20/22
AS-BUILTS		
CONTRACTOR	DATE STARTED	
INSPECTOR	DATE COMPLETED	

1786-6299 NAD83 COORDINATES  
 146-1739 LAMBERT COORDINATES

**42363-33-D**

1 REVISED BUS STOP AND TC NOTES, SYMBOLS

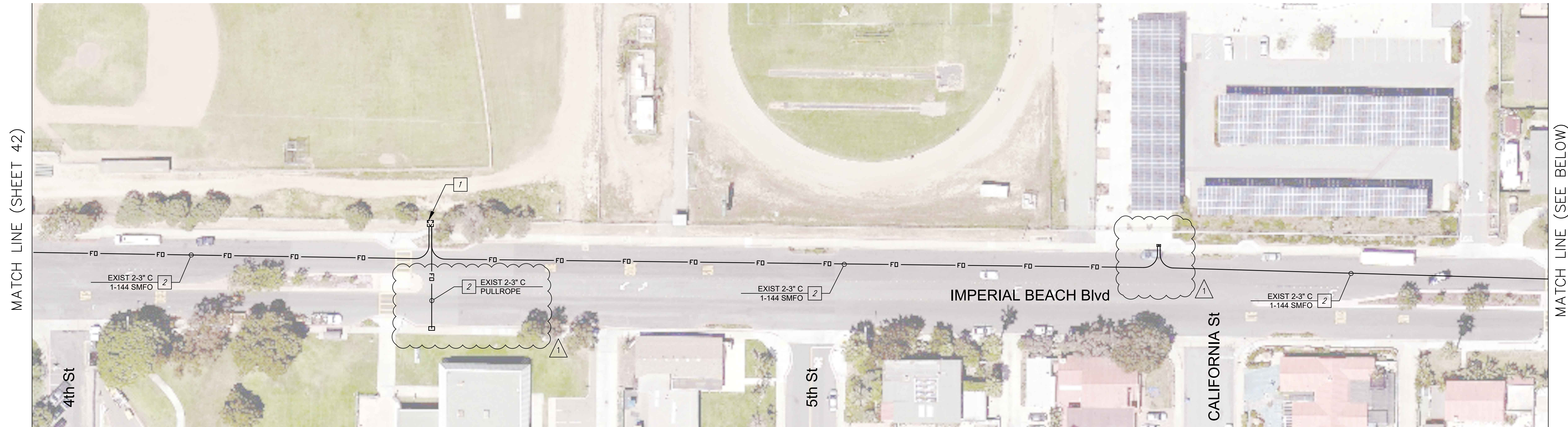

**CONSTRUCTION NOTES**

- 1 EXISTING SPLICE VAULT TO REMAIN.
- 2 INSTALL 1-24 STRAND SMFO IN CONDUIT. LABEL AS "SAN DIEGO MTS"

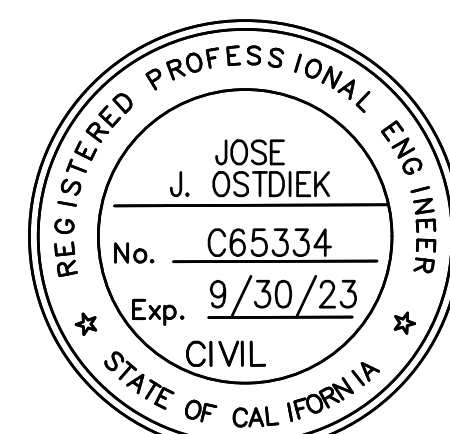
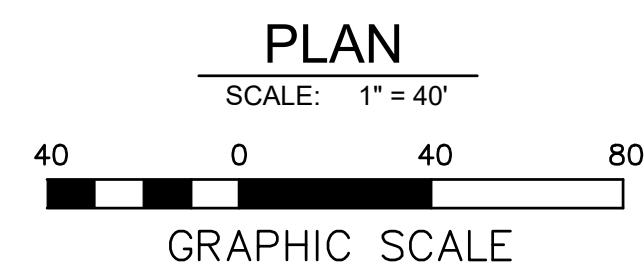

*Jose J. Ostdiek*  
JOSE J. OSTDIEK R.C.E. NO. 65334 EXP. 09-30-23

10/31/2023  
DATE

DOKKEN ENGINEERING  
1450 FRAZEE ROAD, SUITE 100  
(858) 514-8377

**NOTE:**  
THE CITY OF SAN DIEGO ENGINEER DOES NOT CONSTITUTE APPROVAL OF THIS SHEET AS IT ONLY REFLECTS IMPROVEMENTS LOCATED WITHIN CITY OF IMPERIAL BEACH JURISDICTION.

PRIVATE CONTRACT				
<b>FIBER OPTIC CABLE SYSTEMS FOR: IRIS RAPID CORRIDOR AND STATION DESIGN IMPERIAL BEACH BLVD/CORONADO AVE</b>				
CITY OF IMPERIAL BEACH, CALIFORNIA				PROJECT NO. 686500
SHEET 43 OF 69 SHEETS				V.T.M.
DESCRIPTION	BY	APPROVED	DATE	FILMED
CONFORMED	DE		6/20/22	
	DE			
AS-BUILTS				
CONTRACTOR		DATE STARTED		
INSPECTOR		DATE COMPLETED		
				1786-6299 NAD83 COORDINATES 146-1739 LAMBERT COORDINATES
				<b>43-D</b>



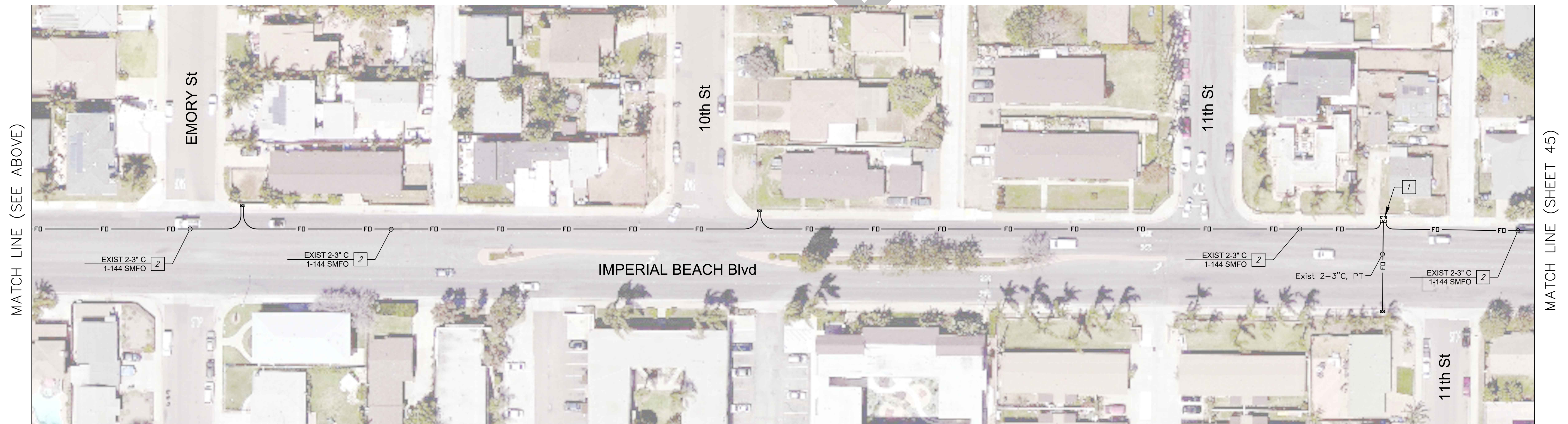
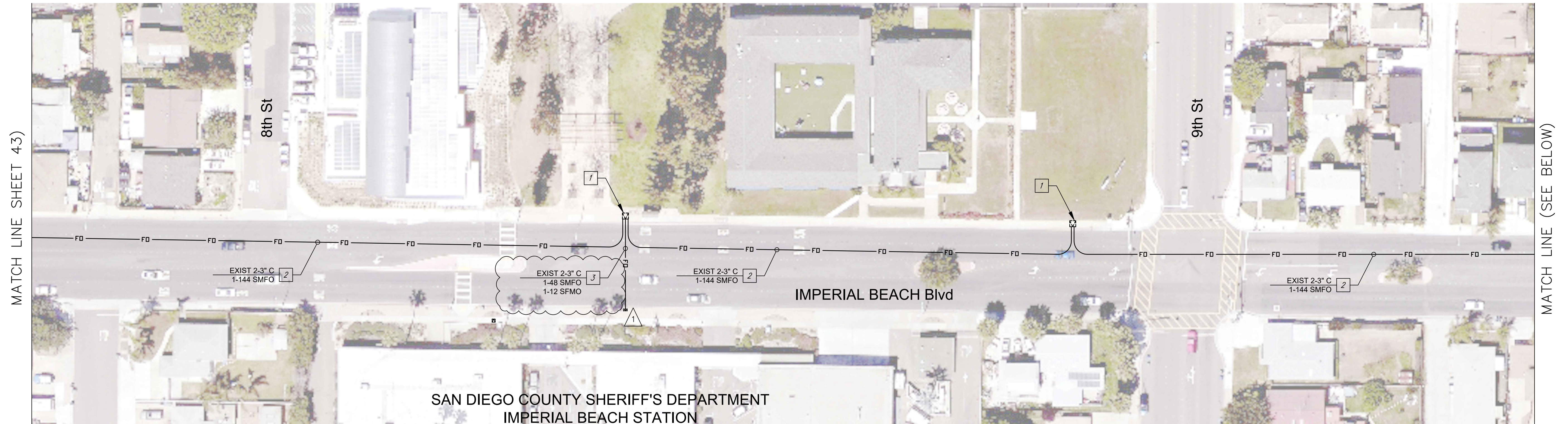

- CONSTRUCTION NOTES**
- 1 EXISTING SPLICE VAULT TO REMAIN.
  - 2 INSTALL 1-24 STRAND SMFO IN CONDUIT. LABEL AS "SAN DIEGO MTS"
  - 3 INSTALL 1-12 STRAND SMFO DROP CABLE. LABEL AS "SAN DIEGO MTS"

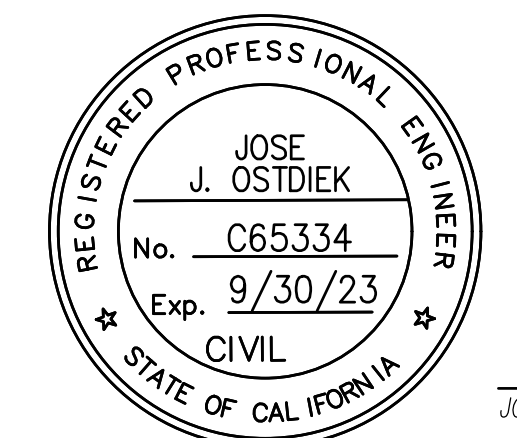
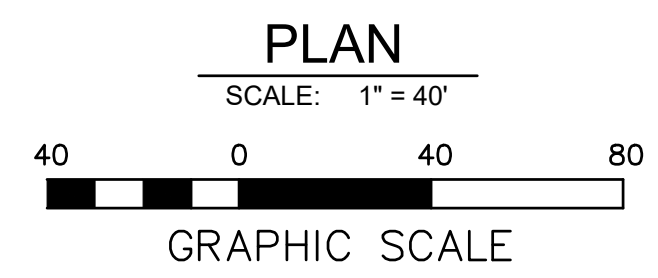

*Jose J. Ostdiek*  
JOSE J. OSTDIEK R.C.E. NO. 65334 EXP. 09-30-23

DOKKEN ENGINEERING  
1450 FRAZEE ROAD, SUITE 100  
(858) 514-8377  
10/31/2023  
DATE

**NOTE:**  
THE CITY OF SAN DIEGO ENGINEER DOES NOT CONSTITUTE APPROVAL OF THIS SHEET AS IT ONLY REFLECTS IMPROVEMENTS LOCATED WITHIN CITY OF IMPERIAL BEACH JURISDICTION.

PRIVATE CONTRACT			
<b>FIBER OPTIC CABLE SYSTEMS FOR: IRIS RAPID CORRIDOR AND STATION DESIGN IMPERIAL BEACH BLVD/CORONADO AVE</b>			
CITY OF IMPERIAL BEACH, CALIFORNIA		PROJECT NO. 686500	
SHEET 44 OF 69 SHEETS		V.T.M.	
DESCRIPTION	BY	APPROVED	DATE FILMED
CONFORMED	DE		6/20/22
	DE		
AS-BUILTS			
CONTRACTOR		DATE STARTED	
INSPECTOR		DATE COMPLETED	
		1786-6299 NAD83 COORDINATES	
		146-1739 LAMBERT COORDINATES	
<b>44-D</b>			

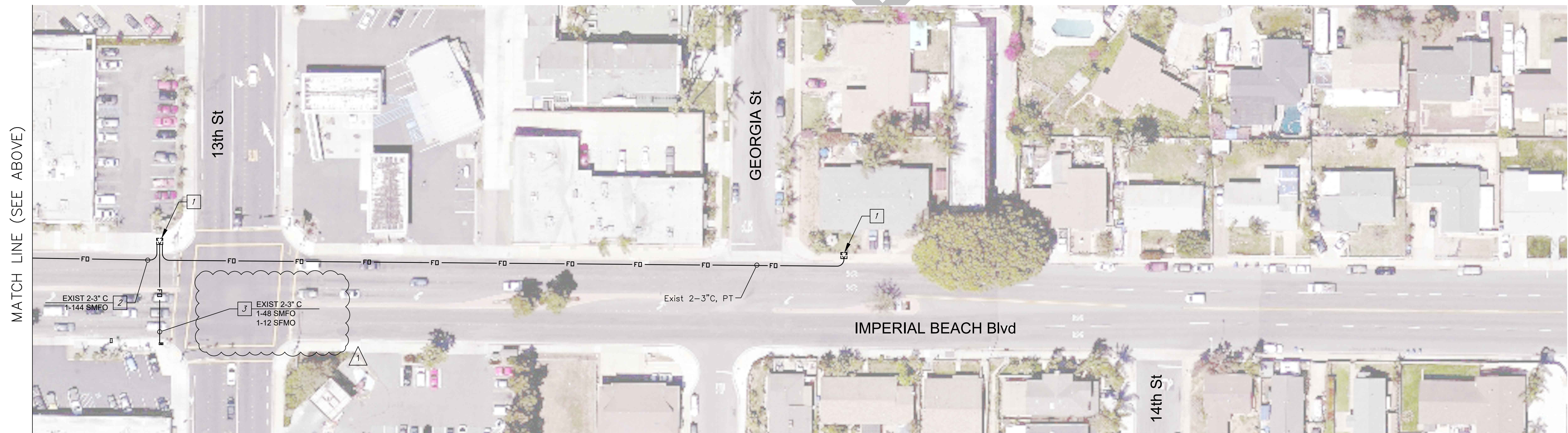
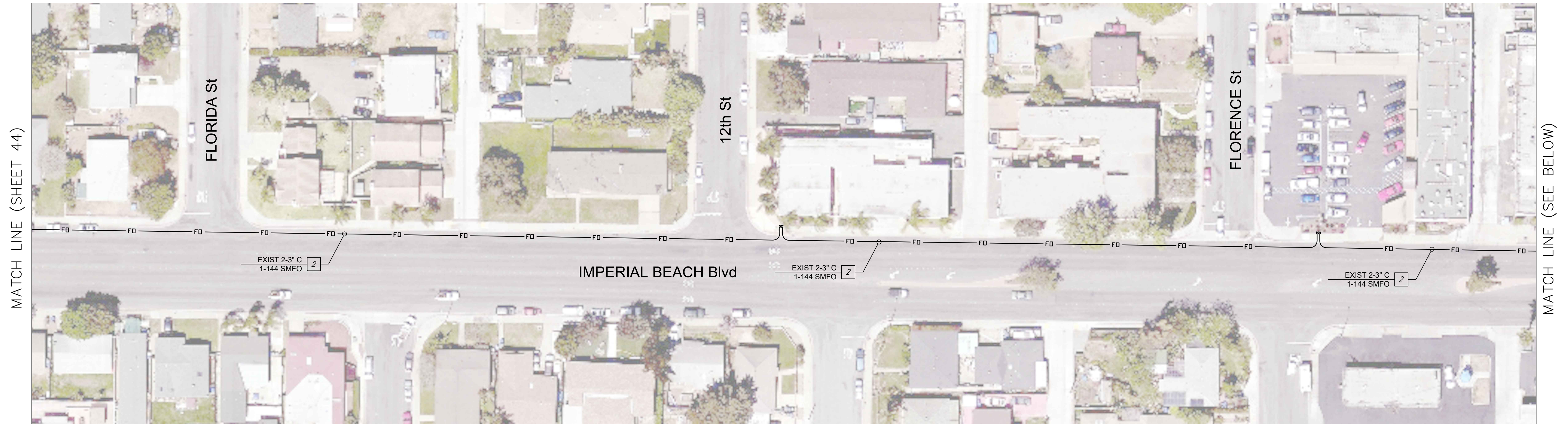

**CONSTRUCTION NOTES**

- 1 EXISTING SPLICE VAULT TO REMAIN.
- 2 INSTALL 1-24 STRAND SMFO IN CONDUIT. LABEL AS "SAN DIEGO MTS"
- 3 INSTALL 1-12 STRAND SMFO DROP CABLE. LABEL AS "SAN DIEGO MTS"

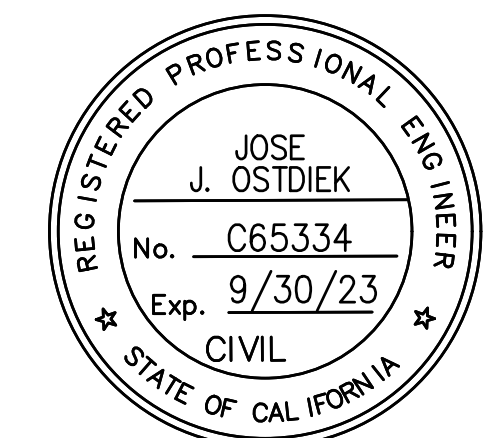
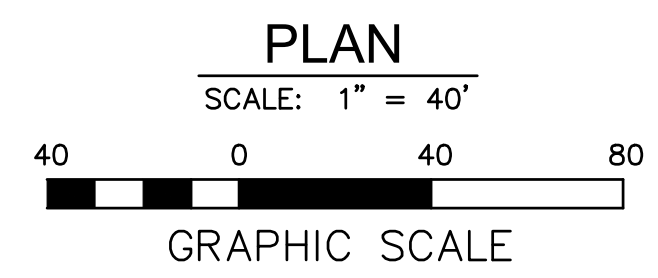

*Jose J. OstDiek*  
 JOSE J. OSTDIEK R.C.E. NO. 65334 EXP. 09-30-23

DOKKEN ENGINEERING  
 1450 FRAZEE ROAD, SUITE 100  
 (858) 514-8377  
 10/31/2023  
 DATE

**NOTE:**  
 THE CITY OF SAN DIEGO ENGINEER DOES NOT CONSTITUTE APPROVAL OF THIS SHEET AS IT ONLY REFLECTS IMPROVEMENTS LOCATED WITHIN CITY OF IMPERIAL BEACH JURISDICTION.

PRIVATE CONTRACT				
<b>FIBER OPTIC CABLE SYSTEMS FOR: IRIS RAPID CORRIDOR AND STATION DESIGN IMPERIAL BEACH BLVD/CORONADO AVE</b>				
CITY OF IMPERIAL BEACH, CALIFORNIA				PROJECT NO. 686500
SHEET 45 OF 69 SHEETS				V.T.M.
DESCRIPTION	BY	APPROVED	DATE	FILMED
CONFORMED	DE		6/20/22	
	DE			
AS-BUILTS				
CONTRACTOR		DATE STARTED		
INSPECTOR		DATE COMPLETED		
				<b>45-D</b>



DRAFT

**CONSTRUCTION NOTES**

- 1 EXISTING SPLICE VAULT TO REMAIN.
- 2 INSTALL 1-24 STRAND SMFO IN CONDUIT.
- 3 EXISTING PULL BOX WITH 2" CONDUIT INTO LIFEGUARD CENTER. TERMINATE 1-24 STRAND SMFO IN 24 PORT FIBER OPTIC DISTRIBUTION UNIT SEE DETAIL ON SHEET 4X-X

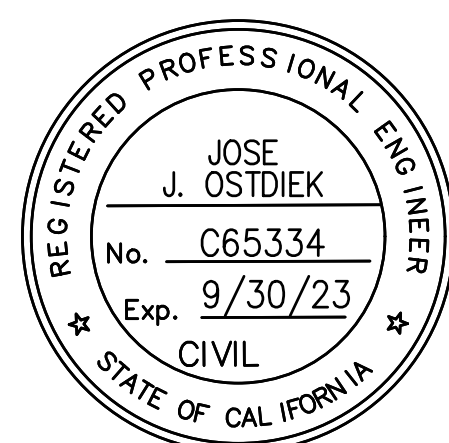
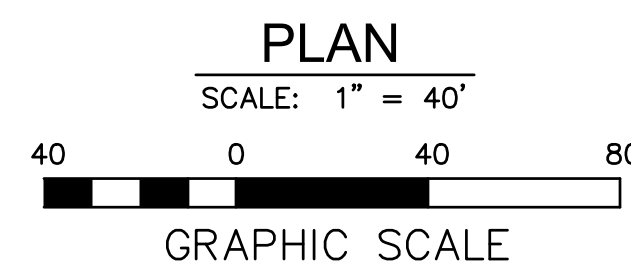

*Jose J. Ostdiek*  
JOSE J. OSTDIEK R.C.E. NO. 65334 EXP. 09-30-23

DOKKEN ENGINEERING  
1450 FRAZEE ROAD, SUITE 100  
(858) 514-8377

10/31/2023  
DATE

**NOTE:**  
THE CITY OF SAN DIEGO ENGINEER DOES NOT CONSTITUTE APPROVAL OF THIS SHEET AS IT ONLY REFLECTS IMPROVEMENTS LOCATED WITHIN CITY OF IMPERIAL BEACH JURISDICTION.

PRIVATE CONTRACT <b>FIBER OPTIC CABLE SYSTEMS FOR: IRIS RAPID CORRIDOR AND STATION DESIGN IMPERIAL BEACH BLVD/CORONADO AVE</b>				
CITY OF IMPERIAL BEACH, CALIFORNIA SHEET <b>67</b> OF <b>69</b> SHEETS			PROJECT NO. <u>686500</u>	
			V.T.M. _____	
DESCRIPTION	BY	APPROVED	DATE	FILMED
AS-BUILTS				
CONTRACTOR		DATE STARTED		
INSPECTOR		DATE COMPLETED		
				<b>67-D</b>

**SYMBOLS:**

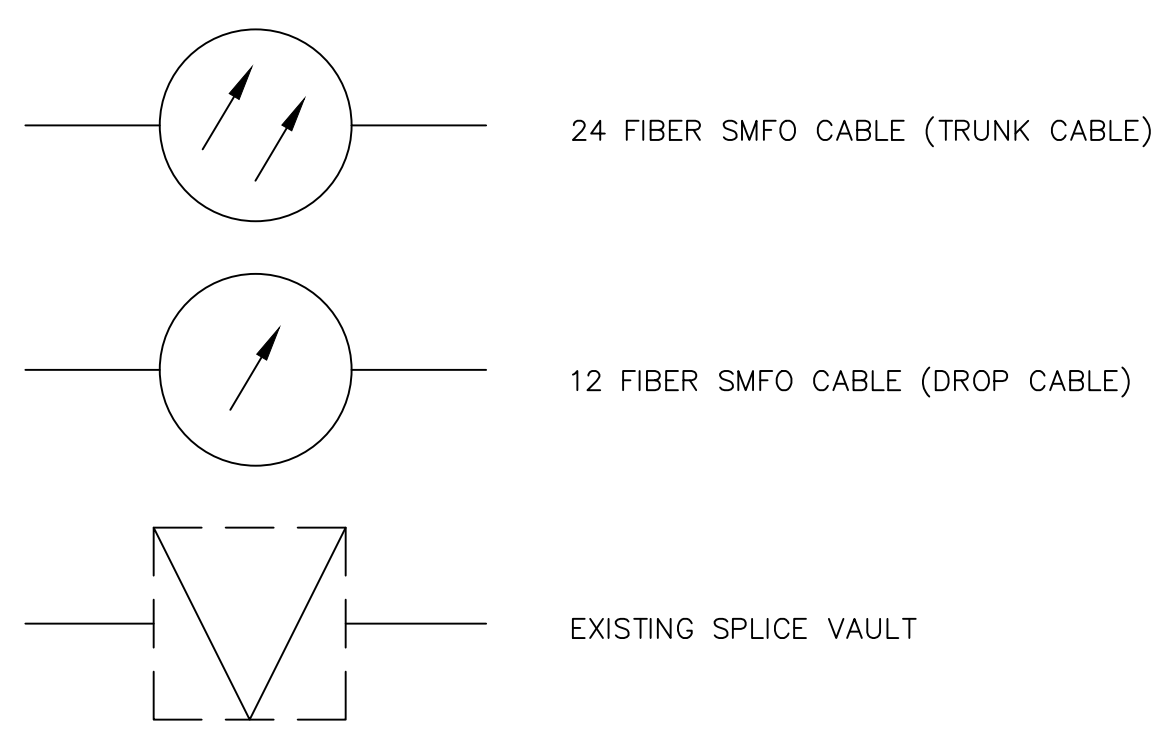

**NOTE:**

1. SLACK REQUIREMENTS: A MINIMUM OF 100 FEET OF SLACK MUST BE COILED INSIDE SPLICE VAULTS. A MINIMUM OF 25 FEET OF SLACK CABLE MUST BE COILED INSIDE #6 PULL BOXES.
2. NOT ALL SPLICE VAULTS SHOWN SEE FIBER OPTIC PLANS FOR DETAILS.
3. SEE TYPICAL NETWORK DEVICE (VMS) CONNECTION VIA SINGLE MODE FIBER OPTIC CABLE ON SHEET 69.

**NOTE:**

1. COIL 50 FT OF CABLE IN PULLBOX FOR FUTURE

**ABBREVIATIONS:**

VMS VARIABLE MESSAGE SIGN

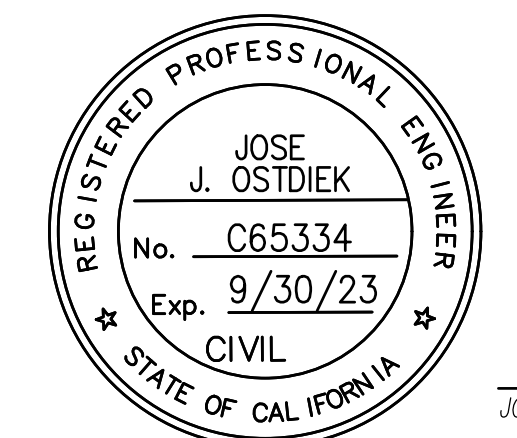
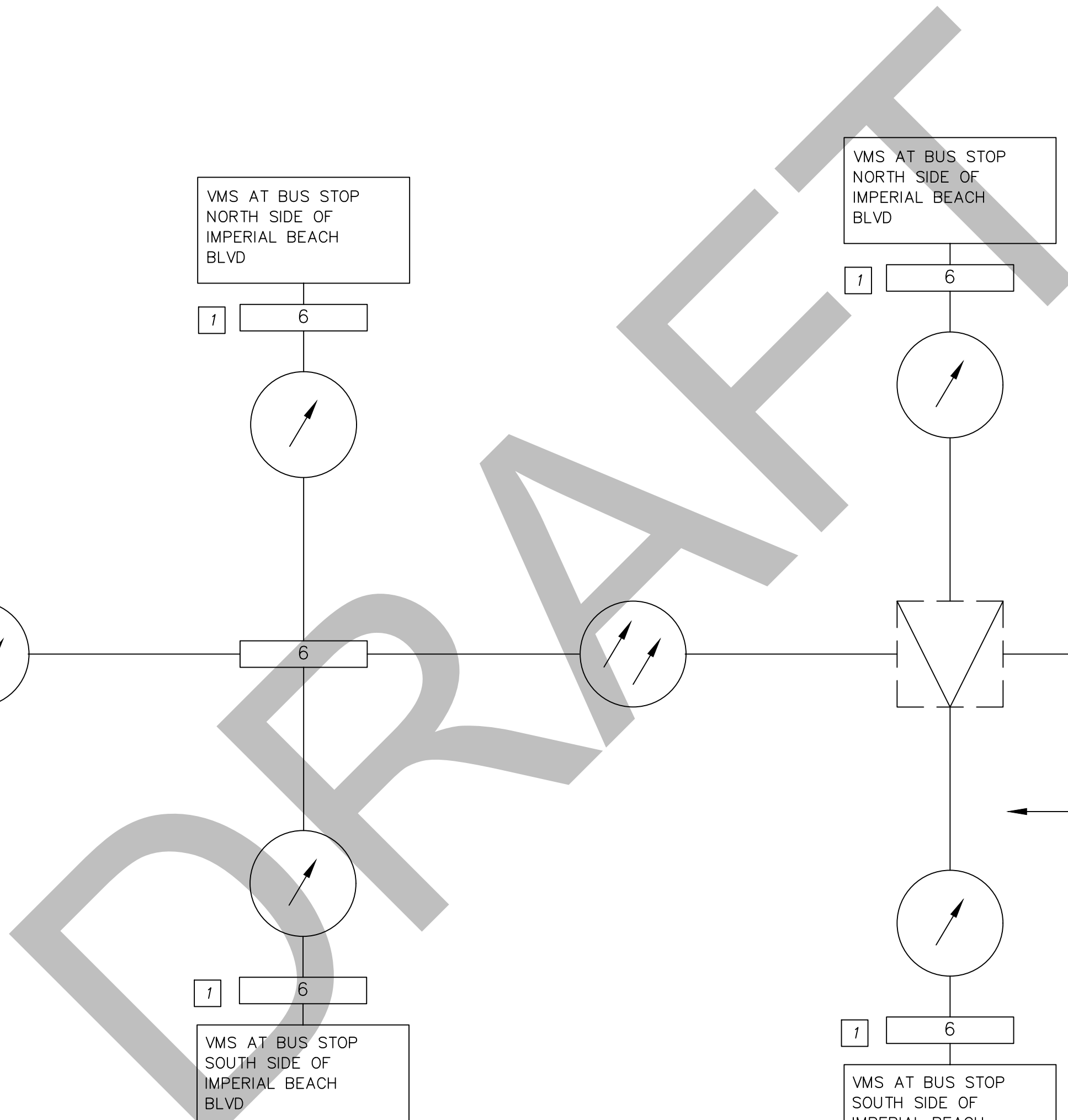
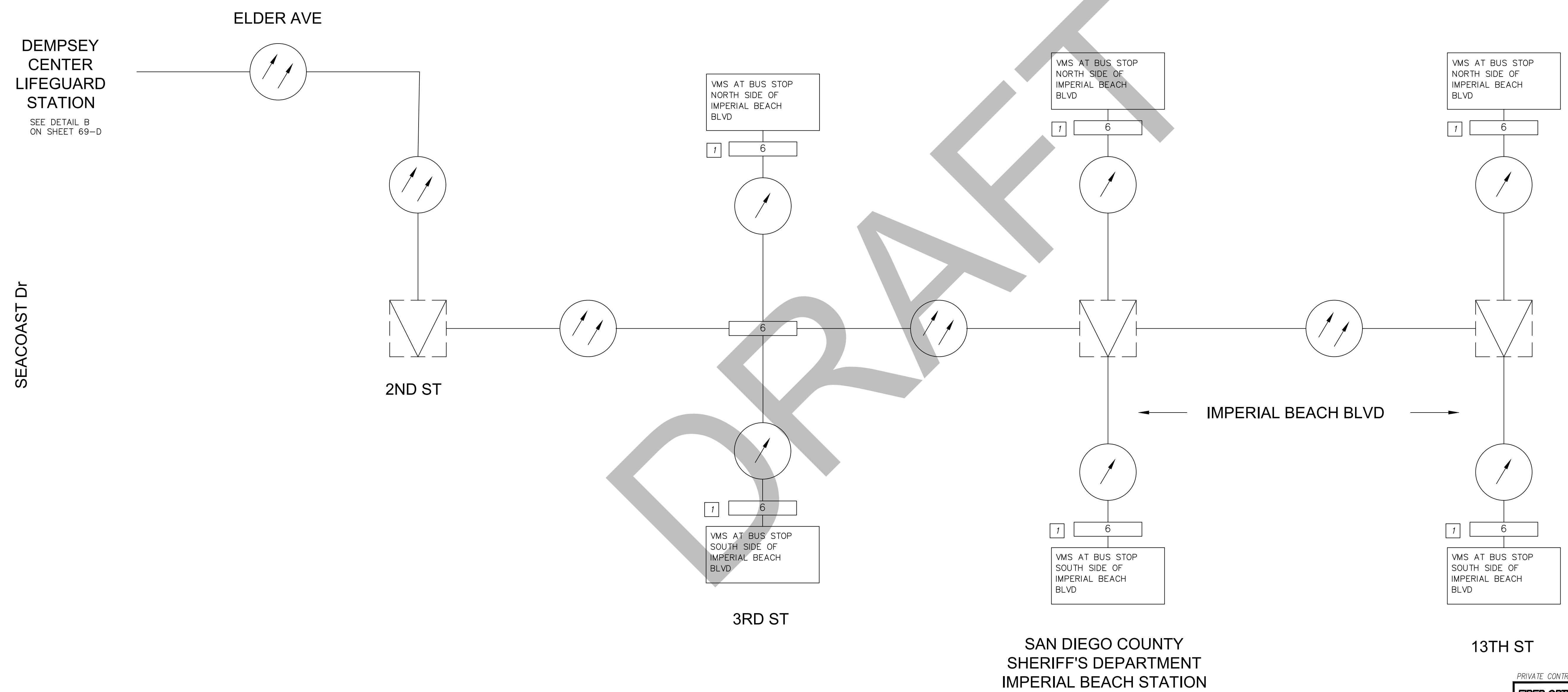

*Jose J. Ostdiek*  
 JOSE J. OSTDIEK R.C.E. NO. 65334 EXP. 09-30-23

DOKKEN ENGINEERING  
 1450 FRAZEE ROAD, SUITE 100  
 (858) 514-8377  
 10/31/2023  
 DATE

PRIVATE CONTRACT			
FIBER OPTIC CABLE SYSTEMS FOR: <b>IRIS RAPID CORRIDOR AND STATION DESIGN</b> IMPERIAL BEACH BLVD/CORONADO AVE			
CITY OF IMPERIAL BEACH, CALIFORNIA		PROJECT NO. 686500	
SHEET 68 OF 69 SHEETS		V.T.M.	
DESCRIPTION	BY	APPROVED	DATE FILMED
AS-BUILTS			
CONTRACTOR		DATE STARTED	
INSPECTOR		DATE COMPLETED	
			<b>68-D</b>

NEW SHEET

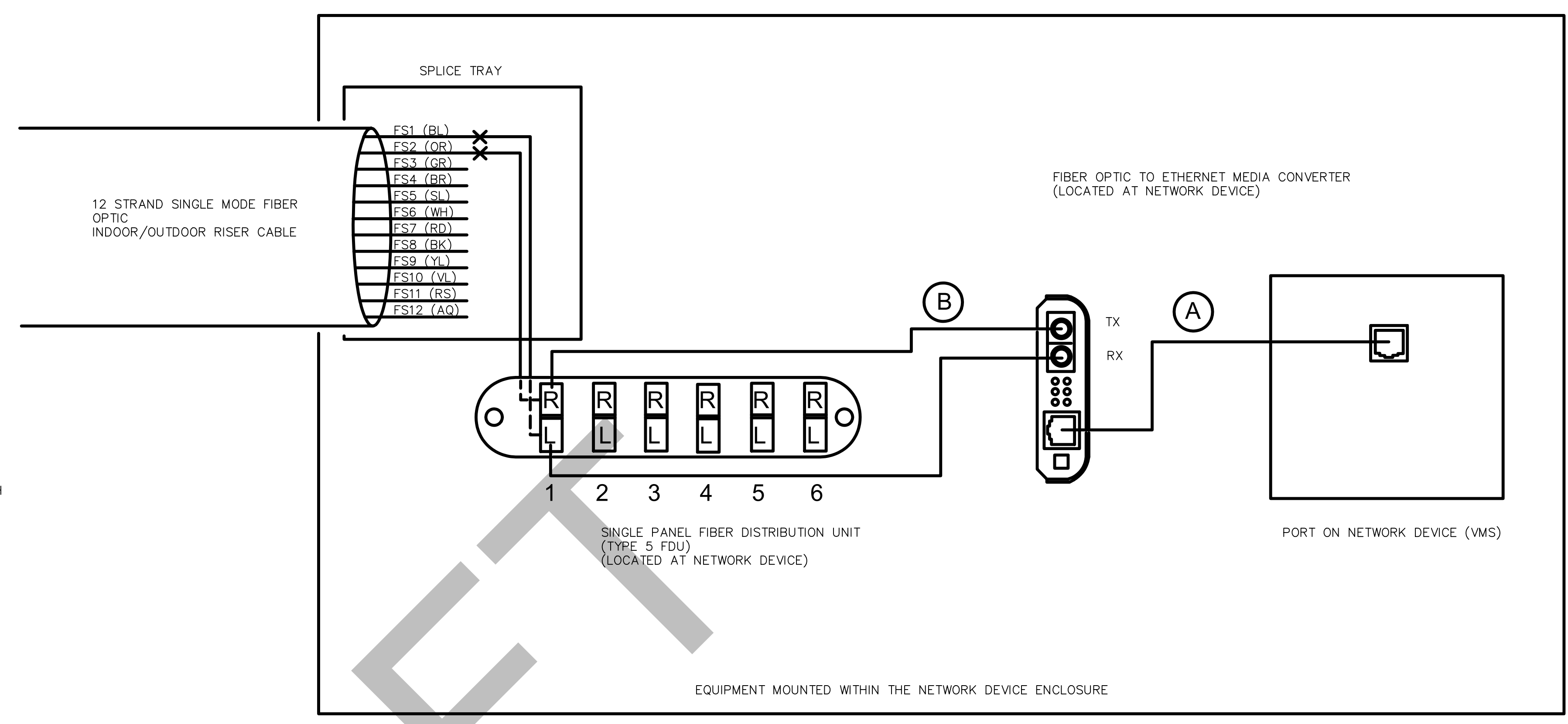

TYPICAL NETWORK DEVICE (VMS) CONNECTION VIA SINGLE MODE FIBER OPTIC CABLE

NOT TO SCALE

EXISTING SPLICE VAULT  
AT SOUTHWEST CORNER OF SEACOAST DR AND ELDER

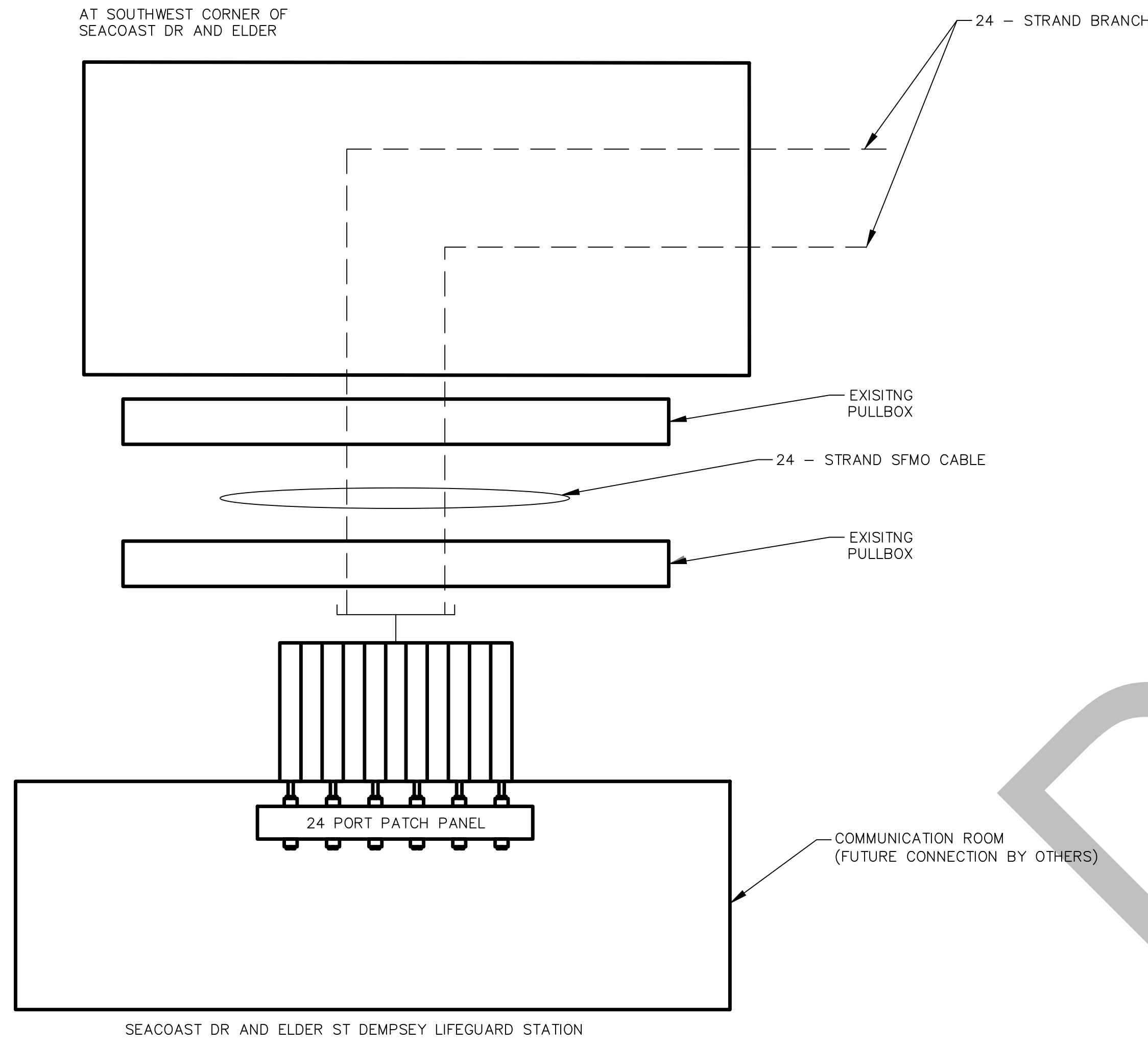

DETAIL B

NOT TO SCALE

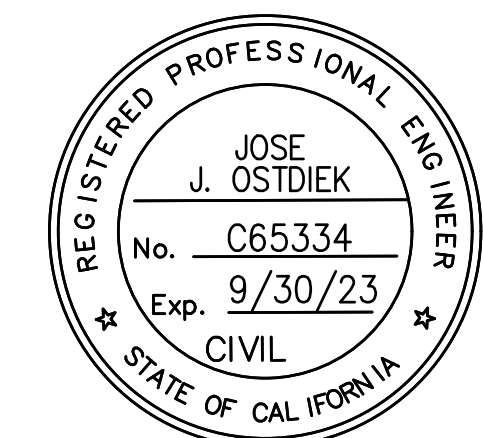

*Jose J. Ostdiek*  
JOSE J. OSTDIEK R.C.E. NO. 65334 EXP. 09-30-23

DOKKEN ENGINEERING  
1450 FRAZEE ROAD, SUITE 100  
(858) 514-8377

10/31/2023  
DATE

PRIVATE CONTRACT

FIBER OPTIC CABLE SYSTEMS FOR  
**IRIS RAPID CORRIDOR AND STATION DESIGN**  
IMPERIAL BEACH BLVD/CORONADO AVE

CITY OF IMPERIAL BEACH, CALIFORNIA		PROJECT NO. 686500
SHEET 69 OF 69 SHEETS		V.T.M.
DESCRIPTION	BY	APPROVED
		DATE
		FILMED
		1786-6299
		NAD83 COORDINATES
		146-1739
		LAMBERT COORDINATES
AS-BUILTS		
CONTRACTOR		DATE STARTED
INSPECTOR		DATE COMPLETED
		<b>42363-69-D</b>

NEW SHEET

ATTACHMENT A1  
CONSULTANT'S PROPOSAL

DRAFT



## Construction Management Services for *Iris Rapid Bus Stops and Transit Center East*



CONSTRUCTION SERVICES

Kleinfelder Construction Services, Inc.

5761 Copley Drive, San Diego, CA 92111

P: 858-223-8500 | F: 858-223-8499

February 13, 2024

Steve Augustyn  
Contract Officer  
San Diego Metropolitan Transit System  
1255 Imperial Avenue  
San Diego, CA 92101

**RE: Proposal for Iris Rapid Bus Stops and Transit Center East Construction Management Services**

Mr. Augustyn:

Kleinfelder Construction Services, Inc. (KCS) appreciates the opportunity to present our proposal to San Diego Metropolitan Transit System (MTS) for the above referenced project. We have carefully reviewed the bid documents and offer MTS a team with the expertise, depth of experience, and resources required to serve on this task order. We are proud of our successful history working with MTS and look forward to continuing our relationship by serving on this important project.

We are happy to propose an exceptionally qualified, local team with in-depth knowledge gained through our diverse experience on MTS and SANDAG projects and an unparalleled record providing management and inspection on similar contracts. This experience includes projects such as the South Bay Bus Rapid Transit Phases 1A, 1B, and 2A/B, the Mid-City Rapid, South Bay and East County Bus Maintenance Facilities, Green Line Station Platform Modifications, Downtown Stations Platform Modifications, Blue Line Station Rehabilitation and Rail Replacement, Orange Line Stations Modifications, and the Orange Line Courthouse Station projects to name a few. We are familiar with MTS' standards and procedures as well as local regulations, infrastructure, and transportation improvement plans. This insight means the KCS team will be able to start work immediately with no learning curve—benefiting MTS by providing valuable time and cost savings.

Our experienced and accomplished staff members are available and ready to serve on this contract. They bring extensive experience providing services on local rapid bus and transit center/station projects with scopes of work similar to those anticipated for this project, including bus shelters, variable message signs, bus pads, and communications and electrical upgrades. With the experience and lessons learned from our previous work on similar transit projects, coupled with our team's expansive research and preparation, KCS will be able to provide an efficient approach to the Iris Rapid Bus Stops and Transit Center East project. Both KCS and our subconsultant team members have committed our resources and are eager to start work on this exciting project.

We want to serve MTS! We believe there is no better group of local individuals who will seamlessly work with MTS to provide high quality, professional construction management and inspection than the KCS team. We appreciate the opportunity to be of service and look forward to hearing from you. If you have any questions or need any additional information, please contact me any time.

Sincerely,

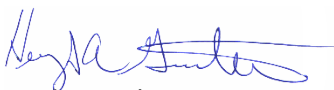

Hank Gentile, PE  
Project Manager  
M: 858-705-0076  
E: hgentile@kleinfelder.com



## 1. PROJECT TEAM

Based on our experience and understanding of Metropolitan Transit System’s (MTS) needs for this project, we have assembled a strong local team of skilled engineers, inspectors, and technical experts with extensive experience in transit construction and experience working on MTS projects. Our local team is currently completing construction management and inspection services on two MTS projects, MTS’ Bayside Double Track IMT project and MTS’ El Cajon Third Track project. We also recently provided services on the award-winning MTS Orange Line Courthouse Station, Trolley Improvement Program, Blue Line Station Rehabilitation and Rail Replacement, Green Line Station Platform Modifications, Orange Line Station Platform Modifications, and Downtown Stations Platform Modifications.

Our goal in staffing the Iris Rapid Bus Stops and Transit Center East project is to provide MTS with exceptional team members that you know and trust, who possess direct experience in managing and inspecting construction projects, and who understand the importance of maintaining safety and minimizing impacts to the traveling public. Our team members are ready, available, and excited to begin working on the Iris Rapid Bus Stops and Transit Center East project.

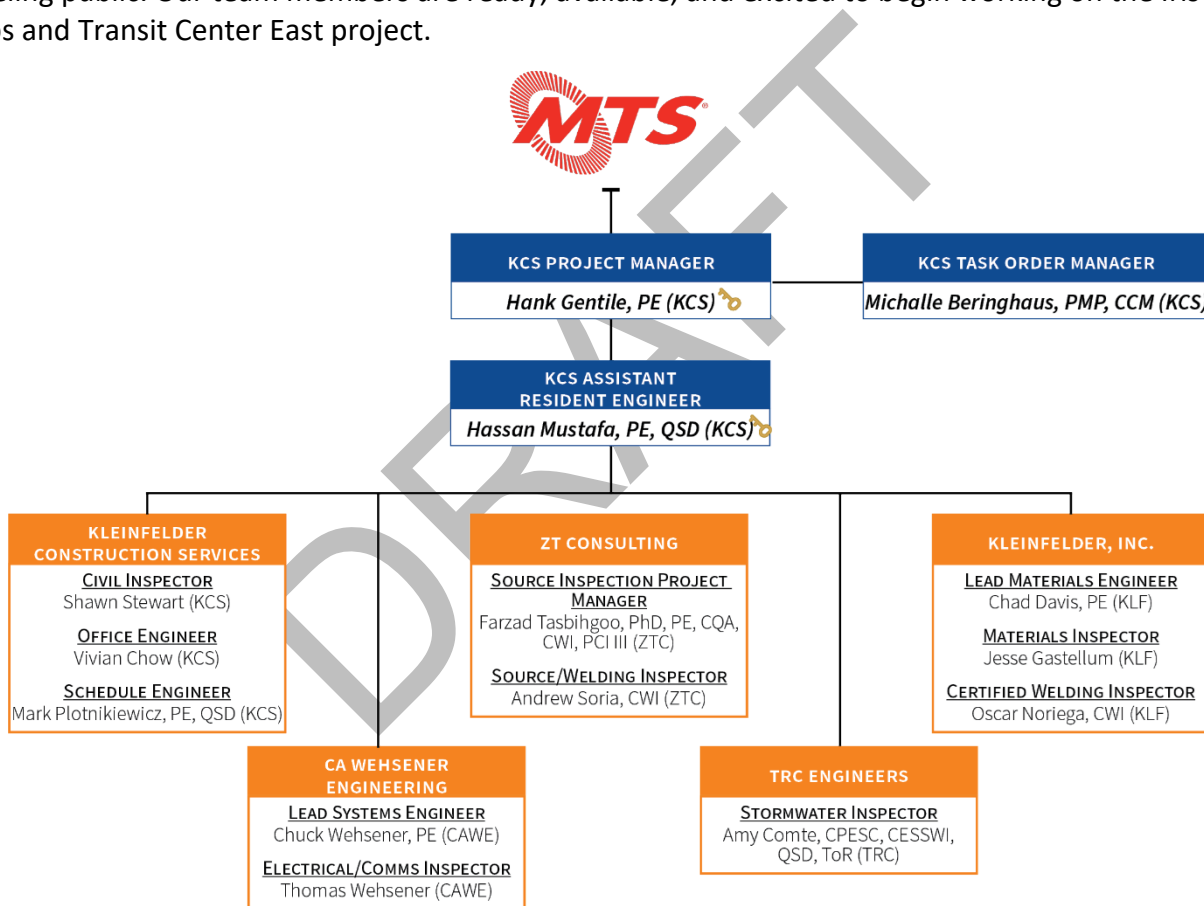

## TEAM INTRODUCTION

KCS along with our subconsultant teaming partners, CA Wehsener Engineering (CAWE), ZT Consulting (ZTC) Kleinfelder (KLF), and TRC Engineers (TRC) have worked on numerous projects together and have substantial experience providing services on MTS projects. Additionally, our team is experienced in working with the City of San Diego and the City of Imperial Beach and will utilize our relationships to help make this a successful project.

The following table provides a brief introduction to each of our proposed staff members' qualifications and relevant experience. *Full resumes for all of our team members have been included in Exhibit A of this proposal.*



Name	Yrs of Exp	Yrs w/ Firm	Education and Certifications	Relevant Project Experience
<b>Hank Gentile, PE</b> Project Manager (KCS)	35	27	B.S., Civil Engineering Civil Engineer in California, No. 57280	MTS East County Bus Maintenance Facility SANDAG South Bay Bus Maintenance Facility Demolition
<b>Michalle Beringhaus, CCM, PMP</b> Task Order Manager (KCS)	23	12	B.S., Landscape Architecture Certified Project Management Professional (PMP), No. 2931105 CMAA Certified Construction Manager (CCM), No. 29230	City of Chula Vista On-Call Caltrans District 11 On-Call SANDAG On-Call City of San Diego West Mission Bay Drive Bridge Replacement
<b>Hassan Mustafa, PE, QSD</b> Assistant Resident Engineer (KCS)	32	11	B.S., Civil Engineering Civil Engineer in California, No. 53489 Qualified SWPPP Developer in California, No. C53489 (SMARTS)	MTS El Cajon Third Track MTS Bayside Double Track IMT MTS Orange Line Courthouse Station City of Chula Vista Major Pavement Rehabilitation FY 18/19
<b>Shawn Stewart</b> Civil Inspector (KCS)	30	15	High School Diploma CAL/OSHA 10-Hour Construction Safety and Health Training	SANDAG South Bay Bus Rapid Transit Segment 1B SANDAG Blue Line Station Rehabilitation and Rail Replacement
<b>Vivian Chow</b> Office Engineer (KCS)	5	1	B.S., Engineering Management	MTS El Cajon Third Track SANDAG Mid-Coast Corridor Transit Project
<b>Mark Plotnikiewicz, PE, QSD</b> Schedule Engineer (KCS)	33	27	B.S., Civil Engineering Civil Engineer in California, No. 58609 Qualified SWPPP Developer in California, No. 20057	MTS El Cajon Third Track MTS Bayside Double Track IMT MTS Orange Line Courthouse Station
<b>Chuck Wehsener, PE</b> Lead Systems Engineer (CAWE)	34	15	B.S., Electrical Engineering Electrical Engineer in California, No. 14977	MTS El Cajon Third Track MTS Bayside Double Track IMT MTS Orange Line Courthouse Station
<b>Thomas Wehsener</b> Electrical/Comms Inspector (CAWE)	37	15	Electrical Union Apprentice Program	MTS El Cajon Third Track MTS Bayside Double Track IMT MTS Orange Line Courthouse Station
<b>Farzad Tasbihgoo, PhD, PE, CQA, CWI, PCI III</b> Source Inspection Project Manager (ZTC)	21	9	PhD, Civil Engineering M.S., Structural Engineering B.S., Civil Engineering Civil Engineer in California, No. 71403 AWS Certified Welding Inspector (CWI), No. 11081291 ACI Concrete Field Testing Technician – Grade I, No. 1226819 ASQ Certified Quality Auditor (CQA), No. 67819	LACMTA (Metro) Soundwall Package 11 RCTC I-15 Railroad Canyon Interchange City of Los Angeles North Atwater Non-Motorized Multimodal Bridge RCTD I-15 & Limonite Interchange
<b>Andrew Soria, CWI</b> Source/Welding Inspector (ZTC)	17	5	ACI Concrete Field Testing Technician – Grade I, No. 1260809 ACI Concrete Strength Testing Technician, No. 1260809 AWS Certified Welding Inspector (CWI), No. 20022691 PCI Level III, No. 14594	SBCTA SR-210 & Base Line Road LA Metro Sound Wall Package No. 11 SANDAG Mid-Coast Corridor Transit Project City of Orange Public Works OSO Parkway SBCTA Monte Vista Grade Separation
<b>Chad Davis, PE</b> Lead Materials Engineer (KLF)	29	6	M.S., Business Administration B.S., Civil Engineering Civil Engineer in California, No. 59908	SANDAG MidCoast Trolley Line Caltrans D11 Materials Sampling and Testing Services City of San Diego As-Needed Geotechnical and Materials Testing



<b>Jesse Gastelum</b> Field Materials Tester (KLF)	27	9	High School Diploma ACI Concrete Field Testing Technician, Grade I	Caltrans D11, Construction Materials Sampling and Testing County of San Diego, On-Call Geotechnical Engineering Testing
<b>Oscar Noriega, CWI</b> Certified Welding Inspector (KLF)	25	4	High School Diploma ACI Concrete Field Testing Technician, Grade I American Welding Society Certified Welding Inspector City of San Diego Special Inspector	County of San Diego, Courthouse Commons Tunnel and Transfer Shaft City of San Diego, West Mission Bay Drive Bridge
<b>Amy Comte, CPESC, CESSWI, QSD/P, ToR</b> Stormwater Inspector (TRC)	19	8	B.A., Geography Construction General Permit ToR Caltrans Water Pollution Control Manager Course NPDES Basic Training Caltrans 24 Hour Course Construction Water Pollution Control Course	SANDAG South Bay Bus Rapid Transit Segment 1A/1B, Segment 2 and Segment 3 SANDAG Pershing Drive Bikeway and Roadway Improvements Project SANDAG, Program Management of Stormwater Compliance and Construction Management Services

We are proud to provide MTS with staff who you know and trust, who possess direct experience in managing and inspecting construction projects, bring the required technical skills, and understand the importance of maintaining safety while minimizing impacts to the traveling public. Together, our team will perform as part of an integrated team with MTS, providing cost effective and functional solutions for a successful project delivered on time and on budget.



## 2. PROJECT UNDERSTANDING AND APPROACH

### UNDERSTANDING

The MTS Iris Rapid Bus Stops and Transit Center East project will upgrade the 11 Rapid bus stops in the cities of San Diego and Imperial Beach. These upgrades include new bus shelters, Variable Message Signs, bus pads and sidewalks.

Location	Small Shelter	Large Shelter	VMS Sign	New AC Bus Pad	New Conc Bus Pad	Exist. Bus Pad Imp.	Stamped Colored Conc SW	Conc SW	Gravity Wall	City of IB	City of SD
Dahlia Ave and SB Seacoast Drive		X	X	X						X	
Imperial Beach Pier and SB Seacoast Drive		X	X	X						X	
EB Imperial Beach Blvd and 3rd Street			X							X	
<del>3rd Street and WB Imperial Beach Blvd.</del>	X		X	X		X				X	
EB Imperial Beach Blvd. at SD County Sheriff Station	X		X	X			X	X		X	
<del>WB Imperial Beach Blvd. at Veteran's Park</del>	X		X	X		X		X		X	
EB Imperial Beach Blvd. near Georgia Street	X		X	X		X		X		X	
<del>WB Imperial Beach Blvd near 13th Street</del>	X		X	X		X					
WB Coronado Ave near Saturn Blvd	X		X		X			X	X		X
EB Coronado Ave near Hollister St	X		X		X			X			X
WB Coronado Ave near Hollister St	X		X					X			X

Additionally, select areas of the Iris Transit Center East will be upgraded. This work includes new concrete bus pads, new concrete walkways, and an upgraded electrical and communications system. The project also includes traffic signal and signing/stripping improvements at Coronado Avenue and 30<sup>th</sup> Street and a new ADA curb ramp at Coronado Avenue and Beyer Boulevard. The project was recently advertised for construction and the low bid was \$5.5M.



## APPROACH

The following outlines the steps our team will take to address and complete the required services for this project:

- Meet with the MTS Project Manager to review key points of the construction contract and discuss key issues.
- Review the contract documents and gain a thorough understanding of the work involved.
- Take preconstruction photos at each work location, documenting existing conditions and the locations of the pertinent equipment.
- Verify the specific requirements in the encroachment permits from the City of San Diego and the City of Imperial Beach.
- Utilize as-builts from the previous construction contracts to review and refresh our understanding of the existing facilities.
- Coordinate with MTS regarding a preconstruction meeting and provide any assistance MTS needs or lead at MTS' request.
- Coordinate with the MTS Public Information Officer to keep the adjacent businesses aware of the potential construction impacts.
- Confirm material procurement on long lead items are submitted early to minimize potential delays.
- Complete potholing as a first item of work to verify any potential utility conflicts.
- Work with the contractor to verify the existing utility conduits have sufficient space for the new cables and that the conduits are intact.
- Coordinate with MTS regarding bus stop closures and transit center impacts.
- Verify if MTS parking lots may be used as potential staging areas.
- Confirm the contractor's materials storage and housekeeping methods leave the staging areas secured and safe at the end of their shift.
- Confirm the Contractor has the necessary traffic control to facilitate their activities; approved materials are being installed per the plans; disruptions are minimized at the bus stops; demolition work is contained to the areas shown on the plans; existing communications system remains functional; and coordinate with MTS Operations, Systems, and IT, as necessary.
- Verify pedestrian detours are in place per the approved traffic control plans and the detours are ADA compliant.
- Coordinate with the Contractor and MTS Systems personnel to get the communications infrastructure installed in the most efficient and least invasive or damaging way possible.
- Coordinate with the Contractor and MTS for owner supplied materials including the Ameron concrete poles, luminaires, and pole arms for the Pier Plaza lighting and the traffic signal poles for the Coronado Avenue and 30<sup>th</sup> Street intersection.
- Prepare and file daily diaries that are accurate in documenting the weather, location of work, notable issues or discussions that take place, location and quantity of installed work, and verify that the Contractor adheres to the safety requirements of the contract.
- Track and document work performed and installed which facilitates ease of development and/or verification of the Contractor's monthly progress payments.



- Confirm that the Contractor rehabilitates the work areas to their prior condition after any saw cutting, trenching, conduit installation, and backfilling. The listed work locations include a variety of paving finishes, including reinforced concrete with sawcut patterns, colored concrete, stamped concrete, brick, and ADA compliant installations.
- Assist the MTS Project Manager in any of the Construction Management/Contract Administration tasks necessary, including submittal and RFI review and responses, progress payments, correspondence to the contractor, notices of non-conformance or requirements for corrective action, addressing safety issues, and contract completion and closeout.
- Document the work and verify there are accurate and proper as-builts recorded of the work and whether the Contractor is required to provide as-builts per the construction contract, which is typical.

### Storm Water Permit Compliance

Our Resident Engineer and Inspectors are experienced in reviewing and approving Water Pollution Control Plan (WPCP)/Storm Water Pollution Prevention Plans (SWPPP) and performing routine weekly inspections as well as pre/post Qualifying Precipitation Event (QPE) inspections. Prior to construction our team will perform a comprehensive review of the Contractor's stormwater plan for compliance with State Water Resource Control Board (SWRCB) Construction General Permit (CGP) Order No. 2022-0057-DWQ requirements, or - if soil disturbance is determined to be less than one acre the plan will be reviewed to ensure compliance with the city Storm Water Manual. Our staff can assist MTS with evaluating the permitting options and potentially minimize compliance exposure if determined to be less than one acre of disturbance.

If the project is covered by the CGP, as a data submitter we will complete the Notice of Intent that will include the project registration documents in the Storm Water Multiple Application and Report Tracking System (SMARTS) and through the life of the project maintain SMARTS that will include completing Changes of Information (COI), annual reporting ad-hoc sampling reports and Notice of Termination (NOT).

During construction, our staff will verify compliance with the approved SWPPP or WPCP and work closely with the Contractor to ensure that Best Management Practices (BMPs) are correctly implemented and maintained according to risk level. We will also ensure that the contractor completes all required inspections and any required sampling and analysis, including TMDLs. Our team recognizes that proactive coordination with the Contractor will decrease the pollution in run off to the Maximum Extent Practical (MEP) and the potential for storm water related violations.

### MTS Experience and Knowledge

While we feel that our approach to project issues and challenges will be a key factor in delivering this project successfully, it is our MTS experience combined with our construction management know-how that is at the core of this unmatched team. The key members of this team, including KCS Project Manager Hank Gentile, KCS Resident Engineer Hassan Mustafa, and our subconsultant CAW Engineering, have all served in leadership roles in the Construction Management of major MTS projects. Plus, we have managed major bus infrastructure improvement projects, including the MTS East County Bus Maintenance Facility. Our projects include the *Blue Line Crossover and Signaling Project, Trolley Improvement and Low Floor Program's Blue Line, Green Line, Orange Line and Downtown Station Improvement Projects, Mission Valley East & West, and most recently the MidCoast Trolley Extension*, which was successfully brought online in November of 2021 – on time and within budget. Our team is also currently working on both the *IMT Double Track and El Cajon Third Track Projects, and also completed the new Courthouse Station*. This team has also participated in numerous other MTS projects, including the *SDSU Station air handling and fire suppression infrastructure and the Track Upgrades on C St. between 2<sup>nd</sup> and 3<sup>rd</sup> Avenues*.



## CHALLENGES/RISKS

While the RFP requests that we identify two risks and propose solutions, we have chosen to include three risks/solutions, as follows:

### Material and Equipment Procurement Times

Based on our experience from similar projects and our understanding of current industry trends, we know that bus shelters and traffic signal poles are long-lead materials and should be submitted and ordered as early in the project as possible to minimize the potential for delays. Additionally, the VMS poles are a potential long-lead item due to fabrication requirements. We understand that the traffic signal poles are listed as an MTS furnished item and may not require a submittal by the contractor. However, the signal foundation locations will need to be verified and may result in the need for a submittal.



One of the first orders of work should be potholing for the traffic signal foundations at the intersection of Coronado Avenue and 30<sup>th</sup> Street to verify if there are any utility conflicts. If conflicts are encountered and the utilities cannot be relocated, the proposed signal foundations may need to be moved and may result in revisions to the proposed pole sizes and mast arm lengths. Since these poles and mast arms are MTS furnished items, it is crucial to determine the actual locations for the traffic signal foundations as early as possible to confirm the sizes for the poles and mast arms. If the pole sizes need to be revised due to the new foundation locations, performing this step early in the project will help minimize potential delays and allow the contractor to begin the submittal and procurement process quickly.

On previous projects, we have used a Limited Notice to Proceed (LNTP) to allow a contractor to begin the submittal process and perform potholing without impacting contract time. The LNTP is issued ahead of the Notice to Proceed (NTP) and has specific requirements in the specifications on what activities can be performed as well as the length of the LNTP period. This is an excellent tool to help mitigate potential delays due to long-lead material procurement and allows the contractor extra time to manage to prepare quality submittal packages.

During the preconstruction meeting, we will discuss these long-lead materials with the Contractor and verify that these submittals are their first priority. Our team will expedite the review of the long-lead materials submittals in order to begin the fabrication and procurement process as soon as possible. Additionally, we will direct that our Source Inspection subconsultant, ZTC, prioritize the inspections of the long-lead materials as to not delay the procurement process.

### Existing Utilities/Existing Conduits

Several of the proposed construction activities have the potential to be impacted by existing utility conflicts. These include bus shelter footings, VMS foundations, traffic signal foundations, bus pads, conduit trenching, and horizontal directional boring. One of the contractor's first items of work will be potholing the existing utilities. If utility conflicts are found, we will work with the third-party utilities and the designer to come up with a plan which could include relocating the utility, relocating the proposed work, or incorporating the utility into the work. We have developed excellent relationships with the City of San Diego, City of Imperial Beach and local third-party utilities including SDG&E, AT&T, Cox, Crown Castle, Verizon, MCI, California American

Water, and many others. We will use these relationships to coordinate solutions to utility conflicts, establish schedules for any required relocations, and assist with coordinating the contractor's work.

Several existing conduits are planned to be utilized for the proposed work. These sizes of the existing conduits will need to be verified to determine if the proposed cables will fit. Additionally, the condition of the conduit runs will need to be verified. Any broken conduit or conduits with sub-standard radii may not be useable and new conduits may need to be installed.

### Temporary Pedestrian Facilities

The work at the bus stop locations may require pedestrian detours. These pedestrian detours will need to be included in the contractor's traffic control plans. All pedestrian detours will require the proper signage and must be ADA compliant. Our team has extensive experience in reviewing and inspecting temporary pedestrian facilities. We will use the Manual on Uniform Traffic Control Devices (MUTCD) and the Caltrans Temporary Pedestrian Access Routes (TPAR) Handbook as guidelines for our reviews and inspections to verify the proper signage is used, minimum widths and maximum slopes are maintained, and a continuous pathway for travel is maintained. We will document our inspections and confirm any deficiencies are corrected immediately.



### 3. SCHEDULE

KCS has proposed a CM team with broad experience in delivering transit improvement projects for MTS, SANDAG, and other regional transportation agencies. Our team possesses expertise in all project work disciplines, including civil, structural, and specialty systems. Backed by our record over the last 15 years of successfully delivering the largest and most challenging projects on the MTS system, our team's knowledge and experience with the MTS system is unparalleled. We understand both the process and the documentation necessary to work with MTS in successfully negotiating a Work Order and can meet the demands of the contracting and procurement schedule for the project. Our system is geared toward servicing as-needed/on-call construction services contracts, with a Project Controls group dedicated to developing and servicing Work Orders, including the necessary monthly reports and accurate invoices.

Furthermore, the KCS team has the depth of available resources to respond to the demands of fast paced construction projects, work at multiple locations simultaneously, and support MTS should unforeseen needs arise. Once we receive the Notice to Proceed, we will get to work immediately in coordinating with both MTS and the Contractor to provide the necessary level of staffing support and service MTS needs to deliver a successful contract.

Kleinfelder is headquartered in San Diego, and our Construction Services (KCS) office and Materials Laboratory is located in Kearny Mesa. Our staff are local and are committed to serving MTS. CAW Engineering, also locally headquartered, knows the MTS system thoroughly and works regularly with KCS on MTS projects. ZTC has a long history working with KCS and have dedicated staff to serve on this project. They have team members throughout the country that can serve as "local" resources for the project's source inspection needs.

The Iris Rapid Bus Stops and Transit Center East project had a low bid of \$5.5M dollars and has a duration of 245 calendar days with work beginning around May 2024. The work is at multiple locations throughout the City of San Diego and the City of Imperial Beach. We anticipate the contractor will be working at multiple bus stop locations concurrently along with the improvements at the Iris Transit Center. The early work will include the electrical/communication underground work while the shelters and VMS signs are being fabricated. Next, we anticipate the foundations for the VMS signs and bus shelters to be completed, followed by the site work and bus pads. Finally, the VMS and bus shelters will be installed along with the remaining appurtenances.

At the beginning of the construction contract, our CM team will review and work towards approving the contractor's



Baseline Schedule. This schedule establishes the contractor's intent on constructing the project and is an important document in our team's efforts in managing the construction schedule. We utilize the Baseline Schedule, in conjunction with three week look-ahead schedules and the contractor's monthly schedule updates, to:

- Manage and track project deliverables, submittals, RFIs, and change orders
- Assess construction progress and potential delays
- Identify potential work around scenarios to maintain schedule.

We will review the three-week look-ahead schedules to ensure it corresponds with the latest Monthly CPM Update and use it to verify actual dates shown in the update schedules. Prior to submitting the Monthly CPM Updates, we will meet with the Contractor to discuss the progress of the schedule activities and any proposed schedule revisions. All revisions will need to be approved prior to being incorporated into the monthly update. The monthly updates will be reviewed to ensure the actual dates are correct, only approved schedule revisions have been incorporated, and the Contractor is following their proposed work plan.

All time extensions requested by the Contractor must include a Time Impact Analysis (TIA). We will review each TIA submitted by the Contractor and prepare an independent TIA if necessary. The TIA report will include details regarding the time impact including a synopsis of the delay, timeline of impacted events, the unimpacted and impacted schedules used to create the TIA, changes made to the unimpacted schedule to create the impacted schedule, and recommended time adjustment. Any approved contract time adjustments will be included in a contract change order.

All schedule submissions will be reviewed and responded to in writing, in detail, and in a timely manner. A Schedule Submission Tracking Log will be used to track the submittal and review times of the schedules to ensure our review times comply with the requirements of the contract documents. If the Contractor fails to submit schedules within the time frames specified in the contract documents, payment to the Contractor may be withheld.

#### 4. SUBCONSULTANTS

We have carefully assembled our team with an understanding of the project needs and MTS requirements. We have a long working history with our subconsultants and are proud of our relationships and teamwork we have developed. The follow are the subconsultants on our team and a brief description of their role:



KCS' parent company, **Kleinfelder, Inc. (KLF)**, will provide materials sampling, testing, and field certified welding inspection. Kleinfelder has served San Diego's local agencies for more than 50 years. Headquartered in San Diego with a large staff of Environmental Specialists, Source Inspectors, Materials Testers, Plant Inspectors, Geotechnical Engineers, and a Caltrans-certified laboratory, Kleinfelder's local presence and experience with MTS and other local agencies provides the advantage of working with experienced and available professionals who understand the local environment, while also being able to draw upon the extensive resources of the entire firm. While Kleinfelder is technically listed as a subconsultant team member, MTS will enjoy the benefits and efficiencies realized by working with a singularly managed team.



**CA Wehsener Engineering, Inc. (CAWE)** was founded by Charles Wehsener in 2007 to provide electrical construction management, inspection, and engineering services. CAWE is a local San Diego small business firm with expert staff members and over 40 years of experience. CAWE's staff not only have years of experience inspecting electrical construction work, but all have worked as electricians performing the actual work, which provides them with a greater knowledge and understanding of the work they are inspecting. They are recently provided electrical and systems construction management and inspection on the high p





profile, SANDAG Mid-Coast Corridor Transit Project.



**ZT Consulting Group, Inc. (ZTC)** is a certified small business specializing in quality assurance and source inspection, forensic engineering, and structural health monitoring for public transportation projects. ZTC's team brings decades of experience in design, construction, and fabrication support services in California, including direct experience working with Caltrans Materials Engineering and Testing Services and Caltrans Office of Structural Materials (OSM) where they assisted OSM in developing and implementing a quality assurance program for source inspection. This experience provides ZTC with an exceptional working knowledge of Caltrans Source Inspection Guidelines for Local Agencies, Caltrans Specifications, OSM Practices and Procedures Manual, and FHWA Title 23 requirements.



**TRC Engineers, Inc. (TRC)** is a construction management firm with offices throughout Southern California, including San Diego, Encinitas, and Carlsbad. For more than 50 years, TRC has provided clients with construction management expertise to address complex engineering issues and challenges on a wide variety of projects. For this project, TRC will provide Stormwater Inspection services. TRC's engineers are experts in providing water quality monitoring, inspection, plan preparation and review, and NPDES inspections, as well as leading NPDES training sessions. Their experience includes having provided services to SANDAG for their Program Management of Stormwater Compliance and Construction Management Services contract, as well as numerous local transit and roadway projects.

DRAFT

# EXHIBIT A

## STAFF RESUMES



## Hank Gentile, PE (KCS)

### Project Manager

## EDUCATION/PROFESSIONAL CREDENTIALS

B.S., Civil Engineering  
Civil Engineer in California, No. 57280

Hank Gentile will serve as KCS' Project Manager and will be responsible for coordinating overall project activities and performance. He has managed several on-call construction management and inspection contracts and has had direct involvement on MTS projects, including serving as Project Manager for the Orange Line Courthouse Station project and Resident Engineer for the Orange Line Stations Platform Modification, Green Line Stations Platform Modification, East County Bus Maintenance Facility, and South Bay Bus Maintenance Facility. His management style is responsive, hands-on, personal, and detail oriented. Hank knows the kind of person and skill set it takes to successfully perform inspection and management duties for all types of projects, and he will ensure MTS gets the right person for each assignment.

### **MTS On-call Construction Management, Various Projects**

Mr. Gentile has served as Project Manager for KCS' two concurrent prime as-needed construction management contracts, included our current contract. Through these contracts, KCS has worked on several task orders, including the Blue Line Traction Power Substation Installation and current Bayside Double Track IMT and El Cajon Third Track projects. As Project Manager, Mr. Gentile is responsible for implementing and managing all task orders, as well as assembling and overseeing KCS and subconsultant staff providing construction management, inspection, constructability review, document controls, and scheduling services to MTS on simultaneous projects. In addition, he provides quality control, staff management, and technical oversight.

### **MTS On-call Construction Management, Orange Line Courthouse Station**

Mr. Gentile served as KCS' Project Manager for the \$6.8M Orange Line Courthouse Station project in San Diego, California. The project included construction of a new trolley station in downtown San Diego on C Street between Columbia Street and 1st Avenue, and the relocation of the Orange Line terminus from the Santa Fe Depot to the new station. The new station provides direct access to the new 22-story courthouse building, helps to relieve congestion at the Santa Fe Depot station, and improves overall service to the Downtown area. As Project Manager, Mr. Gentile was responsible for providing oversight to the construction management team, implementing and executing our team's quality control procedures, verifying team members were adequately equipped and trained to perform their job function, and monitoring our performance on a frequent basis with MTS.

### **SANDAG On-call Construction Management Services, Low-Floor Stations Downtown**

Mr. Gentile serviced as Principal-in-Charge/Constructability Reviewer for SANDAG's Low-Floor Stations Downtown (LFSDT) project. LFSDT was part of the SANDAG/MTS \$660M Trolley Renewal Project, an endeavor to rebuild aging trolley infrastructure on the Blue, Orange, and Green lines that included upgrading track, signaling, and communications, and modifying platforms at 35 stations to support the deployment of 65 new low-floor trolley vehicles. The LFSDT project includes a suite of improvements to meet low floor program objectives at five signature trolley stops throughout the heart of downtown San Diego's East Village, Gaslamp, and Civic Core neighborhoods where existing stations were reconstructed to accommodate the new low-floor trolley vehicles. Project elements included demolition and reconstruction of five trolley stations; station paving; platform shelter structures; site furnishings and signage; lighting; landscaping; traffic signal modification; and signal, communications, and electrical infrastructure. Accessibility improvements were a primary feature of the LFSDT project. Platform crossfall, slope, new code compliant curb ramps, seating, and signage were all incorporated into the platform improvements. Aesthetic improvements included steel fabricated shelters to minimize view blockage and to provide maximum shelter from the elements, and also included built-in seating. Each station was constructed with new precast architectural pavers, Lithocrete architectural concrete, and architectural barrier railings. The 12th and Imperial Transfer Station included the installation of two new 115 RE No. 6 turnouts and 150 feet of new track work.

### **SANDAG On-call Construction Management Services, Green Line Station Platform Modifications**

Mr. Gentile served as the Resident Engineer on the Green Line Station Platform Modifications project. This \$8.5M project consisted of modifications to eight stations that can accommodate the new low floor vehicles. The original Green Line Contractor was unable to perform. Mr. Gentile worked with SANDAG to reduce the contract scope to two stations, which were completed by subcontractors at Mr. Gentile's direction. He managed the construction of the remaining six stations through three separate JOCs. Mr. Gentile coordinated with active MTS trolley lines as well as NCTD operations and had the overall responsibility for quality assurance inspection, administration, and lead a team of field engineers, office engineers, and administrative support staff to complete this project. Mr. Gentile also participated in the constructability reviews by providing comments on the plans and specifications and identifying potential claims before they arise during construction.

### **SANDAG On-call Construction Management Services, Orange Line Stations Modifications, Downtown**

Mr. Gentile served as the Resident Engineer for the Orange Line Station Modifications project, responsible for issue resolution, project completion, and closeout. As part of the Trolley Renewal project, the Orange Line Modifications included replacing older

vehicles with new low-floor vehicles and the raising of platforms to accommodate faster and level boarding. Station improvements included larger shelters with new furnishings, digital next arrival signs, and upgrades to the track and train signaling system. At SANDAG's request, Mr. Gentile took over as Resident Engineer for the project and negotiated many outstanding change orders with the Contractor, bringing the job to completion. These projects were all constructed under active trolley operations and required constant coordination with MTS and NCTD. Mr. Gentile's responsibilities included leading a team of field engineers/inspectors, office engineers, and administrative support staff, and contract administration.

#### **SANDAG On-call Construction Management Services, MTS East County Bus Maintenance Facility**

Mr. Gentile served as the Resident Engineer for SANDAG's \$45M East County Bus Maintenance Facility (ECBMF) project in El Cajon, California. This expansion and renovation project included a new 34,500-square-foot steel moment-frame high-bay maintenance building, a new state-of-the-art compressed natural gas (CNG) fueling station, a new 10,275-square-foot administrative building, and reconfiguration of staff and bus parking. The project required significant interface and communication with MTS management and staff, the City of El Cajon, as well as utility coordination efforts. The project was constructed in phases to maintain existing bus operations, fueling, and bus and employee parking. Extensive coordination with MTS was required upon completion of the new structure to transfer and resume operations in the new facility. Once completed, the old facility was demolished, and the site paved to accommodate additional bus parking. Prior to construction, Mr. Gentile participated in a multi-disciplinary constructability review, which included working with project designers to resolve comments developed during the review. During construction, Mr. Gentile was responsible for project management, contract administration – including negotiating change orders and resolving disputes, construction engineering, and project communication and coordination. The result was a successful project closeout with no claims or unresolved issues, and a completed facility that is major upgrade for the bus operations and maintenance personnel.

#### **SANDAG On-call Construction Management Services, South Bay Bus Maintenance Facility Demolition and Various Projects**

Mr. Gentile served as Lead Senior Engineer for the \$5M demolition and site preparation project at the MTS South Bay Bus Maintenance Facility. The project consisted of expanding the MTS bus maintenance facility grounds located on Main Street in Chula Vista, and included the demolition and removal of seven building structures and two masonry block retaining walls. The building removals were necessary to accommodate a proposed parking lot which included 222 parking stalls, 57 bus parking stalls, and the future construction of a 50,400-square-foot bus maintenance building. Mr. Gentile served as Resident Engineer during the demolition phase, and performed a pre-construction constructability review, which included 96 detailed comments, a letter report summarizing the major findings, a photo log, and quantity check calculations.

#### **SANDAG On-call Construction Management Services, Mid-Coast Corridor Transit Project**

Mr. Gentile is currently serving as the Structures/Stations Representative for SANDAG overseeing the Construction Management team for the nine trolley Stations being constructed on the Mid-Coast Corridor Project. Work includes the construction of nine new stations; including four at-grade stations—Tecolote Road, Clairemont Drive, Balboa Avenue, and VA Medical Center; and five stations with elevated passenger platforms and at grade plazas—Nobel Drive, Pepper Canyon, Voigt Drive, Executive Drive, and the UTC Transit Center. In addition, Mr. Gentile is assigned a coordination and oversight role for the construction of two multi-level parking structures at the Nobel Drive and UTC Transit Center Stations. His work on this part of the project includes oversight and coordination with the Construction Management/Quality Assurance group, close coordination with the Contractor, change order development and negotiation, and coordination with the Systems group and other disciplines, including the design team.

#### **SANDAG On-call Construction Management Services, Mid-Coast Corridor Transit, Segment 4, Genesee Viaduct**

Mr. Gentile served as Structures Representative for Genesee Viaduct portion of Segment 4 of SANDAG's \$2.1B Mid-Coast Corridor Transit project. With a construction value of \$54M, the 12-frame, 5,700-foot-long Genesee Viaduct incorporated multiple structure types, including the first use of spliced precast bathtub girders in California and two frames of cast-in-place/prestressed concrete box girders (CIP/PS) with extended platform slabs to accommodate passenger loading at stations. The construction process utilized self-weight prestressing, as well as splice and continuity prestressing. Mr. Gentile led the quality assurance efforts for this complex and innovative bridge that was constructed down the middle of Genesee Avenue, a main thoroughfare in one of San Diego's busiest commercial areas. The Mid-Coast project extends Blue Line trolley service north from the Santa Fe Depot in downtown San Diego to the University City community. Segments 3 and 4 includes five stations and is largely comprised of elevated guideway. Additional work includes widening Genesee Avenue from Regents Road to La Jolla Village Drive, barrier installation, road restriping, utility relocations, median and sidewalk demolition, and traffic control.



## Michalle Beringhaus, CCM, PMP (KCS)

### Task Order Manager

Michalle Beringhaus has 23 years of experience as a Senior Project Controls Manager. She performs a variety of assignments requiring the application of project scheduling, cost, and estimating techniques. Her role requires exercising independent judgement in evaluating, selecting, and applying standard scheduling, cost-control and estimating techniques, procedures, and criteria to make minor adaptations and modifications. Ms. Beringhaus assists our Project Managers and Program Managers with the development, organization, and analysis of project data such as fee estimates, earned value analysis, status reports, cost reports, backlog projections, and a multitude of resource needs. She has also been responsible for financial and administrative support in the management of projects including pricing, scope, tracking, and project performance measurement. She excels in developing staffing plans and fee estimates, maintaining program and project schedules for Project Managers, analyzing critical path and constraints to determine the effect of changes to the schedule, providing recommendations for corrective actions, and supporting project teams in all aspects of document management. Ms. Beringhaus performs a variety of additional project tasks, such as permit applications, agency regulation coordination, project funding, community relations, and project correspondence. Her responsibilities also consist of performing contract administration and ensuring contract requirements are upheld in conjunction with all legal teams.

### EDUCATION/PROFESSIONAL CREDENTIALS

B.S., Landscape Architecture  
A.S., Nursing LPN  
CMAA Certified Construction Manager (CCM), No. 29230  
PMI Certified Project Management Professional (PMP), No. 2931105  
ACEC Prevailing Wage Committee Member; Lorman Prevailing Wage Training (2010 Lorman Seminar 385943), AGC; Prevailing Wage Training, LCP Tracker Prevailing Wage; Training, PRISM Prevailing Wage

### **City of Chula Vista On-call Construction Management Services, Various Projects**

Ms. Beringhaus provides Labor Compliance Administration for the City of Chula Vista on numerous projects for this as-needed construction management services contract. Ms. Beringhaus verifies compliance with the City's standards and prevailing wage requirements by reviewing certified payroll records and submitted documentation for these contractors, and coordinates with the Resident Engineer regarding possible violations and discrepancies. KCS is providing construction management and inspection on a variety of capital improvement projects for the City, including street pavement rehabilitation, storm drain, sewer, and sewage pump station construction and rehabilitation; traffic signal modifications; street widenings; ADA curb ramp and sidewalk replacements; as well as signage and striping.

### **City of San Diego West Mission Bay Drive Bridge Replacement**

Ms. Beringhaus provided Task Order Management and Labor Compliance services for this high-profile \$110M City of San Diego bridge replacement project. Two new structures, which span the San Diego River, replace the previous, functionally obsolete structure to increase traffic capacity and provide upgraded bike facilities and pedestrian walkways. The structures feature post-tensioned concrete box girder superstructures, deep pile foundations, and unique architectural features constructed in stages to maintain open lanes of traffic and minimize impacts to the public. Ms. Beringhaus reviewed and submitted certified payroll records, provided prevailing wage monitoring, and coordinated with the Resident Engineer regarding possible violations and discrepancies. Additionally, she managed and tracked the project certified payroll documents utilizing the City's PRISM software.

### **Caltrans District 11 On-call Construction Management Services, Various Projects**

Ms. Beringhaus serves as the Assistant Task Order Manager for this as-needed construction management services contract, worth nearly \$24M covering San Diego County. Her responsibilities include assisting with the development of task orders and cost proposals, development of detailed staffing plans, and costs-to-complete. Ms. Beringhaus coordinates with the subconsultant team members to develop subconsultant agreements and task orders. In addition, Ms. Beringhaus has been instrumental in the development and hands-on use of an in-house customized web-based contract and task order management tool dubbed WoPr, a central interface to house all information related to task orders and contracts. Using this tool, Ms. Beringhaus efficiently prepares and maintains projections, uploads actual invoices, and generates a myriad of reports that are compiled into a monthly report.

### **SANDAG On-call Construction Management Services, Various Projects (Contracts 5001073 and 5007804)**

Ms. Beringhaus serves as a QA/QC I professional and also as the Assistant Task Order Manager for these as-needed construction management services contracts. Contract 5001073 is complete and totaled nearly \$35M worth of work. Contract 5007804 has a not-to-exceed value of \$60M, of which the firm has encumbered \$18M to date. Her responsibilities include assisting with the development of task orders including preparation of cost proposals and developing detailed staffing plans and costs-to-complete. Ms. Beringhaus coordinates with the subconsultant team members to develop subconsultant agreements and task orders. In addition, Ms. Beringhaus has proved instrumental in the development and hands-on use of an in-house customized web-based contract and task order management tool dubbed WoPr, a central interface to house all information related to task orders and contracts. Using this tool, Ms. Beringhaus efficiently prepares and maintains projections, uploads actual invoices, and generates a myriad of reports.



## Hassan Mustafa, PE, QSD (KCS)

### *Assistant Resident Engineer*

Hassan Mustafa has 32 years of experience in the transportation industry, including rail, transit, and highway work for agencies such as Caltrans, MTS, SANDAG, OCTA, and County of San Diego. Hassan is a multifaceted engineer who has a proven track record of completing high-quality projects on time and within budget. Hassan's experience also includes five years as a Project Manager for paving contractor, Pave Tech, during which time he was the sole Project Manager on over \$200M in construction contracts and the single point of contact on over 100 individual construction projects including roadway, runway, taxiway, and parking lot reconstructions. Hassan is well-versed in the allocation and management of staff, contract administration, contract compliance, construction inspection, and problem resolution. His diverse and extensive experience makes him a valuable member of any project team.

### EDUCATION/PROFESSIONAL CREDENTIALS

B.S., Civil Engineering  
Civil Engineer in California, No. 53489  
Qualified SWPPP Developer in California, No. C53489 (SMARTS)  
Construction Quality Control Management Certificate; Previously Certified Project Management Professional; California Gold Award for Partnering; CAL/OSHA 10-Hour Construction Safety and Health Training

### **San Diego MTS El Cajon Third Track**

Mr. Mustafa is currently serving as Resident Engineer. This project is constructing an additional track and station platform modifications that enable both the Green and Orange Lines to terminate at the El Cajon Transit Center. These modifications will allow MTS to operate with ease over an intermittently delayed one-mile track segment between Gillespie Field Station and Santee, by introducing a two-car trolley shuttle at the El Cajon Transit Center. The El Cajon Transit Center currently has at grade tracks at Palm Avenue and are grade separated at Main Street. Mr. Mustafa's responsibilities include managing inspection staff and quality assurance testing. He is responsible for ensuring contractor compliance with contract documents as well as chairing weekly progress meetings. Furthermore, Mr. Mustafa reviews and responds to submittals and RFIs, and negotiates and generates contract change orders.

### **San Diego MTS Bayside Double Track IMT**

Mr. Mustafa serves as the Advisor to the Resident Engineer for MTS' Bayside Double Track IMT Project located at the 12th and Imperial Station in San Diego, CA. The project consists of a new second track on the Bayside Trolley Line, a new station platform, a new double crossover, upgrades to the overhead catenary system (OCS), modifications to the existing train signal system, reconstructing an access road, upgrades to drainage, and relocation of pedestrian canopy structures. Bid alternatives for other improvements include replacing several track turnouts, and upgrades to other site facilities. Mr. Mustafa is currently providing assistance to the Resident Engineer in managing inspection staff as well as assurance testing. He also assists in ensuring compliance with all contract documents and chairing weekly progress meetings. Moreover, Hassan aids in reviewing and responding to submittals and RFIs as well as negotiating and generating contract change orders.

### **San Diego MTS/SANDAG Orange Line Courthouse Station**

Mr. Mustafa served as the Resident Engineer for the \$6.8M Orange Line Courthouse Station project in San Diego, California. The project included construction of a new trolley station in downtown San Diego on C Street between Columbia Street and 1st Avenue, and the relocation of the Orange Line terminus from the Santa Fe Depot to the new station. The new station provides direct access to the new 22-story courthouse building, helps to relieve congestion at the Santa Fe Depot station, and improves overall service to the Downtown area. As Resident Engineer, Mr. Mustafa was responsible for all facets of construction management for the project including writing daily reports, generating and negotiating change orders, reviewing and commenting on submittals and RFIs, supervising multiple inspectors, coordinating with all stakeholders, generating Contractor payments, maintaining document control, and contract closeout.

### **City of Chula Vista On-call Construction Management Services, Major Pavement Rehabilitation FY 18/19 (STM0397)**

Mr. Mustafa served as a Resident Engineer on this \$2.2M pavement rehabilitation project for 17 locations on streets throughout the City. This project involved various types of asphalt concrete paving improvements including leveling courses, overlays using conventional hot mix or rubberized hot mix asphalt, and asphalt rubber aggregate membrane chip seal. Other improvements included concrete curb and gutter, ADA (Americans with Disabilities Act) curb ramps, sidewalk, and stamped concrete median, asphalt concrete dike, installation of vehicle detection loops, and permanent thermoplastic and paint striping. Mr. Mustafa was responsible for inspecting daily field work to ensure compliance with the contract plans and specifications, managing field staff and inspectors, writing daily logs, monitoring quantities to ensure no overruns, chairing weekly progress meetings, reviewing and responding to submittals and RFIs (Request for Information), and negotiating and writing contract change orders.



## Shawn Stewart (KCS)

### Civil Inspector

Shawn Stewart has over 30 years of progressive construction management and inspection experience on a wide range of projects, including pavement rehabilitation, annual slurry seal improvement projects, polyester concrete overlay, bridge deck and structure rehabilitation, roadway widenings, realignments and new alignments, trolley station improvements, light and heavy rail improvements, and bus facility improvements. He has provided inspection for mass grading, utilities infrastructure, drainage structures, pedestrian bridges, retaining walls, sidewalks, curbs and gutters, Americans with Disabilities Act (ADA) compliance and rehabilitation projects, hot-mix asphalt (HMA) paving, slurry seals, box culvert and storm drain channels, parking lots, and underground utilities. Mr. Stewart has excellent communication skills and has proven to be an effective client/owner representative by responding to concerns of local businesses and property owners impacted by adjacent projects. He is also well versed with inspection of SWPPP and Manual on Uniform Traffic Control Devices (MUTCD).

### EDUCATION/PROFESSIONAL CREDENTIALS

CAL/OSHA 10-Hour Construction Safety and Health Training  
Caltrans Construction Division Field Office Procedures Training  
MTS Roadway Worker Protection Training;  
NCTD Railroad Worker Protection Training;  
BNSF/UPRR Railroad Worker Protection Training

#### **SANDAG On-call Construction Management Services, Blue Line Station Rehabilitation and Rail Replacement**

Mr. Stewart served as a Civil Inspector on the \$58M Blue Line Station project. In this role, he was responsible for maintaining records of redline field modifications; ADA and Federal Railroad Administration (FRA) compliance; quality assurance inspection of platforms, shelters, and public right-of-way areas; traffic control (roadway and pedestrian); station acceptance; and release inspections. Mr. Stewart also performed field inspection for Trolley Overhead Contact Systems (OCS), foundations/poles, and signaling. Additional duties included performing public relations services to affected businesses and public entities during pre-construction, construction, and post-construction.

#### **SANDAG On-call Construction Management Services, Green Line Station Platform Modifications**

Mr. Stewart served as a Civil/Station Inspector on the Green Line Station Platform Modifications Project. This \$8.5M project consisted of modifications to eight stations to accommodate new low floor vehicles. Mr. Stewart was responsible for inspection of all work items on the platform modifications, including demolition, excavation, trenching, grading, structural, and minor concrete, as well as asphalt concrete (AC) paving and placement of station amenities. Mr. Stewart also represented SANDAG through their Public Outreach Program, communicating with residents, homeowner associations (HOAs), and local businesses throughout the duration of the project.

#### **SANDAG On-call Construction Management Services, South Bay Bus Rapid Transit Segment 1B**

Mr. Stewart served as a Civil Inspector on the South Bay Bus Rapid Transit (SBBRT) Segment 1B project. This segment of the SBBRT includes two new stations along a two-mile route, through the master planned Otay Ranch community of Chula Vista. The completed SBBRT provides frequent, rapid, and reliable bus service to help minimize traffic congestion along a major transportation corridor, offers service to areas not currently served by Rapid transit, and improve travel times by utilizing dedicated transit-only lanes, traffic signal priority, limited station stops, and real-time passenger information. Mr. Stewart was responsible for inspecting the civil improvements on the project, including grading, excavation and construction of the BRT guideway, utility service installations, and realignments and improvements. Additionally, he inspected storm drain piping, structures and tie-ins to existing storm drain facilities, recycled and potable water services, pathways and sidewalks, curb and gutter improvements including ADA improvements, hot-mix asphalt paving and overlays, signalization at the intersections, regulatory signage and striping, and landscaping and irrigation. He coordinated with Otay Water District, Department of Environmental Health, City of Chula Vista, and Federal Transportation Administration for barrier rail construction and public facilities inspection.

#### **SANDAG On-call Construction Management Services South Bay Bus Maintenance Facility Improvements Project**

Mr. Stewart served as a Senior Inspector for this \$5.5M project that consisted of upgrading the existing MTS bus maintenance facility and administration buildings located on Main Street in Chula Vista, California. His responsibilities included inspection of the demolition of existing building facilities, including HazMat and utility terminations, mass grading, new utility services, and existing service upgrades (electrical, water, fire, and communications). This project required coordination with multiple agencies such as SDG&E, Verizon, and City services, including water, sewer, storm drain, and fire services. Site improvements included over-excavation, grading, curb, gutter, asphalt paving, and slurry seal of parking lots.



## Vivan Chow (KCS)

### Office Engineer

Vivian Chow has five years of construction project administration and office engineering experience with background in the transportation, structural and miscellaneous steel, marine, and general construction sectors. Her responsibilities included preparing project submittals and RFIs, preparing monthly pay estimates, generating construction change orders (CCO), reviewing as-built markups, calculating extra work cost estimates, attending pre-construction building information modeling (BIM) meetings, field and marine surveying, project progress reporting, and document control. Ms. Chow has also served as a project engineer for a wide variety of construction projects including educational facilities and marine construction maintenance.

### EDUCATION/PROFESSIONAL CREDENTIALS

B.S., Engineering Management  
CAL/OSHA 10-Hour Construction Safety and  
Health Training

### **San Diego MTS El Cajon Third Track**

Ms. Chow is currently serving as Office Engineer. This project is constructing an additional track and station platform modifications that enable both the Green and Orange Lines to terminate at the El Cajon Transit Center. These modifications will allow MTS to operate with ease over an intermittently delayed one-mile track segment between Gillespie Field Station and Santee, by introducing a two-car trolley shuttle at the El Cajon Transit Center. The El Cajon Transit Center currently has at grade tracks at Palm Avenue and are grade separated at Main Street. Ms. Chow's responsibilities include drafting and transmitting construction change orders, preparing Q-sheets for monthly pay estimates, and producing independent cost estimates (ICE) for change order backup.

### **Caltrans District 11 Traffic Maintenance**

Ms. Chow served as office engineer for Caltrans District 11 Traffic Maintenance team. She drafted and transmitted construction change orders, prepared Q-sheets for monthly pay estimates, and produced independent cost estimates (ICE) for change order backup. As office engineer, she also observed night work asphalt paving operations related to the project change orders.

### **Caltrans District 11 Commercial Vehicle Enforcement Facility**

Ms. Chow served as Office Engineer for the Caltrans Commercial Vehicle Enforcement Facility (CVE) project. In her role as office engineer, she assisted in preparing and transmitting formal responses to RFI's and Submittals and maintaining RFI and Submittal logs. She attended weekly construction meeting and recorded and distributed meeting minute notes to the Contractor and Caltrans personnel. Ms. Chow also calculated item adjustment analyses, completed Utility Account Action Request forms, prepared Q-sheets for monthly pay estimates, and provided document control for the project.

### **SANDAG Mid-Coast Corridor Transit Project**

Ms. Chow served as Office Engineer for the SANDAG Mid-Coast Corridor Transit Project. In this role, she produced monthly pay estimates, verified construction in the field, reported project construction and financial progress on a weekly and monthly basis, resolved non-conformance reports, logged QC/QA inspections, performed force account analyses, prepared Q-sheets and validated contractor billings for payment, and conducted project close-out tasks including as-built marks-ups and document control. Ms. Chow also utilized SANDAG's cost management system (CMS) to draft and execute construction change orders; register bid item and extra work payments; and generate financial reports.

### **El Modena High School Science Center**

Ms. Chow served as project engineer for the construction of this high school science center building. In this role, she attended pre-construction BIM meetings to resolve construction conflicts with other sub-trades during the design process and provided steel delivery and erection dates for the project schedule. She was responsible for preparing shop drawing submittals, submitting inspection requests for shop welding and bolting during the fabrication process, RFIs, reviewing erection and shop drawings, and purchasing raw materials and logging material ID. Ms. Chow utilized Tekla to submit purchase orders for raw materials, reinforcement, and other resources necessary for fabrication; create cut lists for the CNC machine; and prepare shipping tickets for deliveries of steel members, tools, and equipment to the project site.

### **University of California, Riverside Plant Research 1**

Ms. Chow served as a Project Engineer for this state-of-the-art University of California Riverside project. Construction included a two-story, 30,000-square-foot building comprised of concrete, steel, and glass. The completed plant research facility is being used for agricultural sciences and research and includes 16 greenhouse modules that enable researchers to conduct experiments in various climate zone ranges. As a Project Engineer, Ms. Chow attended BIM meetings to coordinate structural design with other sub-trades. Additionally, she coordinated with the subcontractor to meet product deliverables and communicated with the project owner to discuss schedule adjustments.





## Mark Plotnikiewicz, PE, QSD (KCS)

### *Scheduling Engineer*

Mark Plotnikiewicz has 33 years of professional engineering experience providing construction management for a variety of transportation and public works projects as a Lead Schedule Engineer, Resident Engineer, Structures Representative, Lead Constructability Reviewer, and Design Engineer. He has served as a Senior Schedule Engineer and Constructability Reviewer for several large on-call contracts for owner/agencies such as SANDAG, San Diego MTS, Caltrans, and the City and County of San Diego; as well as for numerous high-profile projects like the MTS Orange Line Courthouse Station project, SANDAG Oceanside Transit Center Third Track and Platform Improvements project, SANDAG Sorrento to Miramar Double Track Phase 1, and many others. Mr. Plotnikiewicz is an expert at developing, reviewing, and accepting project baseline schedules; determining schedule impacts of proposed or required changes; developing Time Impact Analyses; and identifying methods to prevent potential schedule slips. He is well-versed in Primavera P6, Microsoft Project, and other scheduling software. Overall, Mr. Plotnikiewicz brings a comprehensive understanding of all aspects of construction management, including project management, contract oversight, constructability review, project scheduling, QA/QC oversight, civil and structural inspection, and client coordination.

### EDUCATION/PROFESSIONAL CREDENTIALS

B.S., Civil Engineering  
Civil Engineer in California, No. 58609  
Qualified SWPPP Developer in California, No. 20057  
CAL/OSHA 10-Hour Occupational Safety and Health Training

### **San Diego MTS El Cajon Third Track**

Mr. Plotnikiewicz is currently serving as Schedule Engineer. This project is constructing an additional track and station platform modifications that enable both the Green and Orange Lines to terminate at the El Cajon Transit Center. These modifications will allow MTS to operate with ease over an intermittently delayed one-mile track segment between Gillespie Field Station and Santee, by introducing a two-car trolley shuttle at the El Cajon Transit Center. The El Cajon Transit Center currently has at grade tracks at Palm Avenue and are grade separated at Main Street. Mr. Plotnikiewicz's responsibilities include reviewing the baseline schedule, monthly update schedules and Time Impact Analysis. He worked directly with the project team to provide an in-depth review of the schedule when the contractor significantly revised the proposed project staging.

### **San Diego MTS Bayside Double Track IMT**

Mr. Plotnikiewicz serves as the Schedule Engineer for MTS' Bayside Double Track IMT Project located at the 12th and Imperial Station in San Diego, CA. The project consists of a new second track on the Bayside Trolley Line, a new station platform, a new double crossover, upgrades to the overhead catenary system (OCS), modifications to the existing train signal system, reconstructing an access road, upgrades to drainage, and relocation of pedestrian canopy structures. Bid alternatives for other improvements include replacing several track turnouts, and upgrades to other site facilities. Mr. Plotnikiewicz's responsibilities include reviewing the baseline schedule, monthly update schedules and Time Impact Analysis.

### **San Diego MTS Orange Line Courthouse Station**

Mr. Plotnikiewicz served as Project Scheduler for this \$6.8M Orange Line Courthouse Station project in San Diego, California. The project included construction of a new trolley station in downtown San Diego on C Street between Columbia Street and 1st Avenue, and the relocation of the Orange Line terminus from the Santa Fe Depot to the new station. The new station provides direct access to the new 22-story courthouse building, helps to relieve congestion at the Santa Fe Depot station, and improves overall service to the Downtown area. Mr. Plotnikiewicz was responsible for reviewing baseline CPM schedules, monthly update schedules, and Time Impact Analyses (TIA). He prepared independent TIAs based on the project records to verify if the Contractor-prepared TIAs were valid and created "what-if" schedules to assess potential project impacts.

### **SANDAG On-call Construction Management Services, Kearny Mesa Bus Rapid Transit Constructability Reviews**

Mr. Plotnikiewicz served as the Project Manager and Lead Constructability Reviewer for the Kearny Mesa Bus Rapid Transit (BRT) project, which will consist of five new Rapid bus stations along Clairemont Mesa Boulevard and includes Transit Signal Priority (TSP) technology, new station shelters, lighting, digital displays, protected bike lanes, larger platforms, pedestrian ramps, striping, crosswalks, signage, and secure bike parking. As Project Manager, Mr. Plotnikiewicz implemented quality control procedures, verified reviews were performed thoroughly and accurately, prepared project deliverables, and monitored team performance on a frequent basis with SANDAG. Additionally, he was responsible for developing scope and fee estimates for each of the individual task orders. As a Constructability Reviewer, Mr. Plotnikiewicz was responsible for reviewing and creating CPM schedules, verifying proposed staging, establishing schedule efficiencies, and addressing areas of potential claims.



## **Chuck Wehsener, PE (CAWE)**

### **Lead Systems Engineer**

Charles Wehsener has over 32 years of experience in construction management and design of electrical facilities, including 13 years at Caltrans District 11 where he spent six years in the electrical design department and served as a Resident Engineer and Senior Construction Engineer in charge of all electrical construction in District 11. He has also had three years of experience with SANDAG where he was the Systems Engineer. Chuck founded C.A. Wehsener Engineering, Inc. over 10 years ago and serves as a consultant to numerous public agencies providing electrical construction management on rail and freeway projects.

### **EDUCATION/PROFESSIONAL CREDENTIALS**

B.S., Electrical Engineering  
Electrical Engineer in California, No. E14977

#### **SANDAG On-call Construction Management Services, Mid-Coast Trolley Extension Project**

Mr. Wehsener serves as Senior Construction Systems Manager on the \$2.1B Mid-Coast Corridor Transit project that will extend Trolley service from the Santa Fe Depot in downtown San Diego to the University City community, serving major activity centers such as Old Town, University of California San Diego, and the Westfield UTC mall. Project elements include nine stations, elevated structures, traction power and overhead catenary, railroad signal and systems communications, cut and cover, and two freeway crossings. Mr. Wehsener is responsible for providing quality assurance on over \$150M worth of work, including dry utility relocations; City of San Diego traffic signals and lighting; fiber optic communication systems for NCTD and MTS; and station electrical systems including buildings, elevators, and fire life safety systems.

#### **SANDAG On-call Construction Management Services, Various Projects**

Mr. Wehsener's work through this on-call contract has included a \$40M Railroad Signaling and Crossover project; \$5M Aerial Fiber Optic and Signal Cable Installation project; and six job order contracts installing fiber optic, electrical, and communication systems at trolley stations. Additionally, Mr. Wehsener assisted with coordinating the electrical work on the MTS Trolley's low floor improvement projects, which included more than 10 different contracts involving new stations and modifications to the signaling system. He has also done constructability reviews on station electrical and communications, fiber optic systems, roadway lighting and signalization, and building electrical systems.

#### **SANDAG Mission Valley East Track and Systems Contract**

Mr. Wehsener served as Project Manager/Resident Engineer on the \$47M Mission Valley East extension project, which involved installation of track and systems, including signaling, traction power, communications, and surveillance. Mr. Wehsener coordinated the systems work on the San Diego State University (SDSU) underground station which included intrusion protection, local operating network (LON), closed circuit television (CCTV), fire life safety, and radio communication. This required extensive coordination with SDSU, San Diego Fire Department, and San Diego Sheriff's Department.

#### **Caltrans District 11 On-call Construction Management Services, I-15 Corridor**

Mr. Wehsener served as Assistant Resident Engineer on 11 construction contracts along the I-15 corridor. His duties included negotiating change orders, reviewing design changes, coordinating tolling equipment installation, working with SDG&E on new service installations, testing fiber optic systems, working with Transportation Management Center (TMC) and IT staff on installation of network equipment, and assisting with the overall commissioning of electrical and communication systems. Mr. Wehsener also assisted with layout and design of the moveable barrier system guide wire and inspected the electrical systems associated with the Barrier Transfer Machine Maintenance Facility.

#### **Caltrans District 11 Electrical Construction Engineer, Various Projects**

Mr. Wehsener served as the District Electrical Construction Engineer supervising electrical inspectors assigned to all construction projects in District 11. His responsibilities included constructability reviews, cost estimating, change order concurrence and approval, and supervision. His staff provided all inspection on electrical systems and overhead sign installations. Mr. Wehsener also assisted the material department with inspection of electrical components.

#### **Caltrans District 11 Electrical Construction Engineer, Fiber Optic Communication Projects**

Mr. Wehsener served as Electrical Construction Engineer on various fiber optic communication projects totaling over \$20M. The projects included changeable message signs, traffic monitoring stations, and closed-circuit television camera systems all linked to the Caltrans Transportation Management Center through fiber optic communications. Mr. Wehsener also supervised inspection staff on Caltrans electrical projects including traffic signals, highway lighting, ramp metering, highway advisory radios, weigh-in-motion stations, and facilities electrical distribution systems.



## Thomas Wehsener, PE (CAWE)

### *Electrical/Communications Inspector*

## EDUCATION/PROFESSIONAL CREDENTIALS

Electrical Union Apprentices Program

Thomas Wehsener has over 30 years of experience in the electrical construction industry. He has served as project manager, estimator, and foreman on large industrial projects overseeing millions of dollars' worth of electrical work. He has been an inspector on large transportation projects and has been educated through the electrical union apprentice program.

### **SANDAG On-call Construction Management Services, Mid-Coast Trolley Extension Project**

Mr. Wehsener serves as Senior Construction Systems Manager on the \$2.1B Mid-Coast Corridor Transit project that will extend Trolley service from the Santa Fe Depot in downtown San Diego to the University City community, serving major activity centers such as Old Town, University of California San Diego, and the Westfield UTC mall. Project elements include nine stations, elevated structures, traction power and overhead catenary, railroad signal and systems communications, cut and cover, and two freeway crossings. Mr. Wehsener is providing quality assurance inspection for various items of work, including traffic signals and lighting, new meter services, utility relocations and street widening, as well as trolley systems such as overhead catenary system, traction power system, railroad signaling system, fiber optic network, station electrical systems, fire life safety, and building electrical systems.

### **SANDAG On-call Construction Management Services, Various Projects**

Mr. Wehsener served as an Electrical Inspector on the Aerial Fiber Optic installation Project, Green Line Station Modifications, Bus Maintenance Facility, Downtown Station Improvements, Blue Line Crossover and Signaling, and Blue Line Station Improvements. Mr. Wehsener ensured Contractor's work complied with contract plans and specifications, coordinated new electrical and telephone services with SDG&E and AT&T, and worked with SANDAG and MTS to standardize the stations' communication and electrical systems.

### **Caltrans District 11 I-15 Managed Lanes, Units 1, 2, and 3 South**

Mr. Wehsener served as an Electrical Inspector on Units 1, 2, and 3 South of the I-15 Managed Lanes project. The I-15 Managed Lanes project is a new 20-mile stretch of high-occupancy toll lanes constructed within the existing median along I-15 and allowing buses to enter and exit the highway via dedicated on- and off-ramps. Highway authorities manage the lanes by using a moveable median barrier to change the number of lanes in each direction depending on traffic flow. Project elements included lighting, traffic signals, ramp meters, fiber optic communication systems, changeable message sign systems, and closed-circuit television (CCTV) system. Mr. Wehsener ensured Contractor's work complied with contract plans and specifications. He additionally coordinated new services with SDG&E and AT&T.

### **Intuit Headquarters, Various Projects**

Mr. Wehsener served as Foreman responsible for the electrical work on a new office building for Intuit. The project included office space, commercial kitchen, and elevators. Mr. Wehsener's responsibilities included coordinating work with other trades, scheduling, working with city inspectors, and supervising electricians and subcontractors including elevator subcontractor.

### **Canyon Crest High School, Various Projects**

Mr. Wehsener served as a Foreman responsible for the complete electrical installation at Canyon Crest High School, including underground, distribution, transformers, panel boards, feeders, elevators, site lighting, and commercial kitchen. Mr. Wehsener's responsibilities included coordinating work with other trades, scheduling, working with City inspectors, and supervising electricians.



## Farzad Tasbihgoo, PhD, PE, CQA, CWI, PCI III (ZTC)

### Source Inspection Project Manager

Farzad Tasbihgoo is a registered civil engineer with the State of California, Certified Welding Inspector (CWI), and Certified Quality Auditor (CQA) with American Society for Quality (ASQ) with about 19 years of work experience in design, structure construction, and QC/QA on public transportation projects. He has a strong engineering design background with extensive experience in verification inspection, surveillance audits, and quality assurance services. He has assisted numerous local agencies in the design and construction of their public projects. He has developed and implemented QMP, SIQMP, and construction QC/QA specifications on numerous projects. Farzad has a well-earned reputation for his knowledge of Caltrans Standard Specifications and Greenbook specifications within Caltrans METS, District, and Structure Construction. He has extensive working knowledge of welding codes (AWS), weld inspection, and steel fabrication with railroad code (AREMA). He assisted Caltrans steel committee in implementing Electroslag Welding (ESW) requirements in one of the first Caltrans projects utilizing ESW in District 8.

### EDUCATION/PROFESSIONAL CREDENTIALS

PhD, Civil Engineering  
M.S., Structural Engineering  
B.S., Civil Engineering  
Professional Civil Engineer in California, No. 71403  
AWS CWI (FCM) in California, No. 11081291  
ACI Concrete Field-Testing Grade I, No. 1226819  
ASQ CQA, No. 67819  
PCI Level III No. 14342; PCI Level II No. 12221;  
PCI Level I No. 12222  
Executive Board Member of Southern California Construction Management Association of America (CMAA); UPRR Safety Training, 2016/2017; State of California - Safety Assessment Program - DSW Evaluator ID 64449

### LACMTA (Metro) Soundwall Package 11 (Los Angeles, CA)

The project is constructing sound walls along the State Route 170 and Interstate 405 Freeways in the City of Los Angeles and the County of Los Angeles. There are to be eight bridge widenings and 28,592 linear feet of sound wall and retaining walls. Mr. Tasbihgoo is the project senior quality engineer responsible in the development and implementation of project quality management plans for construction and source. He has reviewed numerous submittals, audit project quality activities, responded to RFIs, review fabricator's QC plans, and performed quality verification on various fabricators.

### RCTC I-15 Railroad Canyon Interchange (Lake Elsinore, CA)

The project will result in several major changes to the current interchange, including the following: two new lanes on Railroad Canyon Road through the interchange, reconstruction of the northbound diamond ramps to hook ramps to connect to Grape Street, construction of auxiliary and deceleration lanes on I-15, and construction of improved pedestrian and bicycle facilities through the interchange. As the Structural Material Representative, Mr. Tasbihgoo is preparing the Source Inspection Quality Management Plan (SIQMP) for Caltrans Oversight SMR, implementing the SIQMP, and coordinating and managing source fabrication, and structural material and electrical verification and testing. He also reviews fabrication submittals, such as PCQCPs, Shop Drawings, and Concrete Mix Designs.

### City of Los Angeles North Atwater Non-Motorized Multimodal Bridge (Los Angeles, CA)

This project was the construction of a cable-stayed steel bridge spanning over LA River supported on a single pier for pedestrian/cyclists, and equestrians. Mr. Tasbihgoo provided steel fabrication support. He reviewed all steel fabrication submittals such as shop drawings, welding quality control plan, and distortion plan. He developed the QC/QA inspection testing frequencies and specified NDT methods for welding verification. He reviewed welding reports, materials test results, NDT reports, and addressed numerous RFIs regarding the steel fabrication. He worked closely with the Designer, CM, City, and Fabricator QCM to resolve welding and fabrication challenges.

### RCTD I-15 & Limonite Interchange (East Vale, CA)

The project proposed replacing the Limonite Avenue overcrossing bridge with an overcrossing that is four lanes to six lanes wide. The existing Limonite Avenue OC was replaced, the roadway was widened from four lanes to six lanes, the ramps were reconstructed to provide a partial clover leaf (Type L-7), and loop ramps were constructed in the southeast and northwest quadrants. As the Structural Material Representative, Mr. Tasbihgoo prepared the Source Inspection Quality Management Plan (SIQMP) for Caltrans Oversight SMR, implemented the SIQMP, and coordinated and managed source fabrication, and structural material and electrical verification and testing.

## Andrew Soria, PCI III, ACI I, CWI (ZTC)

### QA Source Inspector

Andrew Soria is an experienced precast and steel inspector with about 17 years of experience in mix design, concrete placing, sampling, testing, and inspection of precast prestressed concrete girders and steel structures. He is a Precast Concrete Institute Certified Quality Control Level III (PCI III), which is the highest precast inspection certification that an inspector can achieve. He was the Quality Control Manager (QCM) and the lab manager for a large precast fabricator in Highlands, CA. He has managed and performed daily quality control inspections of precast fabrication. He was responsible for developing the concrete mix designs, preparing precast quality control plans (PCQCP), meeting with Caltrans and other public agency's Structural Material Representatives (SMRs) to address their questions, scheduling daily Quality Assurance (QA) inspections, generating RFIs, and resolving non-conformance reports (NCRs) both internal (QC) and from agencies (QA). He is a Certified Weld Inspector (CWI) and has vast knowledge of steel welding inspection.

### EDUCATION/PROFESSIONAL CREDENTIALS

Highschool Diploma  
Certified Welding Inspector in California, No. 20022691  
PCI Level III in California, No. 14594  
ACI Concrete Field-Testing Technician in California, No. 1260809  
CAL OSHA 10-Hour Training, Confined Spaces, Fall Protection

### **SBCTA SR-210 & Base Line Road** (San Bernardino, CA)

This project consists of making improvements to a portion of SR-210 0.1 mile east of Del Rosa Avenue to Lugonia Ave. These improvements consist of widening inside and outside lanes, the addition of one mixed flow lane in each direction in median, adding auxiliary lanes and acceleration/deceleration lanes at selected locations and improving Base Line Interchange at SR 210 from Sterling Ave to Lugonia Ave in cities San Bernardino, Highland and Redlands. As Quality Assurance (QA) Inspector, Mr. Soria is responsible for the sampling and release of various materials.

### **LACMTA (Metro) Soundwall Package 11** (Los Angeles, CA)

The project is constructing sound walls along the State Route 170 and Interstate 405 Freeways in the City of Los Angeles and the County of Los Angeles. There are to be eight bridge widenings and 28,592 linear feet of sound wall and retaining walls. Mr. Soria is the project lead QA inspector responsible for column casing welding and coating at jobsite. He performed in-process steel inspection for various column retrofits during course of column assembly for about 6 months. He is supporting other QA inspector in precast concrete inspection of precast prestressed girders.

### **City of Orange Public Works OSO Parkway** (Orange, CA)

The project will construct an overcrossing bridge structure at Oso Parkway and mainline roadway between the southern terminus of the State Route 241 (SR 241) toll road and the northern terminus of the future Los Patrones Parkway. As Quality Assurance (QA) Inspector, Mr. Soria is responsible for the visual inspection of bridge soffits, observing in-process NDE and visually inspecting the interior bays of bridges.

### **SANDAG Mid-Coast Corridor Transit Project** (Sequoia, CA)

The project construction extended the Trolley Blue Line service from Santa Fe depot to Downtown San Diego in City of San Diego, CA. Mr. Soria was the QC/QA precast Inspector for 144 precast prestressed post-tensioned Tub girders of unique design at Oldcastle Precast in Perris CA. He was responsible for observing and verifying the precast prestressed fabrication of Tub girders both straight and curved with post-tension ducts and prestressed strand. Curved girders designed with only PT. Mr. Soria inspected and released a total of 144 girders. He also sampled and tested strands, as well as verified concrete quality. Mr. Soria worked closely with MCTC QCM to address all the specifications requirements (PCQCP, Mix Design, Repair Procedures, etc.) and issues that arose during the precast concrete fabrication.

### **SBCTA Monte Vista Grade Separation** (Montclair, CA)

The project construction is replacing the at-grade Monte Vista Avenue and UPRR railroad tracks with an overpass in City of Montclair, CA. Mr. Soria was the QA precast Inspector for about 54,000 SF of MSE precast panels (about 2,200 precast panels) at Con-Fab Shafter. He was responsible for overseeing the precast prestressed fabrication of Bulb Tee I-girders with post-tensions. During a period of two and a half months, Mr. Soria inspected a total of 27 fabricated girders. He also sampled and tested strands, as well as verified concrete quality.



## Chad Davis, PE (KLF)

### Senior Materials Engineer

Mr. Davis has 30 years of experience in materials engineering, materials testing, pavement engineering, construction management, and project controls, serving a variety of public and private entities, including Caltrans Districts 8 and 11; SBCTA and SANDAG; the Cities of San Diego, Chula Vista, Moreno Valley, Carlsbad, and Santee; the Judicial Council of California; and Kaiser Healthcare. He is responsible for the assignment of qualified professional personnel and resources. Mr. Davis is knowledgeable of local codes and standards, as well as state, federal, and industry standards. His project experience includes a variety of large construction projects, including major building and infrastructure projects such as overpasses, grade separations, light and heavy rail, dams, bridges, hospitals, courthouses and high-rises.

### EDUCATION/PROFESSIONAL CREDENTIALS

MS, Business Administration  
BS, Civil Engineering  
Civil Engineer in California, No. 59908

#### **SANDAG, Mid-Coast Corridor Trolley Line, San Diego, CA**

Role: Project Manager and Materials Engineer. Scope: Managed up to four full-time field and laboratory technicians, coordinating field and laboratory activities, and providing consultation with MCTC design-build team's Quality Manager. He also coordinated with SBE and DBE partner subs for testing and inspection services. Phases included advanced wet utilities, Gilman Bridge and main line Segments 3 and 4. Testing and inspections included compaction testing; concrete inspection, sampling and testing; HMA sampling; and aggregate sampling. Project Cost: \$950M for all phases. Time Spent on Project: 2016–2017

#### **SANDAG, Sorrento Valley Double Track**

Role: Consultant Project Manager and Quality Engineer. Scope: Mr. Davis served as the Consultant Project Manager and Quality Engineer and was responsible for oversight of field testers and inspectors, as well as technical review of field reporting and materials engineering consultation. Time Spent on Project: 2015–2016

#### **Caltrans District 11 (Contract 11A3016-Prior 11A2364 and 11A2365 and Contracts 11A2466/11A2479), Construction Materials Sampling and Testing Services**

Role: Project Executive and Quality Engineer. Scope: Mr. Davis is responsible for internal quality assurance and oversight of field and laboratory testing and batch plant inspections for various projects throughout San Diego and Imperial Counties, as well as technical review of field and laboratory reporting and materials engineering consultation. Project Cost: \$200M on various EAs for each contract. Time Spent on Project: 06/2017 – Ongoing

#### **Los Angeles County Sanitation Districts, Mesquite Regional Landfill Rail Spur and Intermodal Yard**

Role: Resident Construction Quality Control Manager responsible for quality control testing and inspection for this \$40M waste-by-rail project consisting of a 5-mile rail spur, access road embankments, multiple bridges, drainage infrastructure, and an intermodal yard. Acted as an independent third-party consultant hired by the contractor but reporting to the owner/agency. The project included an on-site concrete batching and production of Class 2 base, concrete testing, tie and rail placement observation, ballast and rip-rap qualification testing, pile testing (gamma-gamma), structural steel welding and culverts, pre-cast concrete bridge girders, and roller-compacted concrete drainage channels. Time Spent on Project: 2010-2011

#### **City of San Diego, As-Needed Geotechnical and Materials Testing and Inspection Services**

Role: Project Executive/Task Order Manager. Scope: Mr. Davis has served as the Project Executive and as a Task Order Manager for various sewer and water group geotechnical investigations throughout the City of San Diego. Investigations included large neighborhood studies with traffic control design and permitting, private access coordination, and partner agency coordination with MTS and Caltrans. Mr. Davis also served as the reviewing engineer prior to final distribution of deliverables to the City. Time Spent on Project: 05/2018 – (03/2022)

#### **City of Chula Vista As-needed Geotechnical and Testing Services, Various Projects**

Mr. Davis serves as Project Executive and Task Order Manager for pavement investigations and pavement rehabilitation projects throughout the City totaling \$200K, including ARAM, chip seal, mill & overlay rehabilitation projects, and preliminary field studies for pavement section assessment through coring and exploration.

#### **Caltrans District 8 On-call Field Testing Services, Riverside and San Bernardino Counties**

Mr. Davis served as the Consultant Project Manager and Quality Engineer and was responsible for oversight of field testers and batch plant inspections throughout San Bernardino and Riverside Counties, as well as technical review of field reporting and materials engineering consultation.



## Jesse Gastelum (KLF)

### Materials Tester

Jesse Gastelum is a trained field and laboratory technician in soils, concrete and asphalt. He has expertise in field grading observations and testing, field testing and documentation, laboratory testing, documentation of concrete and density testing, and special inspections and supervisions of construction monitoring for highway and roadway improvements. Mr. Gastelum is currently providing materials sampling and testing services at several projects within Caltrans District 11.

### EDUCATION/PROFESSIONAL CREDENTIALS

High School Diploma  
ACI Concrete Field Testing Technician – Grade I  
Certified in Caltrans Test Methods: 105, 106, 125 (AGG, GEN, HMA), 201, 202, 205, 216, 217, 226, 227, 229, 504, 518, 533, 539, 540, 543, 556, 557; AASHTO Test Methods: T11, T27, R47, R76, T166, T176, T209, T255, T269, T275, T308, T329, T335

### **SANDAG/Caltrans, I-5 San Elijo Lagoon Bridge Replacement**

Mr. Gastelum has served as a Construction Materials Tester on this project. Mr. Gastelum provides quality assurance materials testing for this project that is part of an on-call materials testing contract with SANDAG and Caltrans District 11. His services included compaction testing, concrete sampling and testing for structures and pavement (JPCP).

### **Caltrans District 11 (Contract 11A3016-Prior 11A2364 and 11A2365 and Contracts 11A2466/11A2479), Construction Materials Sampling and Testing Services**

Mr. Gastelum is currently providing materials sampling and testing services at several projects through District 11 under Kleinfelder's on call contract. Duties include traveling to job sites and batch plants to perform concrete sampling, concrete field testing and soils compaction testing. Report all test data directly to Resident Engineer to notify of any discrepancies or issues with tests results or observations. He performs hot plant inspections along with sampling of aggregate, oil binders and HMA. Samples are gathered as per CT 125 and Imperial County sampling procedure for HMA. Performed various laboratory tests at District 11 laboratory, including asphalt tests procedures as per AASHTO and Caltrans. Testing performed for Job Mix Formulas, startup evaluations and production of various super pave projects. Worked closely with and maintained open communication with onsite Inspectors, field personnel and engineers. Due to the nature of the work performed.

### **Caltrans, Interstate 8 Reconstruction, Materials Testing Services**

Mr. Gastelum performed field and laboratory materials testing services as part of this As-Needed contract with Caltrans District 11 (11A2364), Task Order 02. The project is divided by 3 segments: Segment 1 (EA 11-413604) from El Centro to before 98/8 separation; Segment 2 (EA 11-413704) from 98/8 separation; and Segment 3 (EA 11-416894) around Winterhaven. The testing scope includes testing the subgrade, base materials where subgrade and /or base is exposed. Superpave HMA is utilized underneath the CRCP, on-off ramps, and shoulders.

### **County of San Diego, On-Call Geotechnical Engineering Testing and Inspection Services**

Mr. Gastelum has provided materials testing services for numerous County Department of Public Works projects. Services have included soil testing and concrete and asphalt testing and sampling per Caltrans and ASTM procedures. He has performed paving inspection services under the guidelines of Greenbook and Caltrans Section 39. While working on these projects reported directly to the County of San Diego Inspectors and Resident Engineers.

### **Imperial County Public Works, On-Call Services for Testing and Laboratory Work**

Mr. Gastelum provided materials testing services for numerous county road projects. Services included batch plant inspections, field soil, concrete and asphalt testing and sampling as per Caltrans and ASTM procedures. Performed paving inspection services under the guidelines of Greenbook and Caltrans Section 39. Compiled test and inspection information for Geotechnical Engineer.



## Oscar Noriega, CWI (KLF)

### *Certified Welding Inspector*

Mr. Noriega has 25 years of experience in the commercial construction industry; for much of this time, he served as a journeyman ironworker specializing in steel and reinforced/prestressed concrete construction. As an inspector, he has incorporated this journeyman experience and the construction process into his inspection responsibilities. This provides clients with insight into overcoming possible delays and the ability to work with the contractor to achieve compliance with the approved construction documents.

#### **County of San Diego, Courthouse Commons Tunnel and Transfer Shaft**

Mr. Noriega served as the primary Special Inspector for this new below-grade Courthouse Commons Tunnel and transfer shaft in downtown San Diego. The Transfer Facilities Shaft and tunnel connected the County Central Jail with the new State Courthouse. The 23-foot-diameter modified horseshoe tunnel is approximately 320 feet long and 60 feet deep. The Transfer Facilities Shaft is a three-story underground structure immediately adjacent to and connected with the existing Central Jail. The shaft is supported by a combination of secant piles and soldier piles and lagging with three bracing levels.

#### **City of San Diego, West Mission Bay Drive Bridge**

Mr. Noriega serves as Technician on this project. Kleinfelder provided source inspection and quality assurance services as a subconsultant to Kleinfelder Construction Services (KCS) for the City of San Diego \$110M West Mission Bay Drive Bridge (WMBDB) project over the San Diego River. This complex project required staged construction and consists of two cast-in-place reinforced concrete box girder bridges supported by deep pile foundations 166 feet below sea level. Kleinfelder's supplemental materials testing and inspection services included embankment and backfill observation, soil compaction testing, inspection of reinforced concrete, post-tension inspection, shop and field welding inspection, observation and testing of asphalt paving, and gamma-gamma testing of CIDH piles.

#### **Grossmont College Math, Science and Career Tech Center, Ph 2**

Mr. Noriega served as the lead special inspector for this new \$45M two story building of approximately 61,390 GSF for over a year. His responsibilities included special inspection of all structural steel and high strength bolting, spray-applied fireproofing, anchors, concrete, pull-testing and more. Inspections are completed in a timely manner with continuous communication with the contractor and reporting directly to the DSA IOR.

#### **San Diego Community College District, Child Development Center**

Mr. Noriega served as the Lead Special Inspector performing special inspection services including reinforced concrete, anchors, and fireproofing. He coordinated and oversaw masonry, soil and ACI technicians and inspectors on the project. Inspections were completed in a timely manner with continuous communication with the contractor and reporting directly to the DSA IOR.

#### **University of California, San Diego (UCSD) 5149 Design Innovation Building**

Mr. Noriega has provided support to our lead inspector on this project. His duties have included reinforcing steel inspection, concrete sampling, and testing. His ability to work with the IOR and the contractor has been valuable to the project.

#### **UCSD 5079 Mesa Housing Pedestrian and Bike Bridge**

Mr. Noriega has provided support to our lead inspector on this new pedestrian and bike bridge. His duties have included welding inspection for the artistic handrail, reinforcing steel inspection, and concrete inspection and sampling.

#### **Simon Property Group, Inc., Fashion Valley Mall Renovation**

Mr. Noriega provided special inspection services including structural welding for new elevator and various structural upgrade, concrete sampling and testing, and masonry for the renovated planters. His ability to work on night shift and with the contractor has been valuable to the project progress.

### EDUCATION/PROFESSIONAL CREDENTIALS

High School Diploma  
American Concrete Institute  
American Welding Society Certified Welding Inspector  
City of San Diego Special Inspector  
Division of the State Architect  
International Code Council (ICC) Certification:  
Pre-Stressed Concrete, Reinforced Concrete,  
Spray-Applied Fireproofing, Structural Masonry,  
Structural Steel/Welding  
IFC Premier Firestopping  
Nuclear Gauge Operator Trained



## Amy Comte, CPESC, CESSWI, QSD/P, ToR (TRC)

### Stormwater Inspector

Ms. Comte has more than 19 years of experience in the construction industry. Her experience includes water quality monitoring, inspection, plan preparation and review, NPDES inspections, and leading NPDES training sessions. She is a member of the California Storm Water Quality Association and is a Trainer of Record. Facilitated Qualified SWPPP Developer (QSD) and Qualified SWPPP Practitioner (QSP) training course for TRC's internal staff and various clients. The training sessions occur over a three-day period and cover eight training modules to containing required content. Modules are titled as follows; Training Overview and Regulations, Erosion Process and Sediment Control, SWPPP Implementation, Construction Site Monitoring, Reporting, Project Planning and Risk Determination, SWPPP Preparation, and Project Closeout. Minimum contact hours were achieved for each QSD / QSP participant and covered topics including but not limited to; CGP, Linear Underground / Overhead Requirements, Risk Analysis, Active Treatment Systems (ATS), Low Impact Development (LID) and sampling techniques.

### EDUCATION/PROFESSIONAL CREDENTIALS

B.A., Geography

Water Quality Courses, 2003-2008:

Construction General Permit Trainer of Record  
Caltrans Water Pollution Control Manager Course  
NPDES Basic Training  
Caltrans 24 Hour Course  
Construction Water Pollution Control Course  
Water Quality Management Plan Course  
Industrial and Commercial Facility Activities Course  
CPESC Exam Course Review  
DOT Hazardous Material Transportation Awareness

### **SANDAG, On-Call Professional and Technical Construction Management and Engineering Services South Bay Bus Rapid Transit Segment 1A (Chula Vista, CA)**

Ms. Comte provided project storm water services on t/his risk level 1 designated project. Duties included reviewing the contractor prepared SWPPP and amendments for completeness and accuracy, conducting weekly site inspections independently and with the contractor, weather monitoring, inspecting temporary BMP installation, and ensuring the contractor complied with the Construction General Permit. Maintained contractor correspondence and attended meetings to discuss storm water regulations with the contractor to ensure compliance with the Construction General Permit and Contract Special Provisions requirements. Assisted the office engineer staff with components of Category 20. Acted as a data submitter in SMARTS to assist the Legally Responsible Person with reporting and filing requirements.

### **SANDAG, South Bay Bus Rapid Transit Segments 2 and 3 (San Diego, CA)**

Ms. Comte provided project storm water services on this risk level 2 designated project within the Caltrans Right of Way. Duties included reviewing the contractor prepared SWPPP and amendments for completeness and accuracy, conducting weekly site inspections independently and with the contractor, weather monitoring, inspecting temporary BMP installation, and ensuring the contractor complied with the Construction General Permit. Assisted the resident engineer by keeping regular correspondence with the contractor and attending meetings to discuss storm water regulations with the contractor to ensure compliance with the Construction General Permit and Contract Special Provisions requirements. Assisted the office engineer staff by maintaining all components of Category 20. Acted as a data submitter in SMARTS to assist the Legally Responsible Person with reporting and filing requirements.

### **SANDAG, South Bay Bus Rapid Transit Segment 1B (Chula Vista, CA)**

Ms. Comte provided project storm water services on this risk level 2 designated project. Duties included reviewing the contractor prepared SWPPP and amendments for completeness and accuracy, conducting weekly site inspections independently and with the contractor, weather monitoring, inspecting temporary BMP installation, and ensuring the contractor complied with the Construction General Permit. Assisted the resident engineer by keeping regular correspondence with the contractor and attending meetings to discuss storm water regulations with the contractor to ensure compliance with the Construction General Permit and Contract Special Provisions requirements. Assisted the office engineer staff by maintaining all components of Category 20. Acted as a data submitter in SMARTS to assist the Legally Responsible Person with reporting and filing requirements.

### **SANDAG, Pershing Drive Bikeway and Roadway Improvements Project (San Diego, CA)**

Ms. Comte provides project stormwater services on this risk level 1 designated project within the Caltrans ROW. The \$12 million Pershing Drive Bikeway and Roadway Improvements Project consists of 2.6 miles of Class IV bikeway and parallel roadway improvements along Pershing Drive in the City of San Diego. Planned features are designed to help transform Pershing Drive into a "low-stress" street that will promote safety for people walking, biking and driving. Ms. Comte's duties include reviewing the contractor prepared SWPPP and amendments for completeness and accuracy, conducting weekly site inspections independently and with the contractor, weather monitoring, inspecting temporary BMP installation, and verifying the contractor complied with the Construction General Permit. She assists the resident engineer by keeping regular correspondence with the contractor and attending meetings to discuss stormwater regulations with the contractor for compliance with the Construction General Permit and Contract Special Provisions requirements. Ms. Comte assists the office engineer staff by maintaining all components of Category 20, and she acts as a data submitter in SMARTS to assist the Legally Responsible Person with reporting and filing requirements.



**Kleinfelder Construction Services, Inc.**

5761 Copley Drive, San Diego, CA 92111  
P: 858-223-8500 | F: 858-223-8499

ATTACHMENT B  
NEGOTIATED FEE PROPOSAL

DRAFT

# Work Order Estimate Summary

Att.A, AI 15, 04/25/24

MTS Doc. No. **G2498.0-21**

Work Order No. **WOA2498-CM19**

Attachment: **B**

Work Order Title: **Iris Rapid Bus Stops and Transit Center East  
Construction Management Services**

Project No: **WOA2498-CM19**

**Table 1 - Cost Codes Summary (Costs & Hours)**

Item	Cost Codes	Cost Codes Description	Total Costs
1	0270	Construction Management and Inspection Services	\$900,510.13

Totals = **\$900,510.13**

**Table 2 - TASKS/WBS Summary (Costs & Hours)**

Item	TASKS/WBS	TASKS/WBS Description	Labor Hrs	Total Costs
1	1	PROJECT/WORK ORDER MANAGER	40	\$7,505.29
2	2	PRE-CONSTRUCTION SERVICES	238	\$52,134.90
3	3	CONSTRUCTION PHASE SERVICES	3,938	\$840,869.95

Totals = **4,216**      **\$900,510.13**

**Table 3 - Consultant/Subconsultant Summary (Costs & Hours)**

(If Applicable, Select One)				Consultant	Labor Hrs	Total Costs
DBE	DVBE	SBE	Other			
			X	Kleinfelder - Construction Services	2,936	\$592,675.37
			X	Kleinfelder	262.0	\$83,847.41
		X		CA Wehsener Engineering	510.0	\$97,823.63
			X	ZT Consulting	212.0	\$41,298.99
			X	TRC Engineers	296.0	\$84,864.74

Totals = **4,216**      **\$900,510.13**

**NOTES**

- Field inspection and materials testing rates have been adjusted as necessary to comply with prevailing wage DIR Determination SD-23-63-3-2021-1D. Rates are calculated using assumed fringe value of \$12/hr. Actual rates are calculated monthly per SANDAG direction.
- Billing rates included in this cost proposal are based upon the published rate table incorporated into Contract G2498.0-21 and as finalized by SANDAG under Contract 550870

Consultant/Subconsultant: **Kleinfelder - Construction Services**

Total Hours = **2,936**  
 Total Costs = **\$592,675.37**

Work Order Title: **Iris Rapid Bus Stops and Transit Center East Construction Management Services**

Item	TASKS/WBS	TASKS/WBS Description	ODCs (See Attachment)	Beringhaus, Michalle	Beringhaus, Michalle	Berrios, Jesus	Berrios, Jesus	Stewart, Shawn	Stewart, Shawn	Gentile, Hank	Gentile, Hank	Mustafa, Hassan
				Task Order Manager	Task Order Manager	Project Controls III	Project Controls III	Civil Inspector- PW Grp 2	Civil Inspector- PW Grp 2	Contract Manager	Contract Manager	Engineer, Supervising
				FY 23/24	FY 24/25	FY 23/24	FY 24/25	FY 23/24	FY 24/25	FY 23/24	FY 24/25	FY 23/24
				\$ 214.15	\$ 219.93	\$ 153.18	\$ 157.32	\$ 164.11	\$ 168.54	\$ 291.01	\$ 298.87	\$ 237.94
1	<b>TASK 1.0</b>	<b>PROJECT/WORK ORDER MANAGER</b>										
		PROJECT/WORK ORDER MANAGER		\$0.00	4	16	4	16				
		Subtotals (Hours) =	N/A	4	16	4	16	0	0	0	0	0
		Subtotals (Costs) =	\$0.00	\$856.60	\$3,518.91	\$612.72	\$2,517.05	\$0.00	\$0.00	\$0.00	\$0.00	\$0.00
2	<b>TASK 2.0</b>	<b>PRE-CONSTRUCTION SERVICES</b>										
		PRE-CONSTRUCTION SERVICES		\$1,445.85				40		8		40
		Subtotals (Hours) =	N/A	0	0	0	0	40	0	8	0	40
		Subtotals (Costs) =	\$1,445.85	\$0.00	\$0.00	\$0.00	\$0.00	\$6,564.31	\$0.00	\$2,328.08	\$0.00	\$9,517.60
3	<b>TASK 3.0</b>	<b>CONSTRUCTION PHASE SERVICES</b>										
		CONSTRUCTION PHASE SERVICES		\$19,966.50				176	1208	8	64	88
		Subtotals (Hours) =	N/A	0	0	0	0	176	1208	8	64	88
		Subtotals (Costs) =	\$19,966.50	\$0.00	\$0.00	\$0.00	\$0.00	\$28,862.97	\$203,594.72	\$2,328.08	\$19,127.51	\$20,938.72
<b>Totals (Summary) =</b>												
	Total (Hours) =	N/A		4	16	4	16	216	1208	16	64	128
	Total (Costs) =	\$21,412.35	\$856.60	\$3,518.91	\$612.72	\$2,517.05	\$35,447.28	\$203,594.72	\$4,656.16	\$19,127.51	\$30,456.32	
	Percentage of Total (Hours) =		0%	1%	0%	1%	7%	41%	1%	2%	4%	
	Percentage of Total (Costs) =	4%	0%	1%	0%	0%	6%	34%	1%	3%	5%	

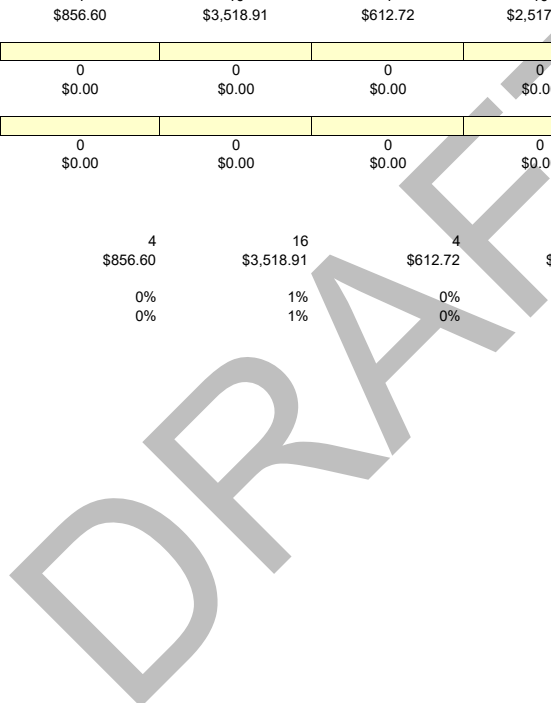

Total Hours =	<b>2,936</b>
Total Costs =	<b>\$592,675.37</b>

MTS Doc. No.: **G2498.0-21**  
 Work Order No.: **WOA2498-CM19**  
 Attachment: **B**

Item	TASKS/WBS	TASKS/WBS Description	Mustafa, Hassan	Chow, Vivian	Chow, Vivian	Plotnikiewicz, Mark	Plotnikiewicz, Mark	Total Hours	Totals
			Engineer, Supervising FY 24/25	Engineer II FY 23/24	Engineer II FY 24/25	Scheduler, Technical Expert FY 23/24	Scheduler, Technical Expert FY 24/25		
			\$ 244.36	\$ 149.90	\$ 153.95	\$ 231.07	\$ 237.31		
1	<b>TASK 1.0</b>	<b>PROJECT/WORK ORDER MANAGER</b>							
		PROJECT/WORK ORDER MANAGER						40	\$7,505.29
		Subtotals (Hours) =	0	0	0	0	0	40	\$7,505.29
		Subtotals (Costs) =	\$0.00	\$0.00	\$0.00	\$0.00	\$0.00	40	\$7,505.29
2	<b>TASK 2.0</b>	<b>PRE-CONSTRUCTION SERVICES</b>							
		PRE-CONSTRUCTION SERVICES		40	40	40	40	168	\$35,094.64
		Subtotals (Hours) =	0	40	0	40	0	168	\$35,094.64
		Subtotals (Costs) =	\$0.00	\$5,996.00	\$0.00	\$9,242.80	\$0.00	168	\$35,094.64
3	<b>TASK 3.0</b>	<b>CONSTRUCTION PHASE SERVICES</b>							
		CONSTRUCTION PHASE SERVICES	664	40	320	40	120	2,728	\$550,075.44
		Subtotals (Hours) =	664	40	320	40	120	2,728	\$550,075.44
		Subtotals (Costs) =	\$162,257.95	\$5,996.00	\$49,263.14	\$9,242.80	\$28,477.07	2,728	\$550,075.44
		<b>Totals (Summary) =</b>						<b>2,936</b>	<b>\$592,675.37</b>
		Total (Hours) =	664	80	320	80	120	2,936	
		Total (Costs) =	\$162,257.95	\$11,992.00	\$49,263.14	\$18,485.60	\$28,477.07		\$592,675.37
		Percentage of Total (Hours) =	23%	3%	11%	3%	4%	100%	
		Percentage of Total (Costs) =	27%	2%	8%	3%	5%		100%

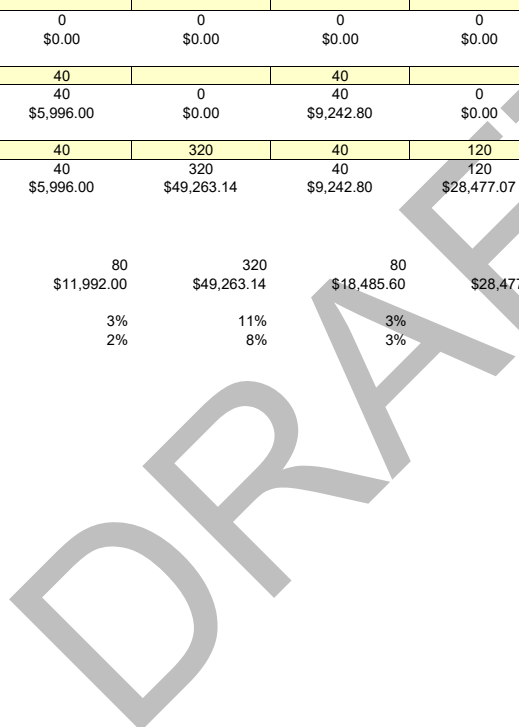

**Work Order Estimate  
Summary**

Consultant/ Subconsultant: **Kleinfelder - Construction Services**

Contract No: **G2498.0-21**

Task Order No. **WOA2498-CM19**

Work Order Title: **Iris Rapid Bus Stops and Transit Center East Construction Management Services**

Attachment: **B**

ODC Item	Description	Unit	Unit Cost	Task 1		Task 2		Task 3		Task 4		Task 5	
				Quantity	Total	Quantity	Total	Quantity	Total	Quantity	Total	Quantity	Total
1	Field Vehicle	Month	\$1,377.00			1.05	\$1,445.85	17.1	\$19,966.50				
2													
3													
4													
5													
6													
				Subtotal =		Subtotal =	<b>\$1,445.85</b>	Subtotal =	<b>\$19,966.50</b>	Subtotal =		Subtotal =	<b>\$21,412.35</b>

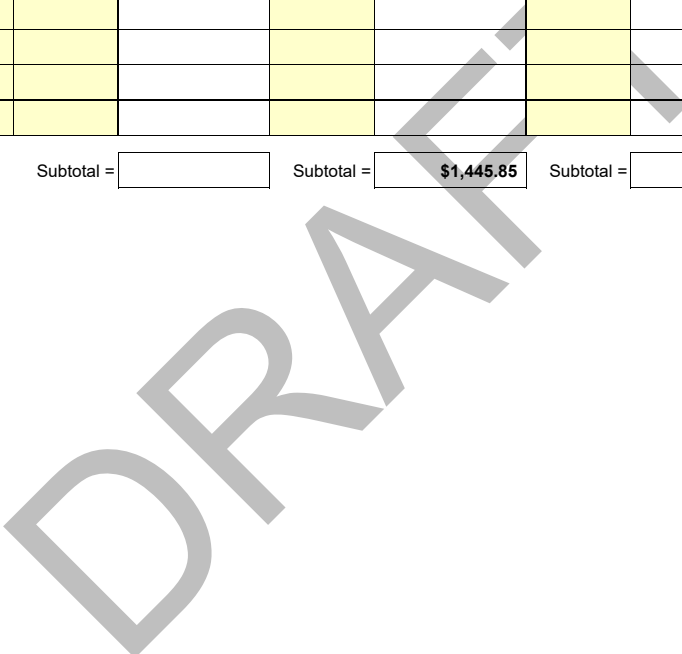

STATE OF CALIFORNIA - DEPARTMENT OF TRANSPORTATION

COST PROPOSAL

ON-CALL CONTRACT- OH & FEE ON DELTAS, WITH PREDETERMINED INCREASE, DIRECT LABOR METHOD OF ACCOUNTING

ADM 2033 (Rev. 10/23/18)

Determination Number: ~~0623-63-3-2021-1D~~

- Issue Date: August 22, 2021
- Effective Date: September 1, 2021
- Expiration Date: \*June 30, 2022

Consultant/Subconsultant Name: KCS

Agreement Number: G2498.0-21  
Attachment 2

Date Prepared: 6/13/2023  
Page No.: 1 of 1

**Loaded Billing Rate Calculations:**

**Non-Exempt Employee Loaded Billing Rates:**

A) Straight Time (ST) Loaded Billing Rate = [Actual Hourly Rate + ST Delta Base + ST Delta Fringe] \* [(1 + Field OH) \* (1 + Fee)]

B) ST Loaded Billing Rate + (1.5 Base PW Rate - ST Base PW Rate)\*[(1+Field OH) \* (1+Fee)] or ST Loaded Billing Rate + (2.0 Base PW Rate - 1.5 Base PW Rate) \*[(1+Field OH) \* (1+Fee)]

**Exempt Employee Loaded Billing Rates- Compensated for PW OT:**

C) Straight Time (ST) Loaded Billing Rate = [Actual Hourly Rate + ST Delta Base + ST Delta Fringe] \* [(1 + Field OH) \* (1 + Fee)]

D) ST Loaded Billing Rate + (1.5 Base PW Rate - ST Base PW Rate)\*[(1+Field OH) \* (1+Fee)] or ST Loaded Billing Rate + (2.0 Base PW Rate - 1.5 Base PW Rate) \*[(1+Field OH) \* (1+Fee)]

**The PW Deltas (Base & Fringe) above for Loaded Billing Rates, are applicable for services covered under DIR determinations. Includes Exempt employees who are normally not paid for OT worked, per company policy.**

**Exempt Employee Loaded Billing Rates- Not Compensated for OT (Uncompensated OT):**

E) ST Loaded Billing Rate = Actual Hourly Rate \* [(1 + Home OH) \* (1 + Fee)]

F) No Overtime. Columns are shaded out - See Stevie Ray Vaughn Non-Prevailing Wage example, line 59.

**Exempt Employee Loaded Billing Rates- Compensated for OT @ ST Rate:**

G) ST Loaded Billing Rate = Actual Hourly Rate \* [(1 + Home OH) \* (1 + Fee)]

H) ST Loaded Billing Rate + (1.5 x 0) or ST Loaded Billing Rate + (2.0 x 0) See example for Bob Marley, line 47 and Alecia Moore, line 65, both Non-Prevailing Wage Work.

Home Office:	Fringe Benefit %	Overhead %	General Administration %	Combined %
NORMAL	=			107.82%
OVERTIME	=			107.82%
Field Office:	Fringe Benefit %	Overhead %	General Administration %	Combined %
NORMAL	=			107.82%
OVERTIME	=			107.82%
Project Specific:	Fringe Benefit %	Overhead %	General Administration %	Combined %
NORMAL	=			107.82%
OVERTIME	=			107.82%

FEE	=	8.50%
FCCM	0.10%	
Applicable Delta Base Multiplier (Field/Home)	=	2.25485
Applicable Delta Fringe Multiplier Fringe (Field)	=	2.25485

Name & Work Information	Home / Field / Project Specific Personnel	Prevailing Wage Rate established by State DIR (only applicable for prevailing wage work)						Employee Actual Rate (fringe benefits vary year over year)						Applicable DELTA (TOTAL) = Employee Total - DIR Total		Applicable DELTA Base = DIR Rate - Employee Base Rate			Applicable DELTA FRINGE = DELTA TOTAL - DELTA BASE (Employee - DIR)			Loaded Hourly Billing Rates			Effective Date of Hourly Rate [Add RFQ/RFP Advertisement Date]		% Escalation Increase	Actual Hourly Rate	Hourly Range for Class						
		Base Salary		Fringe Benefits	Base Salary + Fringe Benefits		Base Salary		Actual Fringe	Total = Base + Fringe		1.5 OT	2.0 OT	1.5 OT	2.0 OT	Straight	1.5 OT	2.0 OT	Straight	1.5 OT	2.0 OT	Straight	1.5 OT	2.0 OT	From	To									
		Straight	1.5 OT		2.0 OT	Straight	1.5 OT	2.0 OT		Straight	1.5 OT																			2.0 OT	Straight	1.5 OT	2.0 OT	Straight	1.5 OT
Stewart, Shawn Building Inspector Group 2 PW	FIELD	\$54.46	\$81.69	\$108.92	\$32.79	\$87.25	\$114.48	\$141.71	<b>\$72.78</b>	\$109.17	\$145.56	\$15.86	\$88.64	\$125.03	\$161.42	\$0.00	\$0.00	\$0.00	\$0.00	\$0.00	\$0.00	\$0.00	\$0.00	\$0.00	\$0.00	\$0.00	\$164.11	\$246.16	\$328.22	7/1/2023	6/30/2024	0.00%	\$ 72.78	N/A	
		\$54.46	\$81.69	\$108.92	\$32.79	\$87.25	\$114.48	\$141.71	<b>\$74.75</b>	\$112.12	\$149.49	\$15.86	\$90.61	\$127.98	\$165.35	\$0.00	\$0.00	\$0.00	\$0.00	\$0.00	\$0.00	\$0.00	\$0.00	\$0.00	\$0.00	\$0.00	\$0.00	\$0.00	\$168.54	\$252.81	\$337.08	7/1/2024	6/30/2025		2.70%
4. Non-Exempt 5. Full Time	Prevailing Wage Work REG SHIFT	\$54.46	\$81.69	\$108.92	\$32.79	\$87.25	\$114.48	\$141.71	<b>\$76.76</b>	\$115.14	\$153.53	\$15.86	\$92.62	\$131.00	\$169.39	\$0.00	\$0.00	\$0.00	\$0.00	\$0.00	\$0.00	\$0.00	\$0.00	\$0.00	\$0.00	\$0.00	\$0.00	\$173.09	\$259.63	\$346.18	7/1/2025	6/30/2026	2.70%		\$ 76.76
		\$54.46	\$81.69	\$108.92	\$32.79	\$87.25	\$114.48	\$141.71	<b>\$78.84</b>	\$118.25	\$157.67	\$15.86	\$94.70	\$134.11	\$173.53	\$0.00	\$0.00	\$0.00	\$0.00	\$0.00	\$0.00	\$0.00	\$0.00	\$0.00	\$0.00	\$0.00	\$0.00	\$177.76	\$266.64	\$355.53	7/1/2026	6/30/2027	2.70%		\$ 78.84
		\$54.46	\$81.69	\$108.92	\$32.79	\$87.25	\$114.48	\$141.71	<b>\$80.96</b>	\$121.45	\$161.93	\$15.86	\$96.82	\$137.31	\$177.79	\$0.00	\$0.00	\$0.00	\$0.00	\$0.00	\$0.00	\$0.00	\$0.00	\$0.00	\$0.00	\$0.00	\$0.00	\$182.56	\$273.84	\$365.12	7/1/2027	6/30/2028	2.70%		\$ 80.96
		\$54.46	\$81.69	\$108.92	\$32.79	\$87.25	\$114.48	\$141.71	<b>\$83.15</b>	\$124.73	\$166.30	\$15.86	\$99.01	\$140.59	\$182.16	\$0.00	\$0.00	\$0.00	\$0.00	\$0.00	\$0.00	\$0.00	\$0.00	\$0.00	\$0.00	\$0.00	\$0.00	\$187.49	\$281.24	\$374.98	7/1/2028	6/30/2029	2.70%	\$ 83.15	

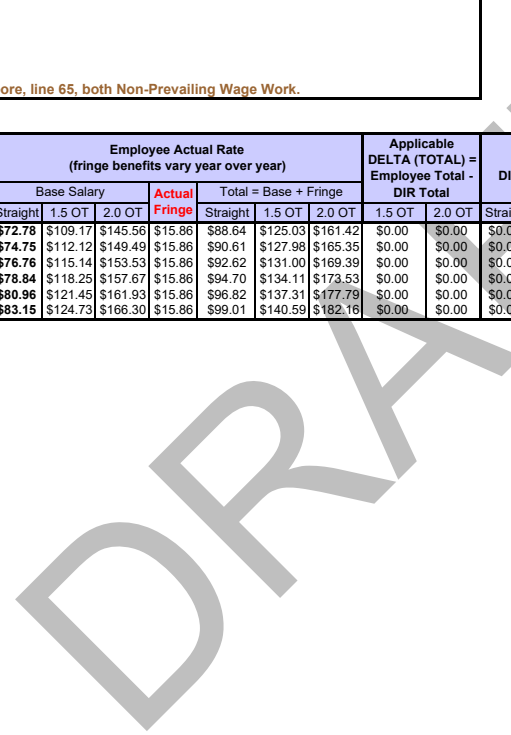



Total Hours = **262**  
 Total Costs = **\$83,847.41**

Consultant/Subconsultant: **Kleinfelder**

MTS Doc. No.: **G2498.0-21**

Work Order No.: **WOA2498-CM19**

Work Order Title: **CONSTRUCTION MANAGEMENT (CM) SERVICES FOR ORANGE LINE SIGNAL SYSTEM MODERNIZATION, PHASES 1 AND 2**

Attachment: **B**

Item	TASKS/WBS	TASKS/WBS Description	ODCs (See Attachment)	Davis, Chad	Davis, Chad	Jesse Gastelum	Jesse Gastelum	Oscar Noriega	Oscar Noriega	Total Hours	Totals
				Engineer, Supervising FY 23/24	Engineer, Supervising FY 24/25	Technical Expert Field Materials Tester FY 23/24	Technical Expert Field Materials Tester FY 24/25	Technical Expert Certified Welding Inspector FY 23/24	Technical Expert Certified Welding Inspector FY 24/25		
				\$ 262.65	\$ 269.74	\$ 201.58	\$ 207.02	\$ 201.58	\$207.02		
1	<b>TASK 1.0</b>	<b>PROJECT/WORK ORDER MANAGER</b>									
		PROJECT/WORK ORDER MANAGER								0	\$0.00
		Subtotals (Hours) =	N/A	0	0	0	0	0	0	0	\$0.00
		Subtotals (Costs) =	\$0.00	\$0.00	\$0.00	\$0.00	\$0.00	\$0.00	\$0.00	0	\$0.00
2	<b>TASK 2.0</b>	<b>PRE-CONSTRUCTION SERVICES</b>									
		PRE-CONSTRUCTION SERVICES								0	\$0.00
		Subtotals (Hours) =	N/A	0	0	0	0	0	0	0	\$0.00
		Subtotals (Costs) =	\$0.00	\$0.00	\$0.00	\$0.00	\$0.00	\$0.00	\$0.00	0	\$0.00
3	<b>TASK 3.0</b>	<b>CONSTRUCTION PHASE SERVICES</b>									
		CONSTRUCTION PHASE SERVICES	\$25,200.56	0	72	20	170		0	262	\$83,847.41
		Subtotals (Hours) =	N/A	0	72	20	170	0	0	262	\$83,847.41
		Subtotals (Costs) =	\$25,200.56	\$0.00	\$19,421.39	\$4,031.60	\$35,193.85	\$0.00	\$0.00	262	\$83,847.41
<b>Totals (Summary) =</b>										<b>262</b>	<b>\$83,847.41</b>
	Total (Hours) =	N/A	0	72	20	170	0	0	0	262	
	Total (Costs) =	\$25,200.56	\$0.00	\$19,421.39	\$4,031.60	\$35,193.85	\$0.00	\$0.00	\$0.00		\$83,847.41
	Percentage of Total (Hours) =		0%	27%	8%	65%	0%	0%	0%	100%	
	Percentage of Total (Costs) =	30%	0%	23%	5%	42%	0%	0%	0%		100%

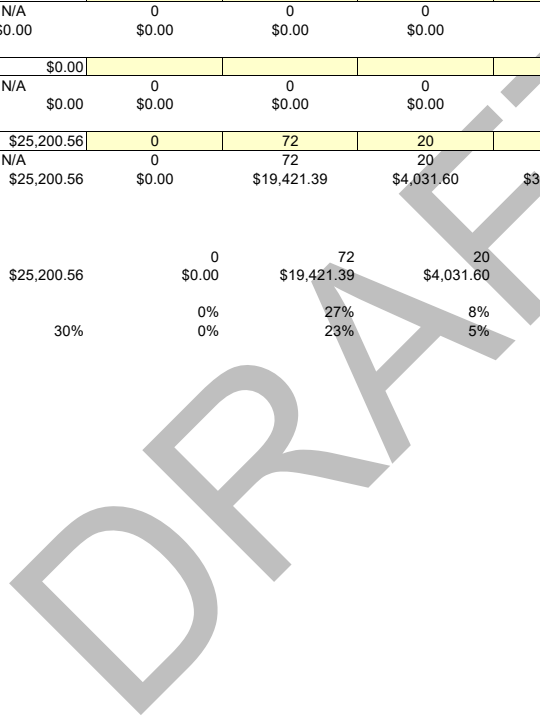

**Work Order Estimate Summary**

Consultant/ Subconsultant: **Kleinfelder**

Contract No: **G2498.0-21**

Task Order No. **WOA2498-CM19**

Work Order Title: **Iris Rapid Bus Stops and Transit Center East Construction Management Services**

Attachment: **B**

ODC Item	Description	Unit	Unit Cost	Task 1		Task 2		Task 3		Task 4		Task 5	
				Quantity	Total	Quantity	Total	Quantity	Total	Quantity	Total	Quantity	Total
1	Field Vehicle	Month	\$1,011.00					1.2	\$1,200.56				
2	Lab Testing	Estimate	\$24,000.00					1.0	\$24,000.00				
3													
4													
5													
6													
				Subtotal =		Subtotal =		Subtotal =	<b>\$25,200.56</b>	Subtotal =		Subtotal =	<b>\$25,200.56</b>

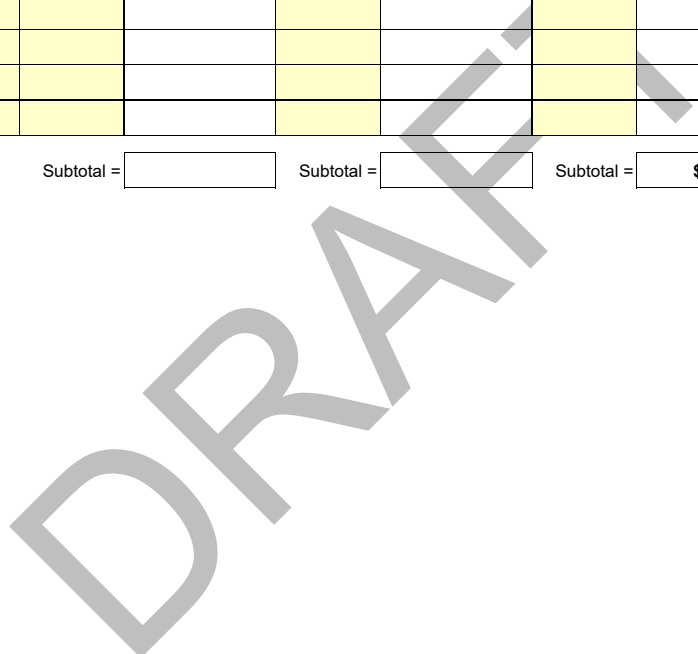

Total Hours = **510**  
 Total Costs = **\$97,823.63**

Consultant/Subconsultant: **C.A. Wehsener** MTS Doc. No.: **G2498.0-21**  
 Work Order No.: **WOA2498-CM19**  
 Work Order Title: **CONSTRUCTION MANAGEMENT (CM) SERVICES FOR ORANGE LINE SIGNAL SYSTEM MODERNIZATION, PHASES 1 AND 2** Attachment: **B**

Item	TASKS/WBS	TASKS/WBS Description	ODCs (See Attachment)	Wehsener, Chuck	Wehsener, Chuck	Wehsener, Tom	Wehsener, Tom	Total Hours	Totals	
				Engineer, Supervising FY 23/24	Engineer, Supervising FY 24/25	Electrical/Comms Inspector -PW Grp 2 FY 23/24	Electrical/Comms Inspector -PW Grp 2 FY 24/25			
1	<b>TASK 1.0</b>	<b>PROJECT/WORK ORDER MANAGER</b>								
		PROJECT/WORK ORDER MANAGER								
		Subtotals (Hours) =	N/A							
		Subtotals (Costs) =								
2	<b>TASK 2.0</b>	<b>PRE-CONSTRUCTION SERVICES</b>		20				20	\$4,592.20	
		PRE-CONSTRUCTION SERVICES		20				20	\$4,592.20	
		Subtotals (Hours) =	N/A	20				20	\$4,592.20	
		Subtotals (Costs) =		\$4,592.20				20	\$4,592.20	
3	<b>TASK 3.0</b>	<b>CONSTRUCTION PHASE SERVICES</b>		20	150	40	280	490	\$93,231.43	
		CONSTRUCTION PHASE SERVICES		20	150	40	280	490	\$93,231.43	
		Subtotals (Hours) =	N/A	20	150	40	280	490	\$93,231.43	
		Subtotals (Costs) =		\$4,592.20	\$35,371.42	\$6,504.80	\$46,763.01	490	\$93,231.43	
<b>Totals (Summary) =</b>									<b>510</b>	<b>\$97,823.63</b>
	Total (Hours) =	N/A		40	150	40	280	510		
	Total (Costs) =			\$9,184.40	\$35,371.42	\$6,504.80	\$46,763.01		\$97,823.63	
	Percentage of Total (Hours) =			8%	29%	8%	55%	100%		
	Percentage of Total (Costs) =			9%	36%	7%	48%		100%	

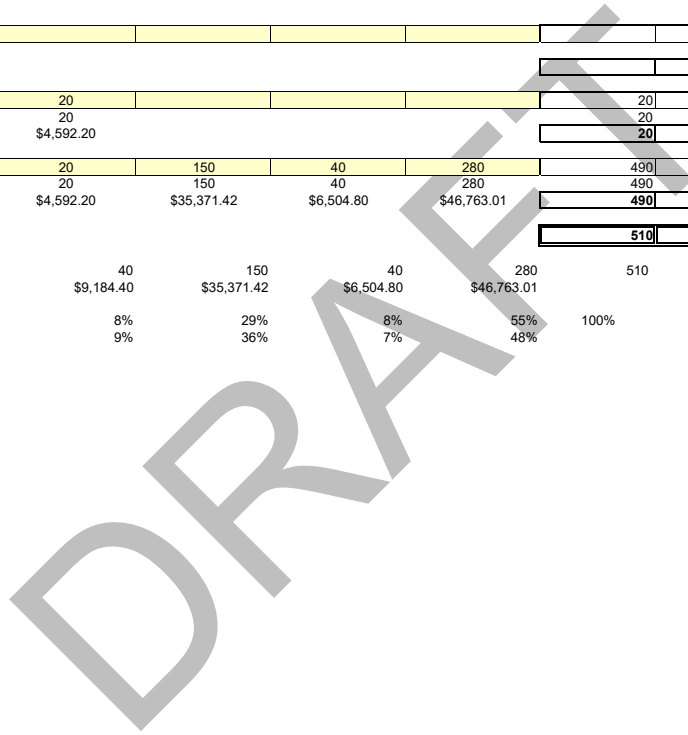

STATE OF CALIFORNIA - DEPARTMENT OF TRANSPORTATION

COST PROPOSAL  
 ON-CALL CONTRACT- OH & FEE ON DELTAS, WITH PREDETERMINED INCREASE DIRECT LABOR METHOD OF ACCOUNTING  
 ADM 2033 (Rev. 10/23/18)

Determination Number: SD-23-63-3-2021-1D  
 - Issue Date: August 22, 2021  
 - Effective Date: September 1, 2021  
 - Expiration Date: June 30, 2022

Consultant/Subconsultant Name: CAW  
 Agreement Number: G2498.0-21 Attachment 2  
 Date Prepared: 6/13/2023  
 Page No.: 1 of 1

**Loaded Billing Rate Calculations:**

**Non-Exempt Employee Loaded Billing Rates:**  
 A) Straight Time (ST) Loaded Billing Rate = [Actual Hourly Rate + ST Delta Base + ST Delta Fringe] \* [(1 + Field OH) \* (1 + Fee)]  
 B) ST Loaded Billing Rate + (1.5 Base PW Rate - ST Base PW Rate)\*[(1+Field OH) \* (1+Fee)] or ST Loaded Billing Rate + (2.0 Base PW Rate - 1.5 Base PW Rate) \*[(1+Field OH) \* (1+Fee)]

**Exempt Employee Loaded Billing Rates- Compensated for PW OT:**  
 C) Straight Time (ST) Loaded Billing Rate = [Actual Hourly Rate + ST Delta Base + ST Delta Fringe] \* [(1 + Field OH) \* (1 + Fee)]  
 D) ST Loaded Billing Rate + (1.5 Base PW Rate - ST Base PW Rate)\*[(1+Field OH) \* (1+Fee)] or ST Loaded Billing Rate + (2.0 Base PW Rate - 1.5 Base PW Rate) \*[(1+Field OH) \* (1+Fee)]

**The PW Deltas (Base & Fringe) above for Loaded Billing Rates, are applicable for services covered under DIR determinations. Includes Exempt employees who are normally not paid for OT worked, per company policy.**

**Exempt Employee Loaded Billing Rates- Not Compensated for OT (Uncompensated OT):**  
 E) ST Loaded Billing Rate = Actual Hourly Rate \* [(1 + Home OH) \* (1 + Fee)]  
 F) No Overtime. Columns are shaded out - See Stevie Ray Vaughn Non-Prevailing Wage example, line 59.

**Exempt Employee Loaded Billing Rates- Compensated for OT @ ST Rate:**  
 G) ST Loaded Billing Rate = Actual Hourly Rate \* [(1 + Home OH) \* (1 + Fee)]  
 H) ST Loaded Billing Rate + (1.5 x 0) or ST Loaded Billing Rate + (2.0 x 0) See example for Bob Marley, line 47 and Alecia Moore, line 65, both Non-Prevailing Wage Work.

<b>Home Office:</b>	<b>Fringe Benefit %</b>	<b>Overhead %</b>	<b>General Administration %</b>	<b>Combined %</b>
NORMAL				= 107.00%
OVERTIME				= 106.85%
<b>Field Office:</b>	<b>Fringe Benefit %</b>	<b>Overhead %</b>	<b>General Administration %</b>	<b>Combined %</b>
NORMAL				= 107.00%
OVERTIME				= 107.00%
<b>Project Specific:</b>	<b>Fringe Benefit %</b>	<b>Overhead %</b>	<b>General Administration %</b>	<b>Combined %</b>
NORMAL				= 107.00%
OVERTIME				= 107.00%

<b>FEE</b>	=	<b>8.50%</b>
<b>FCCM</b>	=	<b>0.10%</b>

Applicable Delta Base Multiplier (Field/Home)	=	<b>2.24595</b>
Applicable Delta Fringe Multiplier Fringe (Field)	=	<b>2.24595</b>

Name & Work Information	Home / Field / Project Specific Personnel	Prevailing Wage Rate established by State DIR (only applicable for prevailing wage work)						Employee Actual Rate (fringe benefits vary year over year)						Applicable DELTA (TOTAL) = Employee Total - DIR Total			Applicable DELTA Base = DIR Rate - Employee Base Rate			Applicable DELTA FRINGE = DELTA TOTAL - DELTA BASE (Employee - DIR)			Loaded Hourly Billing Rates			Effective Date of Hourly Rate [Add RFQ/RFP Advertisement Date]		% Escalation Increase	Actual Hourly Rate	Hourly Range for Class												
		Base Salary			Fringe Benefits	Total Base Salary + Fringe Benefit			Base Salary			Actual Fringe	Total = Base + Fringe			Straight			Straight			Straight			From	To																
		Straight	1.5 OT	2.0 OT		Straight	1.5 OT	2.0 OT	Straight	1.5 OT	2.0 OT		Straight	1.5 OT	2.0 OT	Straight	1.5 OT	2.0 OT	Straight	1.5 OT	2.0 OT	Straight	1.5 OT	2.0 OT																		
Thomas Wehsener - Building Inspection Group 2 PW	FIELD	\$52.21	\$78.32	\$104.42	\$30.04	\$82.25	\$108.36	\$134.46	\$72.41	\$108.61	\$144.81	\$30.79	\$103.20	\$139.40	\$175.60	\$0.00	\$0.00	\$0.00	\$0.00	\$0.00	\$0.00	\$0.00	\$0.00	\$0.00	\$0.00	\$0.00	\$0.00	\$0.00	\$0.00	\$0.00	\$0.00	\$0.00	7/1/2023	6/30/2024	2.70%	\$ 72.41	N/A					
4. Non-Exempt 5. Full Time	Prevailing Wage Work REG SHIFT	\$62.46	\$93.69	\$124.92	\$30.04	\$92.50	\$123.73	\$154.96	\$74.36	\$111.54	\$148.72	\$30.79	\$105.15	\$142.33	\$179.51	\$0.00	\$0.00	\$0.00	\$0.00	\$0.00	\$0.00	\$0.00	\$0.00	\$0.00	\$0.00	\$0.00	\$0.00	\$0.00	\$0.00	\$0.00	\$0.00	\$0.00	\$0.00	\$0.00	\$0.00	\$0.00	\$0.00	7/1/2024	6/30/2025	2.70%	\$ 74.36	N/A

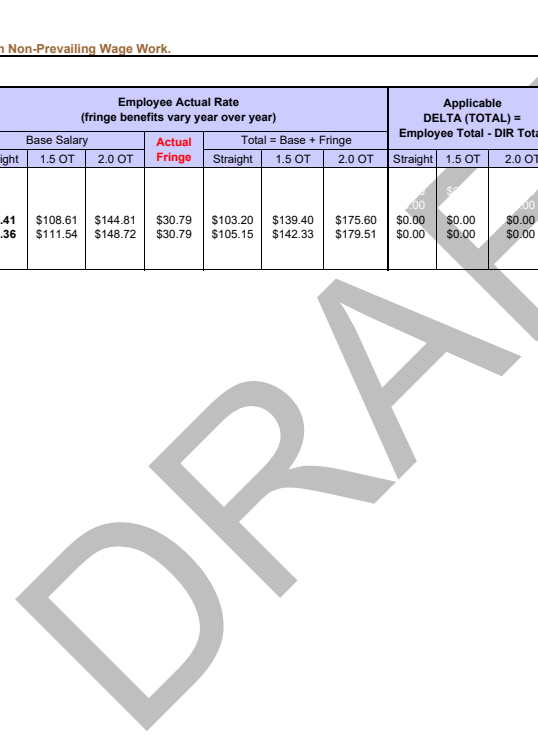

Total Hours = **212**  
 Total Costs = **\$41,298.99**

Consultant/Subconsultant: **ZT Consulting** MTS Doc. No.: **G2498.0-21**  
 Work Order Title: **CONSTRUCTION MANAGEMENT (CM) SERVICES FOR ORANGE LINE SIGNAL SYSTEM MODERNIZATION, PHASES 1 AND 2** Work Order No.: **WOA2498-CM19**  
 Attachment: **B**

Item	TASKS/WBS	TASKS/WBS Description	ODCs (See Attachment)	Farzad Tasbihgoo	Farzad Tasbihgoo	Andrew Soria	Andrew Soria	Total Hours	Totals
				Engineer, Senior	Engineer, Senior	Technical Expert Source/Welding Inspector	Technical Expert Source/Welding Inspector		
				FY 23/24	FY 24/25	FY 23/24	FY 24/25		
				\$ 192.26	\$ 197.45	\$ 192.26	\$ 197.45		

1	<b>TASK 1.0</b>	<b>PROJECT/WORK ORDER MANAGER</b>							
		PROJECT/WORK ORDER MANAGER						0	\$0.00
		Subtotals (Hours) =	N/A	0	0	0	0	0	\$0.00
		Subtotals (Costs) =	\$0.00	\$0.00	\$0.00	\$0.00	\$0.00	0	\$0.00
2	<b>TASK 2.0</b>	<b>PRE-CONSTRUCTION SERVICES</b>							
		PRE-CONSTRUCTION SERVICES		18				18	\$3,460.68
		Subtotals (Hours) =	N/A	18	0	0	0	18	\$3,460.68
		Subtotals (Costs) =	\$0.00	\$3,460.68	\$0.00	\$0.00	\$0.00	18	\$3,460.68
3	<b>TASK 3.0</b>	<b>CONSTRUCTION PHASE SERVICES</b>							
		CONSTRUCTION PHASE SERVICES		18	36	72	68	194	\$37,838.31
		Subtotals (Hours) =	N/A	18	36	72	68	194	\$37,838.31
		Subtotals (Costs) =	\$0.00	\$3,460.68	\$7,108.24	\$13,842.72	\$13,426.67	194	\$37,838.31
		<b>Totals (Summary) =</b>						<b>212</b>	<b>\$41,298.99</b>
		Total (Hours) =	N/A	36	36	72	68	212	
		Total (Costs) =	\$0.00	\$6,921.36	\$7,108.24	\$13,842.72	\$13,426.67		\$41,298.99
		Percentage of Total (Hours) =		17%	17%	34%	32%	100%	
		Percentage of Total (Costs) =	0%	17%	17%	34%	33%		100%

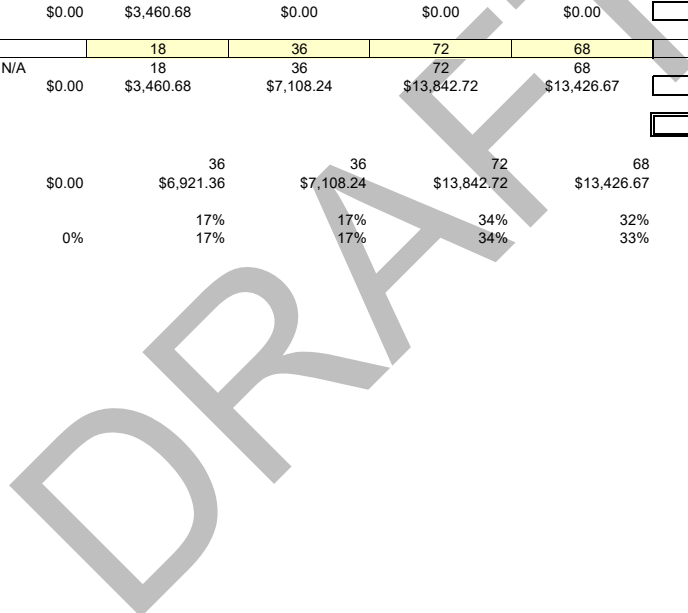

Total Hours = **296**  
 Total Costs = **\$84,864.74**

Consultant/Subconsultant: **TRC Engineers**

MTS Doc. No.: **G2498.0-21**

Work Order No.: **WOA2498-CM19**

Work Order Title: **CONSTRUCTION MANAGEMENT (CM) SERVICES FOR ORANGE LINE SIGNAL SYSTEM MODERNIZATION, PHASES 1 AND 2**

Attachment: **B**

ODCs (See Attachment)	Comte, Amy	Comte, Amy							Total Hours	Totals
	Storm Water, Technical Expert	Storm Water, Technical Expert								
	FY 23/24	FY 24/25								
	\$ 276.42	\$ 283.88								

Item TASKS/WBS TASKS/WBS Description

1	<b>TASK 1.0 PROJECT/WORK ORDER MANAGER</b>											
	PROJECT/WORK ORDER MANAGER											
	Subtotals (Hours) =	N/A	0	0	0	0	0	0	0	0	0	\$0.00
	Subtotals (Costs) =	\$0.00	\$0.00	\$0.00	\$0.00	\$0.00	\$0.00	\$0.00	\$0.00	\$0.00	0	\$0.00
2	<b>TASK 2.0 PRE-CONSTRUCTION SERVICES</b>											
	PRE-CONSTRUCTION SERVICES	\$141.94	32	0	0	0	0	0	0	0	32	\$8,987.38
	Subtotals (Hours) =	N/A	32	0	0	0	0	0	0	0	32	\$8,987.38
	Subtotals (Costs) =	\$141.94	\$8,845.44	\$0.00	\$0.00	\$0.00	\$0.00	\$0.00	\$0.00	\$0.00	32	\$8,987.38
3	<b>TASK 3.0 CONSTRUCTION PHASE SERVICES</b>											
	CONSTRUCTION PHASE SERVICES	\$1,170.99	32	232	0	0	0	0	0	0	264	\$75,877.36
	Subtotals (Hours) =	N/A	32	232	0	0	0	0	0	0	264	\$75,877.36
	Subtotals (Costs) =	\$1,170.99	\$8,845.44	\$65,860.93	\$0.00	\$0.00	\$0.00	\$0.00	\$0.00	\$0.00	264	\$75,877.36
<b>Totals (Summary) =</b>											<b>296</b>	<b>\$84,864.74</b>
	Total (Hours) =	N/A	64	232	0	0	0	0	0	0	296	
	Total (Costs) =	\$1,312.93	\$17,690.88	\$65,860.93	\$0.00	\$0.00	\$0.00	\$0.00	\$0.00	\$0.00		\$84,864.74
	Percentage of Total (Hours) =		22%	78%	0%	0%	0%	0%	0%	0%	100%	
	Percentage of Total (Costs) =	2%	21%	78%	0%	0%	0%	0%	0%	0%		100%

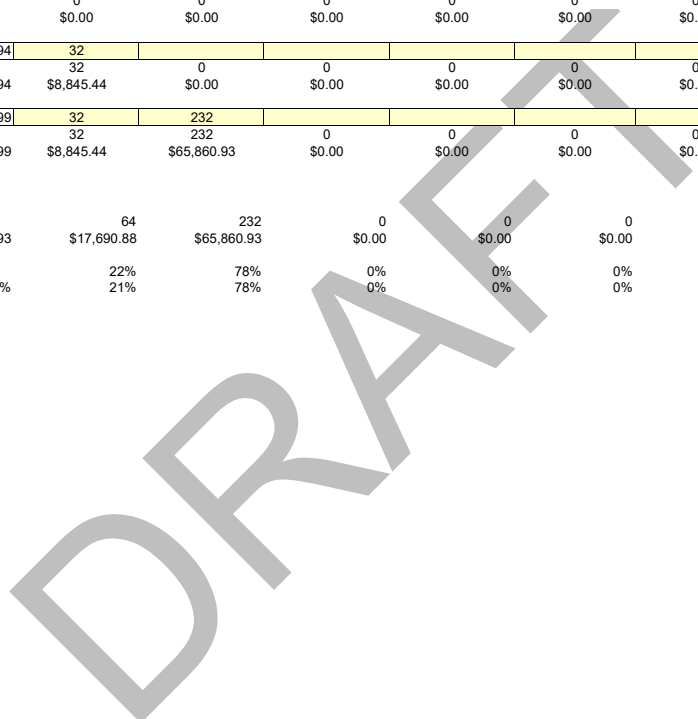

**Work Order Estimate  
Summary**

Consultant/ Subconsultant: **TRC Engineers**

Contract No: **G2498.0-21**

Task Order No. **WOA2498-CM19**

Work Order Title: **Iris Rapid Bus Stops and Transit Center East Construction Management Services**

Attachment: **B**

ODC Item	Description	Unit	Unit Cost	Task 1		Task 2		Task 3		Task 4		Task 5	
				Quantity	Total	Quantity	Total	Quantity	Total	Quantity	Total	Quantity	Total
1	Field Vehicle	Month	\$709.69			0.20	\$141.94	1.7	\$1,170.99				
2													
3													
4													
5													
6													
				Subtotal =		Subtotal =	<b>\$141.94</b>	Subtotal =	<b>\$1,170.99</b>	Subtotal =		Subtotal =	<b>\$1,312.93</b>

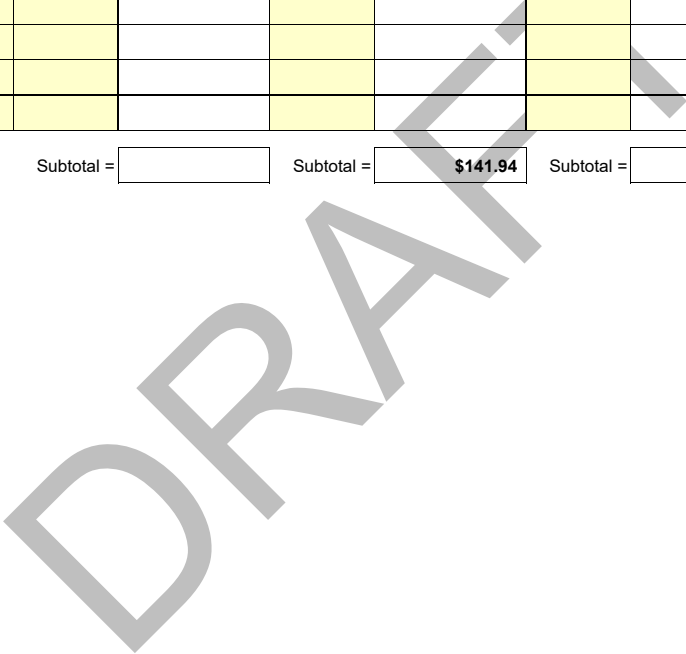

**KCS Employee Workplan**  
**MTS Contract/WO WOA2498-CM-11**  
**11 - MTS\_Iris Rapid Bus Stops and Transit Center East**

Year	Total
2024	\$ 760,532.03
2025	\$ 139,921.37
<b>Total</b>	<b>\$ 900,453.40</b>

Construction Cost \$ 5,483,171.00  
 CM Fee 17%

Totals By Firm	2024	2025	Total
CA Wehsener	\$ 84,068.91	\$ 13,754.71	\$ 97,823.63
ZTC	\$ 41,298.99	\$ -	\$ 41,298.99
TRC	\$ 73,331.99	\$ 11,532.76	\$ 84,864.74
Kleinfelder	\$ 72,124.29	\$ 11,723.11	\$ 83,847.40
KCS	\$ 489,764.58	\$ 102,910.79	\$ 592,675.37
<b>Total</b>	<b>\$ 760,588.76</b>	<b>\$ 139,921.37</b>	<b>\$ 900,510.13</b>

DRAFT



**Employee Workplan - projections**

Assume a May 2024 Project Start Date

Project Duration is 245 Calendar Days (1 Month Preconstruction, 8 Months Construction, 1 Month Closeout)

**MTS Contract/WO WOA2498-CM-11**

**11 - MTS\_Iris Rapid Bus Stops and Transit Center East**

				176	176	176	160	176	144	168	Total			
				May 24	Jun 24	Jul 24	Aug 24	Sep 24	Oct 24	Nov 24	Dec 24			
				Projections	Projections	Projections	Projections	Projections	Projections	Projections	Projections			
				PRECONSTRUCT	CONSTRUCTION									
		FY 23/24	FY24/25	Hours										
C.A. Wehsener	Wehsener, Chuck	Engineer, Supervising		Hours	20 hrs	20 hrs	20 hrs	20 hrs	20 hrs	20 hrs	20 hrs	20 hrs	160 hrs	
			\$ 229.61	\$ 235.81	Cost	\$4,592	\$4,592	\$4,716	\$4,716	\$4,716	\$4,716	\$4,716	\$4,716	\$37,482
	Wehsener, Tom	Electrical/Comms Inspector -PW Grp 2		Hours		40 hrs	40 hrs	40 hrs	40 hrs	40 hrs	40 hrs	40 hrs	40 hrs	\$280
			\$ 162.62	\$ 167.01	Cost		\$6,505	\$6,680	\$6,680	\$6,680	\$6,680	\$6,680	\$6,680	\$46,587
<b>Firm Total</b>					<b>\$4,592</b>	<b>\$11,097</b>	<b>\$11,397</b>	<b>\$11,397</b>	<b>\$11,397</b>	<b>\$11,397</b>	<b>\$11,397</b>	<b>\$11,397</b>	<b>\$84,069</b>	
ZT Consulting Group	Farzad Tasbihgoo	Engineer, Senior		Hours	18 hrs	18 hrs	18 hrs	18 hrs					72 hrs	
			\$ 192.26	\$ 197.45	Cost	\$3,461	\$3,461	\$3,554	\$3,554					\$14,030
	Andrew Soria	Technical Expert Source/Welding		Hours		72 hrs	68 hrs							140 hrs
			\$ 192.26	\$ 197.45	Cost		\$13,843	\$13,427						
<b>Firm Total</b>					<b>\$3,461</b>	<b>\$17,303</b>	<b>\$16,981</b>	<b>\$3,554</b>					<b>\$41,299</b>	
TRC Engineers	Comte, Amy	Storm Water, Technical Expert		Hours	32 hrs	32 hrs	32 hrs	32 hrs	32 hrs	32 hrs	32 hrs	32 hrs	256 hrs	
			\$ 276.42	\$ 283.88	Cost	\$8,845	\$8,845	\$9,084	\$9,084	\$9,084	\$9,084	\$9,084	\$9,084	\$72,196
			Truck-Month	\$142	\$142	\$142	\$142	\$142	\$142	\$142	\$142	\$142	\$1,136	
	<b>Firm Total</b>					<b>\$8,987</b>	<b>\$8,987</b>	<b>\$9,226</b>	<b>\$9,226</b>	<b>\$9,226</b>	<b>\$9,226</b>	<b>\$9,226</b>	<b>\$9,226</b>	<b>\$73,332</b>
Kleinfelder	Davis, Chad	Engineer, Supervising		Hours		8 hrs	8 hrs	8 hrs	8 hrs	8 hrs	8 hrs	8 hrs	56 hrs	
			\$ 262.65	\$ 269.74	Cost		\$2,101	\$2,158	\$2,158	\$2,158	\$2,158	\$2,158	\$2,158	\$15,106
	Jesse Gastelum	Technical Expert Field Materials Tester		Hours		20 hrs	20 hrs	40 hrs	30 hrs	20 hrs	20 hrs	20 hrs	170 hrs	
			\$ 201.58	\$ 207.02	Cost		\$4,032	\$4,140	\$8,281	\$6,211	\$4,140	\$4,140	\$4,140	\$35,085
	Oscar Noriega	Technical Expert Certified Welding Inspector		Hours										
			\$ 201.58	\$ 207.02	Cost									
				Truck-Month		\$133	\$133	\$133	\$133	\$133	\$133	\$133	\$934	
<b>Firm Total</b>					<b>\$9,266</b>	<b>\$9,432</b>	<b>\$13,572</b>	<b>\$11,502</b>	<b>\$9,432</b>	<b>\$9,432</b>	<b>\$9,432</b>	<b>\$72,124</b>		
Kleinfelder - Construction Services	Beringhaus, Michalle	Task Order Manager		Hours	2 hrs	2 hrs	2 hrs	2 hrs	2 hrs	2 hrs	2 hrs	2 hrs	16 hrs	
			\$ 214.15	\$ 219.93	Cost	\$428	\$428	\$440	\$440	\$440	\$440	\$440	\$440	\$3,496
	Berrios, Jesus	Project Controls III		Hours	2 hrs	2 hrs	2 hrs	2 hrs	2 hrs	2 hrs	2 hrs	2 hrs	16 hrs	
			\$ 153.18	\$ 157.32	Cost	\$306	\$306	\$315	\$315	\$315	\$315	\$315	\$315	\$2,501
	Stewart, Shawn	Civil Inspector- PW Grp 2		Hours	40 hrs	176 hrs	176 hrs	176 hrs	160 hrs	176 hrs	144 hrs	168 hrs	1,216 hrs	
			\$164.11	\$ 168.54	Cost	\$6,564	\$28,883	\$29,663	\$29,663	\$26,966	\$29,663	\$24,270	\$28,314	\$203,986
			\$ 1,377.00		Truck-Month	\$344	\$1,515	\$1,515	\$1,515	\$1,377	\$1,515	\$1,239	\$1,446	\$10,465
	Gentile, Hank	Contract Manager		Hours	8 hrs	8 hrs	8 hrs	8 hrs	8 hrs	8 hrs	8 hrs	8 hrs	8 hrs	64 hrs
			\$ 291.01	\$ 298.87	Cost	\$2,328	\$2,328	\$2,391	\$2,391	\$2,391	\$2,391	\$2,391	\$2,391	\$19,002
			Truck-Month	\$69	\$69	\$69	\$69	\$69	\$69	\$69	\$69	\$69	\$69	\$551
	Mustafa, Hassan	Engineer, Supervising		Hours	40 hrs	88 hrs	88 hrs	88 hrs	80 hrs	88 hrs	72 hrs	84 hrs	628 hrs	
			\$ 237.94	\$ 244.36	Cost	\$9,518	\$20,939	\$21,504	\$21,504	\$19,549	\$21,504	\$17,594	\$20,527	\$152,639
\$ 1,377.00				Truck-Month	\$344	\$757	\$757	\$757	\$689	\$757	\$620	\$723	\$5,405	
Chow, Vivian	Engineer II		Hours	40 hrs	40 hrs	40 hrs	40 hrs	40 hrs	40 hrs	40 hrs	40 hrs	40 hrs	320 hrs	
		\$ 149.90	\$ 153.95	Cost	\$5,996	\$5,996	\$6,158	\$6,158	\$6,158	\$6,158	\$6,158	\$6,158	\$48,939	
Plotnikiewicz, Mark	Scheduler, Technical Expert		Hours	40 hrs	40 hrs	16 hrs	16 hrs	16 hrs	16 hrs	16 hrs	16 hrs	16 hrs	176 hrs	
		\$ 231.07	\$ 237.31	Cost	\$9,243	\$9,243	\$3,797	\$3,797	\$3,797	\$3,797	\$3,797	\$3,797	\$41,267	
		\$ 1,377.00		Truck-Month	\$344	\$344	\$138	\$138	\$138	\$138	\$138	\$138	\$1,515	
<b>Firm Total</b>					<b>\$35,485</b>	<b>\$70,808</b>	<b>\$66,746</b>	<b>\$66,746</b>	<b>\$61,888</b>	<b>\$66,746</b>	<b>\$57,030</b>	<b>\$64,317</b>	<b>\$489,765</b>	
Contract Total				Hours	242 hrs	566 hrs	538 hrs	490 hrs	438 hrs	452 hrs	404 hrs	440 hrs	3,570 hrs	
				Cost	\$51,282	\$111,502	\$108,027	\$98,741	\$88,465	\$91,046	\$81,743	\$88,721	\$719,527	
				Truck-Month	\$1,244	\$2,960	\$2,754	\$2,754	\$2,547	\$2,754	\$2,341	\$2,651	\$20,005	
				Lab Tests		\$3,000	\$3,000	\$3,000	\$3,000	\$3,000	\$3,000	\$3,000	\$21,000	
	<b>Contract Total</b>					<b>\$52,525</b>	<b>\$117,462</b>	<b>\$113,781</b>	<b>\$104,495</b>	<b>\$94,012</b>	<b>\$96,800</b>	<b>\$87,084</b>	<b>\$94,371</b>	<b>\$760,532</b>

**Employee Workplan - projections**

**MTS Contract/WO WOA2498-CM-11  
11 - MTS\_Iris Rapid Bus Stops and Transit Center East**

					168	144	Total	
					Jan 25	Feb 25		
					Projections	Projections		
					CONSTRUCTION	CLOSEOUT		
		FY24/25	FY25/26					
C.A. Wehsener	Wehsener, Chuck	Engineer, Supervising			Hours	20 hrs	10 hrs	30 hrs
			\$ 235.81	\$ 242.18	Cost	\$4,716	\$2,358	\$7,074
	Wehsener, Tom	Electrical/Comms Inspector -PW Grp 2			Hours	40 hrs		\$40
			\$ 167.01	\$ 171.52	Cost	\$6,680		\$6,680
<b>Firm Total</b>					<b>\$11,397</b>	<b>\$2,358</b>	<b>\$13,755</b>	
ZT Consulting Group	Farzad Tasbihgoo	Engineer, Senior			Hours			
			\$ 197.45	\$ 202.78	Cost			
	Andrew Soria	Technical Expert Source/Welding			Hours			
			\$ 197.45	\$ 202.78	Cost			
<b>Firm Total</b>								
TRC Engineers	Comte, Amy	Storm Water, Technical Expert			Hours	32 hrs	8 hrs	40 hrs
			\$ 283.88	\$ 291.55	Cost	\$9,084	\$2,271	\$11,355
			\$ 709.69		Truck-Month	\$142	\$35	\$177
			<b>Firm Total</b>					<b>\$9,226</b>
Kleinfelder	Davis, Chad	Engineer, Supervising			Hours	8 hrs	8 hrs	16 hrs
			\$ 269.74	\$ 277.02	Cost	\$2,158	\$2,158	\$4,316
	Jesse Gastelum	Technical Expert Field Materials			Hours	20 hrs		20 hrs
			\$ 207.02	\$ 212.61	Cost	\$4,140		\$4,140
	Oscar Noriega	Technical Expert Certified Welding Inspector			Hours			
			\$ 207.02	\$ 212.61	Cost			
					Truck-Month	\$133	\$133	\$267
					Lab Tests	\$3,000		\$3,000
<b>Firm Total</b>					<b>\$9,432</b>	<b>\$2,291</b>	<b>\$11,723</b>	
Kleinfelder - Construction Services	Beringhaus, Michalle	Task Order Manager			Hours	2 hrs	2 hrs	4 hrs
			\$ 219.93	\$ 225.87	Cost	\$440	\$440	\$880
	Berrios, Jesus	Project Controls II			Hours	2 hrs	2 hrs	4 hrs
			\$ 157.32	\$ 161.56	Cost	\$315	\$315	\$629
	Stewart, Shawn	Construction Inspector II			Hours	168 hrs	40 hrs	208 hrs
			\$ 168.54	\$ 173.09	Cost	\$28,314	\$6,742	\$35,056
			\$ 1,377.00		Truck-Month	\$1,377	\$344	\$1,721
	Gentile, Hank	Principal			Hours	8 hrs	8 hrs	16 hrs
			\$ 298.87	\$ 306.94	Cost	\$2,391	\$2,391	\$4,782
			\$ 1,377.00		Truck-Month	\$69	\$69	\$138
	Mustafa, Hassan	ARE			Hours	84 hrs	80 hrs	164 hrs
			\$ 244.36	\$ 250.96	Cost	\$20,527	\$19,549	\$40,076
			\$ 1,377.00		Truck-Month	\$723	\$689	\$1,411
	Chow, Vivian	Engineer II			Hours	40 hrs	40 hrs	80 hrs
\$ 153.95			\$ 158.10	Cost	\$6,158	\$6,158	\$12,316	
Plotnikiewicz, Mark	Schedule Engineer			Hours	16 hrs	8 hrs	24 hrs	
		\$ 237.31	\$ 243.72	Cost	\$3,797	\$1,898	\$5,695	
		\$ 1,377.00		Truck-Month	\$138	\$69	\$207	
<b>Firm Total</b>					<b>\$64,248</b>	<b>\$38,663</b>	<b>\$102,911</b>	
Contract Total					Hours	440 hrs	206 hrs	646 hrs
					Cost	\$88,721	\$44,280	\$133,000
					Truck-Month	\$2,582	\$1,339	\$3,921
					Lab Tests	\$3,000		\$3,000
	<b>Contract Total</b>					<b>\$94,302</b>	<b>\$45,619</b>	<b>\$139,921</b>



**Metropolitan  
Transit  
System**

**DRAFT FOR EXECUTIVE COMMITTEE REVIEW DATE: 4/11/2024**

## **Agenda Item No. 16**

MEETING OF THE SAN DIEGO METROPOLITAN TRANSIT SYSTEM  
BOARD OF DIRECTORS

April 25, 2024

**SUBJECT:**

Building B Office Improvements – Work Order Agreement

**RECOMMENDATION:**

That the San Diego Metropolitan System (MTS) Board of Directors authorize the Chief Executive Officer (CEO) to execute Work Order No. MTSJOC324-48 under Job Order Contract (JOC) to MTS Doc. No. PWG324.0-21 (in substantially the same format as Attachment A), with ABC General Contractor, Inc. (ABCGC), in the amount of \$220,792.67 for the improvements of Revenue Area, Pay Station Service Room, Facility Offices and Break Room areas at Building B.

**Budget Impact**

The total cost for this work order is estimated to be \$220,792.67. Under separate MTS Doc No. L1282.0-16 with The Gordian Group, MTS will pay a 1.76% JOC software license fee in the amount of \$3,885.95. The project will be funded by the San Diego Trolley, Inc. (SDTI) Facilities Operating Budget account 380016-571142.

**DISCUSSION:**

MTS owns the building located at 1341 Commercial Street, commonly referred to by staff as “Building B”. Building B houses San Diego Trolley Inc’s Facilities, Revenue, and Stores functions. The existing offices in Building B are in poor condition and require rehabilitation and updating. This includes carpet replacement, new paint, upgrades for electrical lighting, and new cabinets to increase storage.

This work will be completed by issuing a JOC work order to MTS’s JOC contractor for general building and facilities construction services. JOC is a procurement method under which public agencies may accomplish frequently encountered repairs, maintenance, and construction projects through a single, competitively procured long-term agreement.

The JOC program includes a catalogue of pricing for a variety of potential tasks to be performed under the contract that have been pre-priced by the contractor, The Gordian Group. All potential contractors are subject to the pricing within this catalogue. Each contractor then includes an



adjustment factor, escalating their proposed price from the catalogue price, to determine the total cost of the task order. The adjustment factor represents an average percentage increase over the catalogue price (i.e. 1.25 adjustment factor represents 25% above the catalogue price) for that respective task within the project. In order to select the lowest responsive and responsible bidder, MTS staff compares each contractor's proposed adjustment factor.

On April 12, 2019, MTS issued an Invitation for Bids (IFB) seeking a contractor to provide on-call JOC General Civil Construction services that primarily consists of repair, remodeling, or other repetitive work for general civil and site improvements, including earthwork, utilities, paving, concrete, drainage, landscaping mitigation, site clearing, and all required incidental professional and technical services.

Three (3) bids were received, and MTS determined that ABCGC was the lowest responsive and responsible bidder. On June 13, 2019 (Agenda Item (AI) 12), the MTS Board of Directors authorized the CEO to execute MTS Doc. No. PWG347.0-22 with ABCGC for Civil Construction Services. Today's work order would be issued under this master agreement.

Today's proposed action would issue a work order to ABCGC under their JOC General Civil Construction master agreement to provide all materials, labor, and equipment for the Building B Office Improvements. Pricing for this repair work order was reviewed and determined to be fair and reasonable. Work is expected to be completed within ninety (90) days of issuance of the notice to proceed. ABCGC will be utilizing A&S Flooring Inc., Swift Electric, and Harborside Construction Inc., as subcontractors for this work order.

Therefore, staff recommends that the MTS Board of Directors authorize the CEO to execute Work Order MTSJOC324-48 under JOC to MTS Doc. No. PWG324.0-21 (in substantially the same format as Attachment A), with ABCGC, in the amount of \$220,792.67 for the improvements of offices in Building B.

/s/ Sharon Cooney  
Sharon Cooney  
Chief Executive Officer

Key Staff Contact: Julia Tuer, 619.557.4515, [Julia.Tuer@sdmts.com](mailto:Julia.Tuer@sdmts.com)

Attachment: A. Draft Job Order MTS Doc No. MTSJOC324-48



# Metropolitan Transit System

## JOB ORDER CONTRACT WORK ORDER

PWG324.0-21  
CONTRACT NUMBER

MTSJOC324-48  
WORK ORDER NUMBER

THIS AGREEMENT is entered into this \_\_\_\_\_ day of \_\_\_\_\_ 2024, in the state of California by and between San Diego Metropolitan Transit System ("MTS"), a California public agency, and the following, hereinafter referred to as "Contractor":

Name: ABC General Contractor, Inc. Address: 3120 National Avenue

Form of Business: Corporation San Diego, CA 92113  
(Corporation, partnership, sole proprietor, etc.)

Telephone: (619) 247-7113

Authorized person to sign contracts: Travis Brozowski President  
Name Title

Pursuant to the existing Job Order Contract (MTS Doc. No. PWG324.0-21), MTS issues a Work Order to Contractor to complete the detailed Scope of Work (attached as Exhibit A.), the Cost Breakdown for the Scope of Work (attached as Exhibit B.), and the subcontractor listing form applicable to this Work Order (attached as Exhibit C.)

TOTAL PAYMENTS TO CONTRACTOR SHALL NOT EXCEED \$220,792.67

SAN DIEGO METROPOLITAN TRANSIT SYSTEM

ABC GENERAL CONTRACTOR, INC.

By: \_\_\_\_\_  
Sharon Cooney, Chief Executive Officer

Firm: \_\_\_\_\_

Approved as to form:

By: \_\_\_\_\_  
Signature

By: \_\_\_\_\_  
Karen Landers, General Counsel

Title: \_\_\_\_\_



EXHIBIT A  
(Scope of Work)



# San Diego Metropolitan Transit System

1255 Imperial Ave  
San Diego, California 92101

## Final Scope of Work

Date: 3/13/2024

**Job Order Contracting**

**To:** \_\_\_\_\_ **From:** \_\_\_\_\_

**Contract No:** PWG324.0-21

**Job Order No:** MTSJOC324-48

**Job Order Title:** Building B Offices Improvements

**Location:** Building B  
1341 Commercial Street  
San Diego, CA 92101

**Brief Scope of Work:** Rehabilitation of Offices in Building B.

The following items detail the scope of work as discussed at the site. All requirements necessary to accomplish the items set forth below shall be considered part of this scope of work.

## DETAILED SCOPE OF WORK

The Contractor shall complete the construction of this project in its entirety and shall provide all labor, materials, equipment, procuring all materials and performing all other work necessary to complete the work in accordance with the Detailed Scope of Work along with Conformed Special Provisions.

This work consists of **Building B Offices Improvements**

### I. SCOPE OF WORK - The contractor shall:

- See attached detailed - Appendix A

### II. SUBMITTALS:

- Paints
- Carpet
- Steel Counting Table
- Storage Cabinet
- Layout
- Schedule

### **III. STAGING:**

- It is the Contractor's responsibility to keep and store all materials and equipment within the work area as possible. Any further staging would have to be coordinated with the MTS Project Manager. All property stored onsite is the responsibility of the contractor and MTS shall not be held liable for any and all equipment, material, tools, etc.

### **IV. EXISTING UTILITIES:**

- The contractor shall notify the Engineer and Underground Service Alert (USA) (800) 422-4133 (if applicable) at least two working days, but not more than 14 calendar days, prior to performing any excavation or other work close to any underground pipeline, conduit, wire or other structure.
- Contractor is to locate and protect in-place all existing underground facilities. The contractor shall coordinate with MTS personnel in order to have said facilities located and marked out by Cable, Pipe & Leak Detection (CPL) (619) 660-0844, or other approved utility locating subcontractor familiar with MTS facilities. All coordination and costs associated with (CPL) shall be provided by the contractor. If the Contractor cannot protect in-place existing underground facilities, the Contractor shall replace any damaged or removed underground facilities in a timely manner as to not allow for extended delays to the trolley services. If the services are subject to extended delays, the contractor shall notify MTS prior to the expiring of the original scheduled work time.
- Where such facilities are not located on the plans, no work shall be performed near said facilities until the owner, or his representative, has located the facility by potholing, probing, or other means that locate and identify the facility.

### **V. CONSTRUCTION SURVEYING:**

- All field construction surveying required for accurate horizontal and vertical location, and other various items of work on the contract shall be furnished by the Contractor. For the elevation, slope, and location should generally be based on what is existing.

### **VI. TEMP FACILITIES:**

- Contractor is responsible for temp power and water if there is not a close or local source.

### **VII. SAFETY AND ACCESS:**

- All work will occur within during the weekend hours and Single-Tracking, and so caution must be taken around. Cover protection for construction might require. RWP Training is required.

### **VIII. WASTE:**

- The contractor is responsible for legally disposing of any and all waste in relation to the work. The



contractor shall not use any onsite receptacles to dispose of material generated during the performance of this contract. Contractor is responsible for general cleanup at the end of each work day.

**IX.SCHEDULE:**

- All work shall be completed as soon as possible within 90 calendar days from issuance of NTP.

All job orders include the labor, equipment, and material costs for a complete and in-place installation, unless otherwise noted.

EXHIBIT B  
(Cost Breakdown)

# Price Proposal Detail Report

## By Division

Version: 2.0

Approved

Proposal Value: \$220,792.67

Approved Date: March 12, 2024

Job Order: MTSJOC324-48

Job Order Name: Building B Offices Improvements

Location: Building B 1341 Commercial Street San Diego, CA 92101

Contractor: ABC General Inc.

Contract Number: PWG324.0-21

Contract Name: JOC Building and Facilities Construction Services. - Option 3

Division		Install Total	NPP Total	Demo Total	Division Total
01	General Requirements	\$2,900.12	\$0.00	\$0.00	\$2,900.12
03	Concrete	\$23,877.24	\$0.00	\$0.00	\$23,877.24
05	Metals	\$5,397.76	\$0.00	\$0.00	\$5,397.76
09	Finishes	\$82,477.53	\$0.00	\$10,804.87	\$93,282.40
10	Specialties	\$18,407.67	\$0.00	\$3,352.58	\$21,760.25
11	Equipment	\$34,902.63	\$0.00	\$0.00	\$34,902.63
12	Furnishings	\$16,821.77	\$0.00	\$0.00	\$16,821.77
26	Electrical	\$20,838.96	\$0.00	\$1,011.54	\$21,850.50
<b>Line Count: 43</b>				<b>Proposal Total:</b>	<b>\$220,792.67</b>

The Percentage of Non Pre-Priced on this Proposal: 0.0%

\* Includes Price Changes due to Construction Task Catalog update

# Price Proposal Detail Report

## By Division

Version: 2.0

Approved

Proposal Value: \$220,792.67

Approved Date: March 12, 2024

Job Order: MTSJOC324-48

Job Order Name: Building B Offices Improvements

Location: Building B 1341 Commercial Street San Diego, CA 92101

Contractor: ABC General Inc.

Contract Number: PWG324.0-21

Contract Name: JOC Building and Facilities Construction Services. - Option 3

**01 General Requirements** **\$2,900.12**

Record #	CSI Number	Description	Type	Quantity	Unit Price	UOM	Factor	Line Total
1	012220000010	Electrician	Installation	32.00	\$78.27	HR	1.1579	\$2,900.12
<b>Accepted</b>		<i>History: 1.1 Added, 1.2 Accepted, 1.3 Accepted, 2.0 Accepted</i>	<b>Demo:</b>	0.000000	\$0.00	HR	1.1579	\$0.00
<b>Includes Labor Yes Includes Equipment No Includes Materials No</b>								

**User Note:** Time to trace circuits in warehouse and break the leg for rear room, 2 men one day

**Item Note:** For tasks not included in the Construction Task Catalog® and as directed by owner only.

**Total: \$2,900.12**

**03 Concrete** **\$23,877.24**

Record #	CSI Number	Description	Type	Quantity	Unit Price	UOM	Factor	Line Total
2	030130710027	Up To 1/4" Wide, Latex Emulsion, Gravity Fed Non Structural Crack Repair For Concrete, Surface Applied With Squeeze Tube (Quikrete® Concrete Crack Seal)	Installation	344.00	\$5.33	LF	1.1579	\$2,123.03
<b>Accepted</b>		<i>History: 1.1 Added, 1.2 Accepted, 1.3 Accepted, 2.0 Accepted</i>	<b>Demo:</b>	0.000000	\$0.00	LF	1.1579	\$0.00
<b>Includes Labor Yes Includes Equipment Yes Includes Materials Yes</b>								

**User Note:** Warehouse, Estimated 20% repair prior to seal

**Item Note:**

**Total: \$2,123.03**

\* Includes Price Changes due to Construction Task Catalog update

# Price Proposal Detail Report

## By Division

Version: 2.0

Approved

Proposal Value: \$220,792.67

Approved Date: March 12, 2024

Job Order: MTSJOC324-48

Job Order Name: Building B Offices Improvements

Location: Building B 1341 Commercial Street San Diego, CA 92101

Contractor: ABC General Inc.

Contract Number: PWG324.0-21

Contract Name: JOC Building and Facilities Construction Services. - Option 3

3	033543000002	Mechanically Grind Concrete Floor With 40 Grit Metal Bonded Diamond Wheels	Installation	1,785.00	\$1.52	SF	1.1579	\$3,141.61
Accepted		<i>History: 1.1 Added, 1.2 Modified, 1.3 Modified, 2.0 Accepted</i>	Demo:	0.000000	\$0.00	SF	1.1579	\$0.00

Includes Labor Yes Includes Equipment Yes Includes Materials No

Owner Comments: V:1.2-warehouse floor area = 1,560sqft

User Note: Warehouse Prep  
 Warehouse is 35x51-less Sup Off (140SF) plus area outside in front of staff restroom for a total of 1,785SF

Item Note:

<b>Total:</b>	<b>\$3,141.61</b>
---------------	-------------------

4	033543000002	For Up To 500, Add	<b>MOD: 0162</b>	Installation	140.00	\$2.95	SF	1.1579	\$478.21
Accepted		<i>History: 1.1 Added, 1.2 Modified, 1.3 Modified, 2.0 Accepted</i>							

Includes Labor Yes Includes Equipment Yes Includes Materials No

User Note: Area outside warehouse in front of restroom

Item Note:

<b>Total:</b>	<b>\$478.21</b>
---------------	-----------------

5	033543000002	For >1,000 To 2,500, Add	<b>MOD: 0164</b>	Installation	1,645.00	\$1.81	SF	1.1579	\$3,447.59
Accepted		<i>History: 1.1 Added, 1.2 Modified, 1.3 Modified, 2.0 Accepted</i>							

Includes Labor Yes Includes Equipment Yes Includes Materials No

User Note: Warehouse (no Sup Off)

Item Note:

<b>Total:</b>	<b>\$3,447.59</b>
---------------	-------------------

\* Includes Price Changes due to Construction Task Catalog update

# Price Proposal Detail Report

## By Division

Version: 2.0

Approved

Proposal Value: \$220,792.67

Approved Date: March 12, 2024

Job Order: MTSJOC324-48

Job Order Name: Building B Offices Improvements

Location: Building B 1341 Commercial Street San Diego, CA 92101

Contractor: ABC General Inc.

Contract Number: PWG324.0-21

Contract Name: JOC Building and Facilities Construction Services. - Option 3

6	033543000003	Mechanically Grind Concrete Floor With 80 Grit Metal Bonded Diamond Wheels	Installation	1,785.00	\$1.21	SF	1.1579	\$2,500.89
Accepted		<i>History: 1.1 Added, 1.2 Modified, 1.3 Modified, 2.0 Accepted</i>	Demo:	0.000000	\$0.00	SF	1.1579	\$0.00

Includes Labor Yes Includes Equipment Yes Includes Materials No

Owner Comments: V:1.2-warehouse floor area = 1,560sqft

User Note: Warehouse Prep  
 Warehouse is 35x51-less Sup Off (140SF) plus area outside in front of staff restroom for a total of 1,785SF

Item Note:

Total:	\$2,500.89
--------	------------

7	033543000003	For Up To 500, Add	MOD: 0162	Installation	140.00	\$2.35	SF	1.1579	\$380.95
Accepted		<i>History: 1.1 Added, 1.2 Modified, 1.3 Modified, 2.0 Accepted</i>							

Includes Labor Yes Includes Equipment Yes Includes Materials No

User Note: Area outside Warehouse in front of Staff restroom

Item Note:

Total:	\$380.95
--------	----------

8	033543000003	For >1,000 To 2,500, Add	MOD: 0164	Installation	1,645.00	\$1.44	SF	1.1579	\$2,742.83
Accepted		<i>History: 1.1 Added, 1.2 Modified, 1.3 Modified, 2.0 Accepted</i>							

Includes Labor Yes Includes Equipment Yes Includes Materials No

User Note: Warehouse area less Sup Off

Item Note:

Total:	\$2,742.83
--------	------------

\* Includes Price Changes due to Construction Task Catalog update

# Price Proposal Detail Report

## By Division

Version: 2.0

Approved

Proposal Value: \$220,792.67

Approved Date: March 12, 2024

Job Order: MTSJOC324-48

Job Order Name: Building B Offices Improvements

Location: Building B 1341 Commercial Street San Diego, CA 92101

Contractor: ABC General Inc.

Contract Number: PWG324.0-21

Contract Name: JOC Building and Facilities Construction Services. - Option 3

9	033543000004	Mechanically Grind Concrete Floor With 100 Grit Resin Bonded Diamond Wheels	Installation	1,785.00	\$1.01	SF	1.1579	\$2,087.52
Accepted		<i>History: 1.1 Added, 1.2 Modified, 1.3 Modified, 2.0 Accepted</i>	Demo:	0.000000	\$0.00	SF	1.1579	\$0.00

Includes Labor Yes Includes Equipment Yes Includes Materials No

Owner Comments: V:1.2-warehouse floor area = 1,560sqft

User Note: Warehouse Prep  
 Warehouse is 35x51-less Sup Off (140SF) plus area outside in front of staff restroom for a total of 1,785SF

Item Note:

Total:	\$2,087.52
--------	------------

10	033543000004	For Up To 500, Add	MOD: 0162	Installation	140.00	\$1.96	SF	1.1579	\$317.73
Accepted		<i>History: 1.1 Added, 1.2 Modified, 1.3 Modified, 2.0 Accepted</i>							

Includes Labor Yes Includes Equipment Yes Includes Materials No

User Note: Area outside of Warehouse in front of restroom

Item Note:

Total:	\$317.73
--------	----------

11	033543000004	For >1,000 To 2,500, Add	MOD: 0164	Installation	1,645.00	\$1.21	SF	1.1579	\$2,304.74
Accepted		<i>History: 1.1 Added, 1.2 Modified, 1.3 Modified, 2.0 Accepted</i>							

Includes Labor Yes Includes Equipment Yes Includes Materials No

User Note: Warehouse less Sup Off

Item Note:

Total:	\$2,304.74
--------	------------

\* Includes Price Changes due to Construction Task Catalog update

# Price Proposal Detail Report

## By Division

Version: 2.0

Approved

Proposal Value: \$220,792.67

Approved Date: March 12, 2024

Job Order: MTSJOC324-48

Job Order Name: Building B Offices Improvements

Location: Building B 1341 Commercial Street San Diego, CA 92101

Contractor: ABC General Inc.

Contract Number: PWG324.0-21

Contract Name: JOC Building and Facilities Construction Services. - Option 3

12	033543000005	Mechanically Grind Concrete Floor With 150 Grit Metal Bonded Diamond Wheels	Installation	1,785.00	\$0.94	SF	1.1579	\$1,942.84
Accepted		<i>History: 1.1 Added, 1.2 Modified, 1.3 Modified, 2.0 Accepted</i>	Demo:	0.000000	\$0.00	SF	1.1579	\$0.00

Includes Labor Yes Includes Equipment Yes Includes Materials No

Owner Comments: V:1.2-warehouse floor area = 1,560sqft

User Note: Warehouse Prep  
Warehouse is 35x51-less Sup Off (140SF) plus area outside in front of staff restroom for a total of 1,785SF

Item Note:

<b>Total:</b>	<b>\$1,942.84</b>
---------------	-------------------

13	033543000005	For Up To 500, Add	<b>MOD: 0162</b>	Installation	140.00	\$1.82	SF	1.1579	\$295.03
Accepted		<i>History: 1.1 Added, 1.2 Modified, 1.3 Modified, 2.0 Accepted</i>							

Includes Labor Yes Includes Equipment Yes Includes Materials No

User Note: Area outside Warehouse in front of Staff Restroom

Item Note:

<b>Total:</b>	<b>\$295.03</b>
---------------	-----------------

14	033543000005	For >1,000 To 2,500, Add	<b>MOD: 0164</b>	Installation	1,645.00	\$1.11	SF	1.1579	\$2,114.27
Accepted		<i>History: 1.1 Added, 1.2 Modified, 1.3 Modified, 2.0 Accepted</i>							

Includes Labor Yes Includes Equipment Yes Includes Materials No

User Note: Warehouse less Sup Off

Item Note:

<b>Total:</b>	<b>\$2,114.27</b>
---------------	-------------------

<b>05 Metals</b>								<b>\$5,397.76</b>
------------------	--	--	--	--	--	--	--	-------------------

Record #	CSI Number	Description	Type	Quantity	Unit Price	UOM	Factor	Line Total
----------	------------	-------------	------	----------	------------	-----	--------	------------

\* Includes Price Changes due to Construction Task Catalog update



# Price Proposal Detail Report

## By Division

Version: 2.0

Approved

Proposal Value: \$220,792.67

Approved Date: March 12, 2024

Job Order: MTSJOC324-48

Job Order Name: Building B Offices Improvements

Location: Building B 1341 Commercial Street San Diego, CA 92101

Contractor: ABC General Inc.

Contract Number: PWG324.0-21

Contract Name: JOC Building and Facilities Construction Services. - Option 3

15	050519000047	3/8" Diameter x 5" Length, 304/18-8 Stainless Steel, Wedge Anchor Expansion Bolt	Installation	64.00	\$15.07	EA	1.1579	\$1,116.77
<b>Accepted</b>		<i>History: 1.1 Added, 1.2 Accepted, 1.3 Accepted, 2.0 Accepted</i>	<b>Demo:</b>	0.000000	\$0.00	EA	1.1579	\$0.00
<b>Includes Labor Yes Includes Equipment Yes Includes Materials Yes</b>								

**User Note:** Anchoring for new SS shelving - Wall

**Item Note:**

<b>Total:</b>	<b>\$1,116.77</b>
---------------	-------------------

16	050519000152	1/2" Bolt Diameter, 304/18-8 Stainless Steel, Multi-Set Drop- In Anchor	Installation	96.00	\$26.31	EA	1.1579	\$2,924.58
<b>Accepted</b>		<i>History: 1.1 Added, 1.2 Accepted, 1.3 Accepted, 2.0 Accepted</i>	<b>Demo:</b>	0.000000	\$0.00	EA	1.1579	\$0.00
<b>Includes Labor Yes Includes Equipment Yes Includes Materials Yes</b>								

**User Note:** Anchoring for new SS shelving - Floor

**Item Note:**

<b>Total:</b>	<b>\$2,924.58</b>
---------------	-------------------

17	055213000031	Stainless Steel, Wire Mesh Or Welded Wire Mesh, Railing Infill Panel	Installation	72.00	\$16.27	SF	1.1579	\$1,356.41
<b>Accepted</b>		<i>History: 1.1 Added, 1.2 Accepted, 1.3 Accepted, 2.0 Accepted</i>	<b>Demo:</b>	0.000000	\$0.00	SF	1.1579	\$0.00
<b>Includes Labor No Includes Equipment No Includes Materials Yes</b>								

<b>Total:</b>	<b>\$1,356.41</b>
---------------	-------------------

**09 Finishes** **\$93,282.40**

Record #	CSI Number	Description	Type	Quantity	Unit Price	UOM	Factor	Line Total
----------	------------	-------------	------	----------	------------	-----	--------	------------

\* Includes Price Changes due to Construction Task Catalog update

# Price Proposal Detail Report

## By Division

Version: 2.0

Approved

Proposal Value: \$220,792.67

Approved Date: March 12, 2024

Job Order: MTSJOC324-48

Job Order Name: Building B Offices Improvements

Location: Building B 1341 Commercial Street San Diego, CA 92101

Contractor: ABC General Inc.

Contract Number: PWG324.0-21

Contract Name: JOC Building and Facilities Construction Services. - Option 3

18	090120910002	Up To 2 SF, Cut And Patch Hole In Gypsum Board To Match Existing	Installation	188.00	\$16.95	SF	1.1579	\$3,689.76
Accepted		<i>History: 1.1 Added, 1.2 Accepted, 1.3 Accepted, 2.0 Accepted</i>	Demo:	0.000000	\$0.00	SF	1.1579	\$0.00
Includes Labor Yes Includes Equipment Yes Includes Materials Yes								

User Note: Wall prep/repair before painting

Item Note: Per location.

<b>Total:</b>	<b>\$3,689.76</b>
---------------	-------------------

19	090160910012	Grinding Of Existing Concrete Floor Prior To Installation Of Flooring	Installation	273.00	\$7.60	SY	1.1579	\$2,402.41
Accepted		<i>History: 1.1 Added, 1.2 Modified, 1.3 Modified, 2.0 Accepted</i>	Demo:	0.000000	\$0.00	SY	1.1579	\$0.00
Includes Labor Yes Includes Equipment Yes Includes Materials No								

**Owner Comments:** V:1.2-472sy = 4,248 sqft. Total qty of carpet is 1,800sqft. Revenue Area=610sqft and Staff Offices and Break Area = 1,200sqft. Kindly double check

User Note: Flooring prep  
Carpet Area 2,459SF

Item Note:

<b>Total:</b>	<b>\$2,402.41</b>
---------------	-------------------

20	090160910013	Chemical Prepare Existing Concrete Floor Prior To Installation Of Flooring	Installation	273.00	\$6.64	SY	1.1579	\$2,098.95
Accepted		<i>History: 1.1 Added, 1.2 Modified, 1.3 Modified, 2.0 Accepted</i>	Demo:	0.000000	\$0.00	SY	1.1579	\$0.00
Includes Labor Yes Includes Equipment Yes Includes Materials Yes								

**Owner Comments:** V:1.2-472sy = 4,248 sqft. Total qty of carpet is 1,800sqft. Revenue Area=610sqft and Staff Offices and Break Area = 1,200sqft. Kindly double check

User Note: Flooring prep  
Carpet Area 2,459SF

Item Note:

<b>Total:</b>	<b>\$2,098.95</b>
---------------	-------------------

\* Includes Price Changes due to Construction Task Catalog update

# Price Proposal Detail Report

## By Division

Version: 2.0

Approved

Proposal Value: \$220,792.67

Approved Date: March 12, 2024

Job Order: MTSJOC324-48

Job Order Name: Building B Offices Improvements

Location: Building B 1341 Commercial Street San Diego, CA 92101

Contractor: ABC General Inc.

Contract Number: PWG324.0-21

Contract Name: JOC Building and Facilities Construction Services. - Option 3

21	090190520014	Hand Wash, Minor Repair And Light Sanding Drywall Surfaces, Surface Preparation	Installation	9,340.00	\$0.47	SF	1.1579	\$5,082.95
<b>Accepted</b>		<i>History: 1.1 Added, 1.2 Modified, 1.3 Modified, 2.0 Accepted</i>	<b>Demo:</b>	0.000000	\$0.00	SF	1.1579	\$0.00

**Includes Labor Yes Includes Equipment Yes Includes Materials No**

**Owner Comments:** V:1.2-Total walls = 6886sqft

**User Note:** Wall prep/repair before painting  
Total painted Walls in 9,340SF  
(See matrix submitted)

**Item Note:**

<b>Total:</b>	<b>\$5,082.95</b>
---------------	-------------------

22	090190520014	For Up To 100, Add	<b>MOD: 0323</b>	Installation	9,340.00	\$0.94	SF	1.1579	\$10,165.90
<b>Accepted</b>		<i>History: 1.1 Added, 1.2 Modified, 1.3 Modified, 2.0 Accepted</i>							

**Includes Labor Yes Includes Equipment Yes Includes Materials No**

**User Note:** All small rooms phased out

**Item Note:**

<b>Total:</b>	<b>\$10,165.90</b>
---------------	--------------------

23	090190520015	Scrape, Repair And Sand Severely Damaged Drywall Surfaces, Surface Preparation	Installation	934.00	\$0.87	SF	1.1579	\$940.89
<b>Accepted</b>		<i>History: 1.1 Added, 1.2 Accepted, 1.3 Accepted, 2.0 Accepted</i>	<b>Demo:</b>	0.000000	\$0.00	SF	1.1579	\$0.00

**Includes Labor Yes Includes Equipment Yes Includes Materials Yes**

**User Note:** Wall prep/repair before painting

**Item Note:**

<b>Total:</b>	<b>\$940.89</b>
---------------	-----------------

24	090190520015	For Up To 100, Add	<b>MOD: 0323</b>	Installation	934.00	\$1.64	SF	1.1579	\$1,773.62
<b>Accepted</b>		<i>History: 1.1 Added, 1.2 Accepted, 1.3 Accepted, 2.0 Accepted</i>							

**Includes Labor Yes Includes Equipment Yes Includes Materials No**

**User Note:** All small rooms phased out

**Item Note:**

<b>Total:</b>	<b>\$1,773.62</b>
---------------	-------------------

\* Includes Price Changes due to Construction Task Catalog update

# Price Proposal Detail Report

## By Division

Version: 2.0

Approved

Proposal Value: \$220,792.67

Approved Date: March 12, 2024

Job Order: MTSJOC324-48

Job Order Name: Building B Offices Improvements

Location: Building B 1341 Commercial Street San Diego, CA 92101

Contractor: ABC General Inc.

Contract Number: PWG324.0-21

Contract Name: JOC Building and Facilities Construction Services. - Option 3

25	096513330005	Removal Of Glue From Concrete Floor	Installation	2,459.00	\$0.85	SF	1.1579	\$2,420.18
<b>Accepted</b>		<i>History: 1.1 Added, 1.2 Modified, 1.3 Modified, 2.0 Accepted</i>	<b>Demo:</b>	0.000000	\$0.00	SF	1.1579	\$0.00

**Includes Labor Yes Includes Equipment No Includes Materials No**

**Owner Comments:** V:1.2-Total qty of carpet is 1,800sqft. Revenue Area=610sqft and Staff Offices and Break Area = 1,200sqft

**User Note:** Flooring prep

**Item Note:** For removal of glue from VCT or carpet placement. Not to be used in conjunction with demolition tasks associated with floor tile installation.

<b>Total:</b>	<b>\$2,420.18</b>
---------------	-------------------

26	096816000031	38 Ounce, Heavy Traffic, Non Patterned, Nylon Broadloom Carpet	Installation	273.00	\$44.82	SY	1.1579	\$14,167.90
<b>Accepted</b>		<i>History: 1.1 Added, 1.2 Modified, 1.3 Modified, 2.0 Accepted</i>	<b>Demo:</b>	472.000000	\$19.77	SY	1.1579	\$10,804.87

**Includes Labor Yes Includes Equipment Yes Includes Materials Yes**

**Owner Comments:** V:1.2-472sy = 4,248 sqft. Total qty of carpet is 1,800sqft. Revenue Area=610sqft and Staff Offices and Break Area = 1,200sqft. Kindly double check

**User Note:** New 2,459SF = 273SY

**Item Note:**

<b>Total:</b>	<b>\$24,972.77</b>
---------------	--------------------

27	096816000031	For Up To 15, Add	<b>MOD: 0359</b>	Installation	472.00	\$2.64	SY	1.1579	\$1,442.84
<b>Accepted</b>		<i>History: 1.1 Added, 1.2 Modified, 1.3 Modified, 2.0 Accepted</i>							

**Includes Labor Yes Includes Equipment Yes Includes Materials No**

**User Note:** All small rooms phased out

**Item Note:**

<b>Total:</b>	<b>\$1,442.84</b>
---------------	-------------------

\* Includes Price Changes due to Construction Task Catalog update

# Price Proposal Detail Report

## By Division

Version: 2.0

Approved

Proposal Value: \$220,792.67

Approved Date: March 12, 2024

Job Order: MTSJOC324-48

Job Order Name: Building B Offices Improvements

Location: Building B 1341 Commercial Street San Diego, CA 92101

Contractor: ABC General Inc.

Contract Number: PWG324.0-21

Contract Name: JOC Building and Facilities Construction Services. - Option 3

28	099123000062	1 Coat Primer, Brush/Roller Work, Paint Interior Plaster/Drywall Walls	Installation	9,340.00	\$0.55	SF	1.1579	\$5,948.13
Accepted		<i>History: 1.1 Added, 1.2 Modified, 1.3 Modified, 2.0 Accepted</i>	Demo:	0.000000	\$0.00	SF	1.1579	\$0.00

**Includes Labor Yes Includes Equipment Yes Includes Materials Yes**

**Owner Comments:** V:1.2-Total walls = 6886sqft

**User Note:** 9,340SF Walls  
 Total painted Walls in 9,340SF  
 (See matrix submitted)

**Item Note:**

<b>Total:</b>	<b>\$5,948.13</b>
---------------	-------------------

29	099123000062	For Up To 100, Add	<b>MOD: 0278</b>	Installation	9.00	\$0.35	SF	1.1579	\$3.65
Accepted		<i>History: 1.1 Added, 1.2 Modified, 1.3 Modified, 2.0 Accepted</i>							

**Includes Labor Yes Includes Equipment Yes Includes Materials Yes**

**User Note:** All small rooms phased out

**Item Note:**

<b>Total:</b>	<b>\$3.65</b>
---------------	---------------

30	099123000064	2 Coats Paint, Brush/Roller Work, Paint Interior Plaster/Drywall Walls	Installation	9,340.00	\$1.09	SF	1.1579	\$11,788.12
Accepted		<i>History: 1.1 Added, 1.2 Modified, 1.3 Modified, 2.0 Accepted</i>	Demo:	0.000000	\$0.00	SF	1.1579	\$0.00

**Includes Labor Yes Includes Equipment Yes Includes Materials Yes**

**Owner Comments:** V:1.2-Total walls = 6886sqft

**User Note:** 9,340SF Walls  
 Total painted Walls in 9,340SF  
 (See matrix submitted)

**Item Note:**

<b>Total:</b>	<b>\$11,788.12</b>
---------------	--------------------

31	099123000064	For Up To 100, Add	<b>MOD: 0278</b>	Installation	9,340.00	\$0.71	SF	1.1579	\$7,678.50
Accepted		<i>History: 1.1 Added, 1.2 Modified, 1.3 Modified, 2.0 Accepted</i>							

**Includes Labor Yes Includes Equipment Yes Includes Materials Yes**

**User Note:** All small rooms phased out

**Item Note:**

<b>Total:</b>	<b>\$7,678.50</b>
---------------	-------------------

\* Includes Price Changes due to Construction Task Catalog update

# Price Proposal Detail Report

## By Division

Version: 2.0

Approved

Proposal Value: \$220,792.67

Approved Date: March 12, 2024

Job Order: MTSJOC324-48

Job Order Name: Building B Offices Improvements

Location: Building B 1341 Commercial Street San Diego, CA 92101

Contractor: ABC General Inc.

Contract Number: PWG324.0-21

Contract Name: JOC Building and Facilities Construction Services. - Option 3

32	099123000128	1 Coat Primer, Brush/Roller Work, Paint Interior Acoustical Ceiling	Installation	0.00	\$0.65	SF	1.1579	\$0.00
Accepted		<i>History: 1.1 Added, 1.2 Modified, 1.3 Accepted, 2.0 Accepted</i>	Demo:	0.000000	\$0.00	SF	1.1579	\$0.00

Includes Labor No Includes Equipment No Includes Materials No

Owner Comments: V:1.2-Removed.

User Note: 4,244SF Ceilings

Item Note:

Total:	\$0.00
--------	--------

33	099123000128	For Up To 100, Add	MOD: 0278	Installation	4,244.00	\$0.43	SF	1.1579	\$2,113.07
Accepted		<i>History: 1.1 Added, 1.2 Modified, 1.3 Accepted, 2.0 Accepted</i>							

Includes Labor Yes Includes Equipment Yes Includes Materials Yes

User Note: All small rooms phased out

Item Note:

Total:	\$2,113.07
--------	------------

34	099123000130	2 Coats Paint, Brush/Roller Work, Paint Interior Acoustical Ceiling	Installation	4,244.00	\$1.17	SF	1.1579	\$5,749.53
Accepted		<i>History: 1.1 Added, 1.2 Accepted, 1.3 Accepted, 2.0 Accepted</i>	Demo:	0.000000	\$0.00	SF	1.1579	\$0.00

Includes Labor Yes Includes Equipment Yes Includes Materials Yes

User Note: 4,244SF Ceilings

Item Note:

Total:	\$5,749.53
--------	------------

35	099123000130	For Up To 100, Add	MOD: 0278	Installation	4,244.00	\$0.78	SF	1.1579	\$3,833.02
Accepted		<i>History: 1.1 Added, 1.2 Accepted, 1.3 Accepted, 2.0 Accepted</i>							

Includes Labor Yes Includes Equipment Yes Includes Materials Yes

User Note: All small rooms phased out

Item Note:

Total:	\$3,833.02
--------	------------

\* Includes Price Changes due to Construction Task Catalog update

# Price Proposal Detail Report

## By Division

Version: 2.0

Approved

Proposal Value: \$220,792.67

Approved Date: March 12, 2024

Job Order: MTSJOC324-48

Job Order Name: Building B Offices Improvements

Location: Building B 1341 Commercial Street San Diego, CA 92101

Contractor: ABC General Inc.

Contract Number: PWG324.0-21

Contract Name: JOC Building and Facilities Construction Services. - Option 3

36	099313530003	Stain Sealer, Brush/Roller Work	Installation	1,785.00	\$0.57	SF	1.1579	\$1,178.11
<b>Accepted</b>		<i>History: 1.1 Added, 1.2 Accepted, 1.3 Accepted, 2.0 Accepted</i>	<b>Demo:</b>	0.000000	\$0.00	SF	1.1579	\$0.00
<b>Includes Labor Yes Includes Equipment Yes Includes Materials Yes</b>								

User Note: Warehouse

Item Note:

<b>Total:</b>	<b>\$1,178.11</b>
---------------	-------------------

<b>10 Specialties</b>	<b>\$21,760.25</b>
-----------------------	--------------------

Record #	CSI Number	Description	Type	Quantity	Unit Price	UOM	Factor	Line Total
37	102616130022	2" High, 1-3/4" Deep, D-Shaped, Rubber Wall Guard (Pawling D-2)	Installation	934.00	\$15.07	LF	1.1579	\$16,297.88
<b>Accepted</b>		<i>History: 1.1 Added, 1.2 Accepted, 1.3 Accepted, 2.0 Accepted</i>	<b>Demo:</b>	934.000000	\$3.10	LF	1.1579	\$3,352.58
<b>Includes Labor Yes Includes Equipment Yes Includes Materials Yes</b>								

User Note: New Wall base

Item Note:

<b>Total:</b>	<b>\$19,650.46</b>
---------------	--------------------

38	105616000005	Built-in Wood Storage Shelving Closet Shelf Of Pine With Rod	Installation	96.00	\$18.98	SF	1.1579	\$2,109.79
<b>Accepted</b>		<i>History:</i>	<b>Demo:</b>	0.000000	\$4.46	SF	1.1579	\$0.00
<b>Includes Labor Yes Includes Equipment Yes Includes Materials Yes</b>								

User Note: New custom wood shelving around printer in counting room Estimate 12x8

Item Note:

<b>Total:</b>	<b>\$2,109.79</b>
---------------	-------------------

<b>11 Equipment</b>	<b>\$34,902.63</b>
---------------------	--------------------

Record #	CSI Number	Description	Type	Quantity	Unit Price	UOM	Factor	Line Total
----------	------------	-------------	------	----------	------------	-----	--------	------------

\* Includes Price Changes due to Construction Task Catalog update

# Price Proposal Detail Report

## By Division

Version: 2.0

Approved

Proposal Value: \$220,792.67

Approved Date: March 12, 2024

Job Order: MTSJOC324-48

Job Order Name: Building B Offices Improvements

Location: Building B 1341 Commercial Street San Diego, CA 92101

Contractor: ABC General Inc.

Contract Number: PWG324.0-21

Contract Name: JOC Building and Facilities Construction Services. - Option 3

39	114123000486	21" x 60" Stainless Steel Modular Wire Shelving, 5 Tier, 74" Posts	Installation	8.00	\$3,767.88	EA	1.1579	\$34,902.63
Accepted		<i>History: 1.1 Added, 1.2 Accepted, 1.3 Accepted, 2.0 Accepted</i>	Demo:	8.000000	\$0.00	EA	1.1579	\$0.00
Includes Labor Yes Includes Equipment Yes Includes Materials Yes								

User Note: "Like" new custom stainless steel shelving. 5 for front room, 3 for safe room

Item Note:

Total: \$34,902.63

12 Furnishings \$16,821.77

Record #	CSI Number	Description	Type	Quantity	Unit Price	UOM	Factor	Line Total
40	123116000099	16 Gauge Stainless Steel Countertop Without Backsplash	Installation	65.00	\$73.42	SF	1.1579	\$5,525.85
Accepted		<i>History: 1.1 Added, 1.2 Accepted, 1.3 Accepted, 2.0 Accepted</i>	Demo:	0.000000	\$4.81	SF	1.1579	\$0.00
Includes Labor Yes Includes Equipment Yes Includes Materials Yes								

User Note: "Like" New custom Counting table top

Item Note:

Total: \$5,525.85

41	125523000025	6-MRN, Pedestal Table, 63-1/2" x 39-1/2" Stainless Steel Table Top, Up To 20	Installation	6.00	\$1,625.92	EA	1.1579	\$11,295.92
Accepted		<i>History: 1.1 Added, 1.2 Accepted, 1.3 Accepted, 2.0 Accepted</i>	Demo:	0.000000	\$122.49	EA	1.1579	\$0.00
Includes Labor Yes Includes Equipment Yes Includes Materials Yes								

User Note: "Like" new custom stainless steel counting table base

Item Note:

Total: \$11,295.92

26 Electrical \$21,850.50

Record #	CSI Number	Description	Type	Quantity	Unit Price	UOM	Factor	Line Total
----------	------------	-------------	------	----------	------------	-----	--------	------------

\* Includes Price Changes due to Construction Task Catalog update



# Price Proposal Detail Report

## By Division

Version: 2.0

Approved

Proposal Value: \$220,792.67

Approved Date: March 12, 2024

Job Order: MTSJOC324-48

Job Order Name: Building B Offices Improvements

Location: Building B 1341 Commercial Street San Diego, CA 92101

Contractor: ABC General Inc.

Contract Number: PWG324.0-21

Contract Name: JOC Building and Facilities Construction Services. - Option 3

42	260923000148	18 Zone, Surface Mount, 0 To 10 Volt Dimming, Wireless (ZigBee) LED Lighting Control Panel (PlanLED GigaTera IPC18Z)	Installation	2.00	\$1,139.06	EA	1.1579	\$2,637.84
Accepted		<i>History: 1.1 Added, 1.2 Accepted, 1.3 Accepted, 2.0 Accepted</i>	Demo:	0.000000	\$110.73	EA	1.1579	\$0.00
Includes Labor Yes Includes Equipment Yes Includes Materials Yes								

User Note: New dimmers for Rev. office and Warehouse

Item Note:

								<b>Total:</b>	<b>\$2,637.84</b>
--	--	--	--	--	--	--	--	---------------	-------------------

43	265119000094	2' x 4', 4,600 Lumens, Surface Mount, Shadow Box Style LED Fixture (Lithonia 2SBSLX4)	Installation	26.00	\$604.58	EA	1.1579	\$18,201.12
Accepted		<i>History: 1.1 Added, 1.2 Accepted, 1.3 Accepted, 2.0 Accepted</i>	Demo:	26.000000	\$33.60	EA	1.1579	\$1,011.54
Includes Labor Yes Includes Equipment Yes Includes Materials Yes								

<b>Total:</b>	<b>\$19,212.66</b>
---------------	--------------------

<b>Proposal Total:</b>								<b>\$220,792.67</b>
------------------------	--	--	--	--	--	--	--	---------------------

Div	<b>The Percentage of Non Pre-Priced on this Proposal:</b>							<b>0.0%</b>
-----	---	--	--	--	--	--	--	-------------

\* Includes Price Changes due to Construction Task Catalog update

EXHIBIT C  
(Subcontractor Listing)

# San Diego Metropolitan Transit System

1255 Imperial Ave  
San Diego, CA 92101

## Subcontractor Report

Date: 3/12/2024  
Job Order Contracting

**Contract #:** PWG324.0-21  
**Job Order #:** MTSJOC324-48  
**Job Order Title:** Building B Offices Improvements  
**Job Order Value:** \$220,792.67  
**Location:** Building B  
**Contractor:** ABC General Inc.  
**Subcontractors:** A&S Flooring Inc.  
 Harborside Construction Inc  
 Swift Electric

Subcontractor Name	License Number	Describe Nature of Work (Trade)	Certifications	Subcontractor Total	%
A&S Flooring Inc. 2461 Fenton St, Chula Vista, CA 91914	801134	Carpet layer		\$35,745.00	16.19%
Harborside Construction Inc 2010 Garrison Way, El Cajon, CA 92019	730817	Painting		\$60,000.00	27.17%
Swift Electric 12515 Woodside Ave #906, Lakeside, CA 92040	915171	Electrician		\$28,700.00	13.00%

### Summary

Certification Name	Value	%
	\$124,445.00	27.17%
<b>Total</b>	<b>\$124,445.00</b>	<b>56.36%</b>



**Metropolitan  
Transit  
System**

**DRAFT FOR EXECUTIVE COMMITTEE REVIEW DATE: 4/11/2024**

## **Agenda Item No. 17**

MEETING OF THE SAN DIEGO METROPOLITAN TRANSIT SYSTEM  
BOARD OF DIRECTORS

April 25, 2024

**SUBJECT:**

El Cajon Third Track Construction Management (CM) Services – Work Order Amendment

**RECOMMENDATION:**

That the San Diego Metropolitan Transit System (MTS) Board of Directors authorize the Chief Executive Officer (CEO) to execute Work Order Amendment No. WOA2498-CM02.02 under MTS Doc. No. G2498.0-21 (in substantially the same format as Attachment A), with Kleinfelder Construction Services, Inc. (KCS), for the El Cajon Third Track and El Cajon Third Track – Interlocking E26 CM services in the amount of \$411,792.40.

**Budget Impact**

The total cost of this amendment is estimated to be \$411,792.40, and the total cost for this contract is estimated to be \$1,910,165.46. This project is funded by the Capital Improvement Program (CIP) account 2005113501 – El Cajon Third Track and CIP account 2005104101 – Signal Upgrade for El Cajon Third Track – INT E26.

**DISCUSSION:**

The El Cajon Third Track Project adds a new siding track and a 23-foot platform extension at the El Cajon Transit Center (ECTC). This will bring the total tracks at the ECTC to three: the first for westbound Orange Line and Green Line service, the second for eastbound Orange Line and Green Line service, and the third, a new track, to accommodate a two-car train that can be operated between the ECTC and the Green Line terminal station in Santee.

As part of the project, a new turnout is being installed on the mainline, and approximately 480 feet of new track is being constructed to connect the new siding track to the mainline. An additional crossover will be constructed for operational flexibility north of the station on the current MTS mainline, south of Wagner Drive. This project will improve operational efficiencies between ECTC and Santee Town Center Station.

The construction contract for this project was approved by the MTS Board of Directors on May 12, 2022 (Agenda Item (AI) 11) and construction began on July 5, 2022.



MTS requires CM services to assist staff with the coordination, control, and oversight of the construction contractor from the beginning of work through completion (collectively “CM Services”). The Work Order for CM Services includes civil, track, signaling, and catenary power inspections, and the assistance of a resident engineer and field inspector at various times throughout construction.

On May 12, 2022 (AI 12), the Board approved the original Work Order for this project. Kleinfelder Construction Services, Inc. (KCS) was chosen as the most qualified firm after a request for proposal process with MTS’s On-Call CM Services Panel. The CM Work Order value and period of performance was based on the expectation of a one-year construction period. Due to additional extended lead times for materials and the intricate nature of the project, on October 19, 2023 (AI 9), the Board approved Amendment No. 1 extending the work order and adding additional funds through February 2024.

Staff now anticipates that the project will require extra time for completion and closeout. Construction is currently estimated to be complete in June 2024. The remaining work requires four weekend shutdowns of trolley services to complete the track, signaling, and OCS work. The Capital Projects and Procurement teams are separately working with the construction contractor to review and evaluate the basis for the schedule delays and any remedies available to MTS.

The KCS Work Order and amendments are summarized below:

Work Order No.	Purpose	Amount	Board Approval Date
WOA2498-CM02	Original Work Order - CM	\$999,582.29	05/12/22, AI 12
WOA2498-CM02.01	Add funds and time to Work Order	\$498,790.77	10/19/23, AI 9
WOA2498-CM02.02	Add additional funds and time to Work Order	\$411,792.40	Today’s Proposed Action
	<b>Total</b>	<b>\$1,910,165.46</b>	

KCS’s proposed fee amount of \$411,792.40 is less than MTS’s Independent Cost Estimate (ICE) of \$434,280.00 and was determined to be fair and reasonable. For this project, KCS will utilize the following subcontractors:

Subcontractor Name	Subcontractor Certification	Subcontract Amount
CA Wehsener Engineering	N/A	\$77,351.92
Destination Enterprises	SB, LGBTBE, WBE	\$41,665.37

Therefore, staff recommends that the MTS Board of Directors authorize the CEO to execute Work Order Amendment No. WOA2498-CM02.02 under MTS Doc. No. G2498.0-21 (in substantially the same format as Attachment A), with KCS, for the El Cajon Third Track and El Cajon Third Track – Interlocking E26 CM services in the amount of \$411,792.40.

/s/ Sharon Cooney  
 Sharon Cooney  
 Chief Executive Officer

Key Staff Contact: Julia Tuer, 619.557.4515, [Julia.Tuer@sdmts.com](mailto:Julia.Tuer@sdmts.com)

Attachment: A. Draft Work Order Amendment No. WOA2498-CM02.02



# Metropolitan Transit System

April 25, 2024

MTS Doc. No. G2498.0-21  
Work Order No. WOA2498-CM02.02

Marc McIntyre  
Project/Task Order Manager Kleinfelder Construction Services, Inc.  
5761 Copley Dr. Ste. 100 San Diego, CA 92101  
Dear Marc McIntyre:

Subject: AMENDMENT NO. 2 TO WOA2498-CM02, TO MTS DOC. NO. G2498.0-21, EL CAJON THIRD TRACK, CONSTRUCTION MANAGEMENT (CM) SERVICES WORK ORDER AGREEMENT

This letter shall serve as Amendment No. 2 to our agreement WOA2498-CM02, to MTS Doc. No. G2498.0-21 for Construction Management services under the Construction Management Consultant Agreement, as further described below.

## SCOPE OF SERVICES

There shall be no change to the Scope of Services as a result of this Amendment. This Amendment shall provide additional funds and time to the agreement for CM services for the El Cajon Third Track Construction.

## SCHEDULE

As a result of this Amendment, the Schedule shall be extended by four (4) months. The Schedule shall follow contract PWL341.0-22 El Cajon Third Track Construction with Shimmick Construction Company, Inc. which was for a period of three hundred sixty (360) calendar days from the issuance of the Notice to Proceed to the construction contractor. The NTP was issued on September 26, 2022. Inclusive of this schedule, acknowledging the construction project may experience delays/extensions, the period of performance of this work order shall be for two hundred seventy (300) days.

## PAYMENT

As a result of this Amendment, the Payment shall be increased by \$411,792.40. The Payment based on actual costs in the revised not-to-exceed amount of \$1,910,165.46. Payment shall not be increased without prior written authorization of MTS (Attachment A).



Please sign below, and return the document to the Contracts Specialist at MTS. All other terms and conditions shall remain the same and in effect.

Sincerely,

Accepted:

Sharon Cooney  
Chief Executive Officer

\_\_\_\_\_  
Marc McIntyre  
Kleinfelder Construction Svcs. Inc.

Date:

Attachments: A - Negotiated Fee Proposal

DRAFT

ATTACHMENT A  
NEGOTIATED FEE PROPOSAL

DRAFT



## Work Order Estimate Summary

**MTS Doc. No.** G2498.0-21  
**Work Order No.** WOA2498-CMO2 Amendment 02  
**Attachment:** B

**Work Order Title:** El Cajon Third Track CM

**Project No:** WOA2498-CMO2

**Table 1 - Cost Codes Summary (Costs & Hours)**

Item	Cost Codes	Cost Codes Description	Total Costs
1	0270	Construction Management and Inspection Services	\$411,792.40
Totals =			<b>\$411,792.40</b>

**Table 2 - TASKS/WBS Summary (Costs & Hours)**

Item	TASKS/WBS	TASKS/WBS Description	Labor Hrs	Total Costs
1	1	Project / Task Order Management	36.0	\$5,740.81
2	2	Engineering / Inspection	1,856.0	\$392,334.56
3	3	Materials Sampling and Testing	50.0	\$13,717.04
Totals =			<b>1,942.0</b>	<b>\$411,792.40</b>

**Table 3 - Consultant/Subconsultant Summary (Costs & Hours)**

(If Applicable, Select One)				Consultant	Labor Hrs	Total Costs
DBE	DVBE	SBE	Other			
			X	Kleinfelder Construction Services *	1,312.0	\$279,058.08
		X		CA Wehsener Engineering	384.0	\$77,351.92
			X	Kleinfelder	50.0	\$13,717.04
X		X		Destination Enterprises	196.0	\$41,665.37
Totals =					<b>1,942.0</b>	<b>\$411,792.40</b>

**NOTES**

1. Field inspection and materials testing rates have been adjusted as necessary to comply with prevailing wage DIR Determination SD-23-63-3-2021-1D. Rates are calculated using assumed fringe value of \$12/hr. Actual rates are calculated monthly per SANDAG direction.
2. Billing rates included in this cost proposal are based upon the published rate table incorporated into Contract G2498.0-21 and as finalized by SANDAG under Contract 550870

Total Hours = **1,312**  
 Total Costs = **\$279,058.08**

Consultant/Subconsultant: **Kleinfelder Construction Services, Inc**

MTS Doc. No.: **G2498.0-21**

Work Order No.: **WOA2498-CMO2** Amendment 02

Work Order Title: **El Cajon Third Track CM**

Attachment: **B**

Item	TASKS/WBS	TASKS/WBS Description	ODCs (See Attachment)	Michalle Beringhaus - Task Order Manager - July 2023 - June 2024 Rate	Michalle Beringhaus - Task Order Manager - July 2024 - June 2025 Rate	Jesus Berrios - Project Controls II - July 2023 - June 2024 Rate	Jesus Berrios - Project Controls II - July 2024 - June 2025 Rate	Rex Crabtree - Building Inspector Group 2 PW - July 2023 - June 2024 Rate	Rex Crabtree - Building Inspector Group 2 PW - July 2024 - June 2025 Rate	Hank Gentile - Contract Manager Group 2 PW - July 2023 - June 2024 Rate	Keith Kranda - Senior Field Inspector Group 2 PW - July 2023 - June 2024 Rate	Keith Kranda - Senior Field Inspector Group 2 PW - July 2024 - June 2025 Rate	Hassan Mustafa - Engineer Supervising - July 2023 - June 2024 Rate	Hassan Mustafa - Engineer Supervising - July 2024 - June 2025 Rate	Total Hours	Totals	
				\$ 214.15	\$ 219.93	\$103.83	\$ 106.63	\$ 173.67	\$ 178.36	\$249.83	\$190.83	\$ 195.98	\$237.94	\$ 244.36			
1	<b>Task 1</b>	<b>Project / Task Order Management</b>															
		Project / Task Order Management		16	2	16	2								36	\$5,740.81	
															0	\$0.00	
		Subtotals (Hours) =	N/A	16	2	16	2	0	0	0	0	0	0	0	36	\$5,740.81	
		Subtotals (Costs) =	\$0.00	\$3,426.40	\$439.86	\$1,661.28	\$213.27	\$0.00	\$0.00	\$0.00	\$0.00	\$0.00	\$0.00	\$0.00	36	\$5,740.81	
2	<b>Task 2</b>	<b>Engineering / Inspection</b>															
		Engineering / Inspection	\$10,981.58					444	40		220	12	480	80	1,276	\$273,317.27	
															0	\$0.00	
		Subtotals (Hours) =	N/A	0	0	0	0	444	40	0	220	12	480	80	1,276	\$273,317.27	
		Subtotals (Costs) =	\$10,981.58	\$0.00	\$0.00	\$0.00	\$0.00	\$77,108.73	\$7,134.29	\$0.00	\$41,982.60	\$2,351.79	\$114,209.43	\$19,548.85	1,276	\$273,317.27	
3	<b>Task 3</b>	<b>Materials Sampling and Testing</b>															
		Materials Sampling and Testing	\$0.00					0							0	\$0.00	
															0	\$0.00	
		Subtotals (Hours) =	N/A	0	0	0	0	0	0	0	0	0	0	0	0	\$0.00	
		Subtotals (Costs) =	\$0.00	\$0.00	\$0.00	\$0.00	\$0.00	\$0.00	\$0.00	\$0.00	\$0.00	\$0.00	\$0.00	\$0.00	0	\$0.00	
		<b>Totals (Summary) =</b>															
		Total (Hours) =	N/A	16	2	16	2	444	40	0	220	12	480	80	1,312	\$279,058.08	
		Total (Costs) =	\$0.00	\$3,426.40	\$439.86	\$1,661.28	\$213.27	\$77,108.73	\$7,134.29	\$0.00	\$41,982.60	\$2,351.79	\$114,209.43	\$19,548.85	1312	\$279,058.08	
		Percentage of Total (Hours) =	0%	1%	0%	1%	0%	34%	3%	0%	17%	1%	37%	6%	100%		
		Percentage of Total (Costs) =	4%	1%	0%	1%	0%	28%	3%	0%	15%	1%	41%	7%		100%	

DRAFT

### Work Order Estimate Summary

Consultant/ Subconsultant: **Kleinfelder Construction Services, Inc**

Contract No: **G2498.0-21**

Task Order No. **WOA2498-CMO2** Amendment 02

Work Order Title: **El Cajon Third Track CM**

Attachment: **B**

#### TASKS/WBS (1-5)

ODC Item	Description	Unit	Unit Cost	Task 1		Task 2		Task 3		Task 4		Task 5	
				Quantity	Total	Quantity	Total	Quantity	Total	Quantity	Total	Quantity	Total
1	Field Vehicle	Month	\$1,377.00			7.98	\$10,981.58						
2													
3													
4													
5													
6													
				Subtotal =		Subtotal =	<b>\$10,981.58</b>	Subtotal =		Subtotal =		Subtotal =	

#### TASKS/WBS (6-10)

ODC Item	Description									Totals	
		Quantity	Total	Quantity	Total	Quantity	Total	Quantity	Total	Quantity	Total
1	Field Vehicle									7.98	\$10,981.58
2											
3											
4											
5											
6											
		Subtotal =		Subtotal =		Subtotal =		Subtotal =		Totals =	<b>\$10,981.58</b>



## Work Order Estimate Summary

Consultant/Subconsultant: **CA Wehsener Engineering**

MTS Doc. No.: **G2498.0-21**

Total Hours =	384
Total Costs =	\$77,351.92

Work Order No.: **WOA2498-CMO2** Amendment 02

Work Order Title: **El Cajon Third Track CM**

Attachment: **B**

Item	TASKS/WBS	TASKS/WBS Description	ODCs (See Attachment)	Chuck Wehsener - Engineer, Supervising 21/22	Chuck Wehsener - Engineer, Supervising 22/23	Chuck Wehsener - Engineer, Supervising 23/24	Thomas Wehsener - Building Inspection Group 2 PW 21/22	Javier Rangel - Building Inspection Group 2 PW 23/24	Total Hours	Totals
				\$ 217.86	\$ 223.74	\$ 229.78	\$154.07	\$190.91		
1	<b>Task 1</b>	<b>Project / Task Order Management</b>								
		Project / Task Order Management								
		Subtotals (Hours) =	N/A							
		Subtotals (Costs) =								
2	<b>Task 2</b>	<b>Engineering / Inspection</b>				104		280	384	\$77,351.92
		Engineering / Inspection				104		280	384	\$77,351.92
		Subtotals (Hours) =	N/A			104		280	384	\$77,351.92
		Subtotals (Costs) =			\$23,897.12			\$53,454.80	384	\$77,351.92
3	<b>Task 3</b>	<b>Materials Sampling and Testing</b>								
		Materials Sampling and Testing								
		Subtotals (Hours) =	N/A							
		Subtotals (Costs) =								
		Subtotals (Hours) =	N/A							
		Subtotals (Costs) =								
		<b>Totals (Summary) =</b>							<b>384</b>	<b>\$77,351.92</b>
		Total (Hours) =	N/A			104		280	384	
		Total (Costs) =			\$23,897.12			\$53,454.80		\$77,351.92
		Percentage of Total (Hours) =	N/A			27%		0.729166667	100%	
		Percentage of Total (Costs) =				31%		0.691059769		100%



## Work Order Estimate Summary

Total Hours = <span style="border: 1px solid black; padding: 2px 10px;"><b>50</b></span> Total Costs = <span style="border: 1px solid black; padding: 2px 10px;"><b>\$13,717.04</b></span>	Consultant/Subconsultant: <span style="border: 1px solid black; padding: 2px 10px;"><b>Kleinfelder, Inc.</b></span> Work Order Title: <span style="border: 1px solid black; padding: 2px 10px;"><b>EI Cajon Third Track CM</b></span>	MTS Doc. No.: <span style="border: 1px solid black; padding: 2px 10px;"><b>G2498.0-21</b></span> Work Order No.: <span style="border: 1px solid black; padding: 2px 10px;"><b>WOA2498-CMO2</b></span> Amendment 02 Attachment: <span style="border: 1px solid black; padding: 2px 10px;"><b>B</b></span>
---	--	--

Item	TASKS/WBS	TASKS/WBS Description	ODCs (See Attachment)	Chad Davis - Engineer, Supervising 21/22	Chad Davis - Engineer, Supervising 22/23	Chad Davis - Engineer, Supervising 23/24	Carl De La Torre - Building Inspection Grp 1 PW 21/22	Carl De La Torre - Building Inspection Grp 1 PW 22/23	Carl De La Torre - Building Inspection Grp 1 PW 23/24	Total Hours	Totals
1	<b>Task 1</b>	<b>Project / Task Order Management</b>		\$ 249.02	\$255.74	\$262.65	\$188.96	\$ 194.06	\$ 199.30		
		Project / Task Order Management									
		Subtotals (Hours) =	N/A								
		Subtotals (Costs) =									
2	<b>Task 2</b>	<b>Engineering / Inspection</b>									
		Engineering / Inspection									
		Subtotals (Hours) =	N/A								
		Subtotals (Costs) =									
3	<b>Task 3</b>	<b>Materials Sampling and Testing</b>		\$3,371.94		6			44	50	\$13,717.04
		Materials Sampling and Testing		\$3,371.94		6			44	50	\$13,717.04
		Subtotals (Hours) =	N/A			6			44	50	\$13,717.04
		Subtotals (Costs) =	\$3,371.94			\$1,575.90			\$8,769.20	<b>50</b>	<b>\$13,717.04</b>
		Subtotals (Hours) =	N/A								
		Subtotals (Costs) =									
		<b>Totals (Summary) =</b>								<b>50</b>	<b>\$13,717.04</b>
		Total (Hours) =	N/A			6			44	50	
		Total (Costs) =	\$3,371.94			\$1,575.90			\$8,769.20		\$13,717.04
		Percentage of Total (Hours) =	N/A			12%			88%	100%	
		Percentage of Total (Costs) =	25%			11%			64%		100%

### Work Order Estimate Summary

Consultant/ Subconsultant: **Kleinfelder**

Contract No: **G2498.0-21**  
 Task Order No. **WOA2498-CMO2** **Amendment 02**  
 Attachment: **B**

Work Order Title: **El Cajon Third Track CM**

#### TASKS/WBS (1-5)

ODC Item	Description	Unit	Unit Cost	Task 1		Task 2		Task 3		Task 4		Task 5	
				Quantity	Total	Quantity	Total	Quantity	Total	Quantity	Total	Quantity	Total
1	Lab Fees (various testing)	Estimate	\$3,056.00					1.0	\$3,056.00				
2	Field Vehicle	Month	\$1,011.00					0.3	\$315.94				
3													
4													
5													
6													
7													
8													
				Subtotal =		Subtotal =		Subtotal =	<b>\$3,371.94</b>	Subtotal =		Subtotal =	

#### TASKS/WBS (6-10)

ODC Item	Description									Totals	
		Quantity	Total	Quantity	Total	Quantity	Total	Quantity	Total	Quantity	Total
1										<b>1</b>	<b>\$3,056.00</b>
2										<b>0</b>	<b>\$315.94</b>
3											
4											
5											
6											
7											
8											
		Subtotal =		Subtotal =		Subtotal =		Subtotal =		Totals =	<b>\$3,371.94</b>



STATE OF CALIFORNIA - DEPARTMENT OF TRANSPORTATION

COST PROPOSAL  
 ON-CALL CONTRACT- OH & FEE ON DELTAS, WITH PREDETERMINED INCREASE, DIRECT LABOR METHOD OF ACCOUNTING  
 ADM 2033 (Rev. 10/23/18)

Determination Number: SD-23-63-3-2021-1D  
 - Issue Date: August 22, 2021  
 - Effective Date: September 1, 2021  
 - Expiration Date: \*June 30, 2022

Consultant/Subconsultant Name: Kleinfelder  
 Agreement Number: G2498.0-21  
 Attachment 2  
 Date Prepared: 5/19/2022  
 Page No.: 1 of 1

**Loaded Billing Rate Calculations:**

**Non-Exempt Employee Loaded Billing Rates:**  
 A) Straight Time (ST) Loaded Billing Rate = [Actual Hourly Rate + ST Delta Base + ST Delta Fringe] \* [(1 + Field OH) \* (1 + Fee)]  
 B) ST Loaded Billing Rate + (1.5 Base PW Rate - ST Base PW Rate) \* [(1+Field OH) \* (1+Fee)] or ST Loaded Billing Rate + (2.0 Base PW Rate - 1.5 Base PW Rate) \* [(1+Field OH) \* (1+Fee)]

**Exempt Employee Loaded Billing Rates- Compensated for PW OT:**  
 C) Straight Time (ST) Loaded Billing Rate = [Actual Hourly Rate + ST Delta Base + ST Delta Fringe] \* [(1 + Field OH) \* (1 + Fee)]  
 D) ST Loaded Billing Rate + (1.5 Base PW Rate - ST Base PW Rate) \* [(1+Field OH) \* (1+Fee)] or ST Loaded Billing Rate + (2.0 Base PW Rate - 1.5 Base PW Rate) \* [(1+Field OH) \* (1+Fee)]

**The PW Deltas (Base & Fringe) above for Loaded Billing Rates, are applicable for services covered under DIR determinations. Includes Exempt employees who are normally not paid for OT worked, per company policy.**

**Exempt Employee Loaded Billing Rates- Not Compensated for OT (Uncompensated OT):**  
 E) ST Loaded Billing Rate = Actual Hourly Rate \* [(1 + Home OH) \* (1 + Fee)]  
 F) No Overtime. Columns are shaded out - See Stevie Ray Vaughn Non-Prevailing Wage example, line 59.

**Exempt Employee Loaded Billing Rates- Compensated for OT @ ST Rate:**  
 G) ST Loaded Billing Rate = Actual Hourly Rate \* [(1 + Home OH) \* (1 + Fee)]  
 H) ST Loaded Billing Rate + (1.5 x 0) or ST Loaded Billing Rate + (2.0 x 0) See example for Bob Marley, line 47 and Alecia Moore, line 65, both Non-Prevailing Wage Work.

Home Office:	Fringe Benefit %	Overhead %	General Administration %	Combined %
NORMAL				= 158.02%
OVERTIME				= 158.02%
Field Office:	Fringe Benefit %	Overhead %	General Administration %	Combined %
NORMAL				= 158.02%
OVERTIME				= 158.02%
Project Specific:	Fringe Benefit %	Overhead %	General Administration %	Combined %
NORMAL				= 158.02%
OVERTIME				= 158.02%

FEE	=	8.50%
FCCM	=	0.00%

Applicable Delta Base Multiplier (Field/Home)	=	2.79952
Applicable Delta Fringe Multiplier Fringe (Field)	=	2.79952

Name & Work Information	Home / Field / Project Specific Personnel	Prevailing Wage Rate established by State DIR (only applicable for prevailing wage work)						Employee Actual Rate (fringe benefits vary year over year)						DELTA (TOTAL) = Employee Total Rate - DIR Rate			Applicable DELTA (TOTAL) = Employee Total - DIR Total			Applicable DELTA Base = DIR Rate - Employee Base Rate			Applicable DELTA FRINGE = DELTA TOTAL - DELTA BASE (Employee - DIR)			Loaded Hourly Billing Rates			Effective Date of Hourly Rate (Add RFQ/RFP Advertisement Date)		% Escalation Increase	Actual Hourly Rate	Hourly Range for Class		
		Base Salary			Fringe Benefits	Total Base Salary + Fringe Benefit			Base Salary			Actual Fringe	Total = Base + Fringe			Straight			1.5 OT			2.0 OT			Straight	1.5 OT	2.0 OT	From	To						
		Straight	1.5 OT	2.0 OT		Straight	1.5 OT	2.0 OT	Straight	1.5 OT	2.0 OT		Straight	1.5 OT	2.0 OT	Straight	1.5 OT	2.0 OT	Straight	1.5 OT	2.0 OT	Straight	1.5 OT	2.0 OT											
Carl De La Torre - Building Inspection Grp 1 4. Non-Exempt 5. Full Time	FIELD Prevailing Wage Work REG SHIFT	\$50.43	\$75.65	\$100.86	\$30.04	\$80.47	\$105.69	\$130.90	\$35.33	\$53.00	\$70.67	\$9.28	\$44.61	\$62.28	\$79.95	(\$35.86)	(\$43.40)	(\$50.95)	(\$35.86)	(\$43.40)	(\$50.95)	(\$15.10)	(\$22.64)	(\$30.19)	(\$20.76)	(\$20.76)	(\$20.76)	\$199.30	\$269.89	\$340.48	7/1/2023	6/30/2024	2.70%	\$ 35.33	N/A
		\$50.43	\$75.65	\$100.86	\$30.04	\$80.47	\$105.69	\$130.90	\$36.29	\$54.43	\$72.57	\$9.28	\$45.57	\$63.71	\$81.85	(\$34.90)	(\$41.97)	(\$49.05)	(\$34.90)	(\$41.97)	(\$49.05)	(\$14.14)	(\$21.21)	(\$28.29)	(\$20.76)	(\$20.76)	(\$20.76)	\$199.30	\$269.89	\$340.48	7/1/2024	6/30/2025	2.70%	\$ 36.29	N/A
Carl De La Torre - Building Inspection Grp 1 4. Non-Exempt 5. Full Time	FIELD Prevailing Wage Work SPECIAL SHIFT	\$50.43	\$75.65	\$100.86	\$30.04	\$80.47	\$105.69	\$130.90	\$35.02	\$52.53	\$70.05	\$9.28	\$44.30	\$61.81	\$79.33	(\$36.17)	(\$43.87)	(\$51.57)	(\$36.17)	(\$43.87)	(\$51.57)	(\$15.41)	(\$23.11)	(\$30.81)	(\$20.76)	(\$20.76)	(\$20.76)	\$199.30	\$269.89	\$340.48	1/1/2024	12/31/2024	3.00%	\$ 35.02	N/A
		\$50.43	\$75.65	\$100.86	\$30.04	\$80.47	\$105.69	\$130.90	\$36.07	\$54.11	\$72.15	\$9.28	\$45.35	\$63.39	\$81.43	(\$35.12)	(\$42.30)	(\$49.47)	(\$35.12)	(\$42.30)	(\$49.47)	(\$14.36)	(\$21.54)	(\$28.71)	(\$20.76)	(\$20.76)	(\$20.76)	\$199.30	\$269.89	\$340.48	1/1/2025	6/30/2025	3.00%	\$ 36.07	N/A



## Work Order Estimate Summary

Total Hours = 196  
 Total Costs = \$41,665.37

Consultant/Subconsultant: Destination Enterprises

MTS Doc. No.: G2498.0-21  
 Work Order No.: WOA2498-CMO2 Amendment 02

Work Order Title: El Cajon Third Track CM

Attachment: B

Item	TASKS/WBS	TASKS/WBS Description	ODCs (See Attachment)	Marcy Szarama Task Manager 23/24	Mark Crowley- Building Inspection Group 2 - PW 21/22	Mark Crowley- Building Inspection Group 2 - PW 22/23	Mark Crowley- Building Inspection Group 2 - PW 23/24					Total Hours	Totals
				\$ 205.41	\$201.55	\$206.99	\$212.58						
1	<b>Task 1</b>	<b>Project / Task Order Management</b>											
		Project / Task Order Management											
		Subtotals (Hours) =	N/A										
		Subtotals (Costs) =											
2	<b>Task 2</b>	<b>Engineering / Inspection</b>					196					196	\$ 41,665.37
		Engineering / Inspection					196					196	\$ 41,665.37
		Subtotals (Hours) =	N/A				196					196	\$41,665.37
		Subtotals (Costs) =					\$41,665.37					196	\$41,665.37
3	<b>Task 3</b>	<b>Materials Sampling and Testing</b>											
		Materials Sampling and Testing											
		Subtotals (Hours) =	N/A										
		Subtotals (Costs) =											
		Subtotals (Hours) =	N/A										
		Subtotals (Costs) =											
		<b>Totals (Summary) =</b>											
		Total (Hours) =	N/A				196					196	\$41,665.37
		Total (Costs) =					\$41,665.37					196	\$41,665.37
		Percentage of Total (Hours) =	N/A				100%					100%	
		Percentage of Total (Costs) =					100%					100%	100%

DRAFT





**Metropolitan  
Transit  
System**

**DRAFT FOR EXECUTIVE COMMITTEE REVIEW DATE: 4/11/2024**

## **Agenda Item No. 18**

MEETING OF THE SAN DIEGO METROPOLITAN TRANSIT SYSTEM  
BOARD OF DIRECTORS

April 25, 2024

**SUBJECT:**

Commercial Tenant Relocation and Property Management Services - Clean Transit  
Advancement Campus (CTAC) – Work Order Agreement

**RECOMMENDATION:**

That the San Diego Metropolitan Transit System (MTS) Board of Directors authorize the Chief Executive Officer (CEO) to execute Work Order WOA357-AE-39 under MTS Doc. No. PWL357.0-22 (in substantially the same format as Attachment A), with Chen Ryan Associates, Inc. (CRA), a Disadvantaged Business Enterprise (DBE), in the amount of \$533,448.30 to provide tenant relocation and property management services for the CTAC project.

**Budget Impact**

The total contract cost of this Work Order is estimated to be \$533,448.30. The project will be funded by the Capital Improvement Program (CIP) account 3004100801 – Clean Transit Advancement Campus.

**DISCUSSION:**

MTS is developing its sixth bus division, the CTAC, to support the electrification of the bus fleet and allow future service expansion. On October 20, 2022 (Agenda Item (AI) 30), the MTS Board selected “Site 7” on Federal Boulevard near 47th Street as the preferred site for the CTAC Project and adopted a Mitigated Negative Declaration, Mitigation Monitoring and Reporting Program.

MTS is in the process of acquiring, or seeking to acquire, the Site 7 properties. On March 5, 2024, MTS closed escrow and acquired three of the five parcels that make up Site 7: 4506-4520 Federal Boulevard (also known as the Nob Hill Industrial Park) and 4576-4588 Federal Boulevard.

MTS has identified approximately seventeen (17) commercial tenants in the various buildings on Site 7. Before MTS can begin demolition of the existing buildings and construction of the CTAC project, all tenants must be relocated in accordance with the Relocation Assistance and Real Property Acquisition Policies Act of 1970 (Uniform Act) and California Code of Regulations Title 25, § 6038. To comply with these regulations, a tenant relocation consultant is needed. The



tenant relocation consultant will interview and provide legally required notices to the tenants, negotiate tenant fixture and equipment reimbursements, provide relocation assistance to the tenants, and provide various documents and reports to MTS as required by law. The estimated tenant relocation timeline is twelve (12) to eighteen (18) months.

Property management services are also needed during this time. The Site 7 tenants will be MTS tenants and will require property management services to handle various property management issues. Once the tenants are relocated, the property will be vacant until the time MTS receives funding for design, demolition, and construction of the new CTAC project. During the vacant time frame, a property management consultant will continue to secure, maintain, and perform general as-needed services related to the property.

Today's proposed action would issue a work order to CRA to provide tenant relocation and property management services for the CTAC project.

#### Architectural and Engineering (A&E) Consultant Selection Process

On September 15, 2021, MTS issued a solicitation for On-Call A&E Design Services by Request for Statements of Qualifications (RFSQ) from firms with expertise in a variety of A&E design and related consulting services separated into the following three (3) categories:

- Category A: Comprehensive/Full Service - Five (5) prime contracts
- Category B: Small Business Set Aside- Three (3) prime contracts awarded to a certified Small Business (SB) or a DBE certified firm, (which is also considered to be a Small Business)
- Category C: Specialty Prime – Up to five (5) specialty service contracts

As a result of the RFSQ, seven (7) firms were selected to perform various A&E services. For projects requiring A&E Services, work orders will be issued to these firms.

On January 12, 2024, MTS staff issued a Request for Proposals to all A&E firms in Categories A & B.

On February 14, 2024, MTS received one proposal from CRA (the other on-call firms that received the solicitation chose not to submit a proposal). On March 6, 2024, MTS issued a post bid survey to attempt to ascertain why the other on-call firms did not provide proposals for the project. MTS did not receive any responses to this request. Thus, and after reviewing the scope of services, MTS staff determined that the solicitation, as issued, did not contain language that would have restricted participation, and proceeded with evaluation of the single proposal from CRA.

On March 8, 2024, an MTS evaluation panel consisting of Real Estate and Finance conducted its initial evaluation of CRA's proposal and awarded it the following score:

Ranking	Proposer Name	Total Score
1	CRA	89.34

However, MTS determined that additional information was needed from the proposer to clarify their technical submission. Thus, on March 19, 2024, the evaluation committee scored CRA's revised technical proposal and awarded it the following score:

Ranking	Proposer Name	Total Score
1	CRA	92.01

As part of this evaluation, the evaluation panel concluded that CRA met the standards of being the “most qualified” A&E firm to provide the specified services.

For this project CRA will utilize the following subconsultants:

Subconsultant Name	Certification	Subconsultant Amount
Epic Land Solutions, Inc.	None	\$503,364.06

CRA’s initial proposed amount for the services was \$599,177.17. Through negotiations, staff was able to reduce this amount by \$65,728.87. Based on the level of effort and proposed classifications, CRA’s final cost proposal in the amount of \$533,448.30 was determined to be fair and reasonable.

Therefore, staff recommends that the MTS Board of Directors authorize the CEO to execute Work Order WOA357-AE-39 under MTS Doc. No. PWL357.0-22 (in substantially the same format as Attachment A), with CRA, a DBE, in the amount of \$533,448.30 to provide tenant relocation and property management services for the CTAC project.

/s/ Sharon Cooney  
Sharon Cooney  
Chief Executive Officer

Key Staff Contact: Julia Tuer, 619.557.4515, [Julia.Tuer@sdmts.com](mailto:Julia.Tuer@sdmts.com)

Attachment: A. Draft Work Order, MTS Doc. No. WOA357-AE-39



# Metropolitan Transit System

April 25, 2024

MTS Doc. No. PWL357.0-22  
WOA357-AE-39

Mr. Ross Duenas, PE  
Executive Vice President/Principal  
CR Associates  
3900 Fifth Avenue, Suite 310  
San Diego, CA 92103

Dear Mr. Duenas:

Subject: WORK ORDER WOA357-AE-39, TO MTS DOC. NO. PWL357.0-22, CLEAN TRANSIT  
ADVANCEMENT CAMPUS (CTAC) TENANT RELOCATION AND PROPERTY  
MANAGEMENT SERVICES

This letter shall serve as Work Order WOA357-AE-39, under the General Engineering Consultant Agreement, MTS Doc. No. PWL357.0-22, as further described below.

## SCOPE OF SERVICES

This Work Order shall provide relocation services and property management services for tenants located at 4506-4520 Federal Blvd for the CTAC Real Estate Acquisition Tenant Relocation Services project. (Attachment A and A1).

## SCHEDULE

The Scope of Services, as described above, shall be for a period of forty-two (42) months from the date of the Notice to Proceed.

## PAYMENT

Payment shall be based on actual costs in the amount not to exceed \$533,448.30 without prior authorization of MTS (Attachment B).



Please sign below, and return the document to the Contracts Specialist at MTS. All other terms and conditions shall remain the same and in effect.

Sincerely,

Accepted:

Sharon Cooney  
Chief Executive Officer

\_\_\_\_\_  
Ross Duenas, PE  
Executive Vice President/Principal

Date: \_\_\_\_\_

Attachments: Attachment A, Scope of Services  
Attachment A1, Consultant's Proposal  
Attachment B, Negotiated Fee Proposal

DRAFT



**ATTACHMENT A  
SCOPE OF SERVICES**

DRAFT

**TITLE: CTAC Real Estate Acquisition Tenant WOA #: WOA357-AE-36  
Relocation Services**

**I. PROJECT DESCRIPTION**

This work order shall consist of relocation services for tenants located at 4506-4520 and 4550 Federal Blvd for the CTAC Real Estate Acquisition Tenant Relocation Services project.

**II. SCOPE OF WORK**

The scope of work shall consist of the following tasks and deliverables:

**Task 1 – Project Management and Coordination**

- 1.1 Provide project management services including the requirements for invoicing, scheduling, monthly project progress reports, and administration of the Consultant's team.
- 1.2 Provide project coordination with MTS as well as coordination with other project stakeholders as necessary.
- 1.3 Provide coordination and oversight of subconsultant(s) and integration of plans and specifications into submittal packages.
- 1.4 Also included in Project Management is QA/QC which will be performed on all deliverables. To ensure quality of work and compliance with the scope of work, the consultant shall perform a systematic in-house review of all documents produced prior to submittal. All reviewed documents will have a check box or signature page indicating review has been performed.

**Task 2 - Prepare Relocation Plan**

Consultant shall draft a Relocation Plan (Plan) that considers all seventeen (17) tenant relocations and three (3) personal property moves displaced by the project (Exhibit A). The Plan analyzes their relocation options, anticipates all costs, and outlines the needs of business owners and plan for claim disbursements. The Plan will also verify the feasibility of anticipated relocations and forms an itemized project budget, including moving expenses. To prepare the Plan, Consultant may interview displacees to understand challenges and better estimate relocation costs. The Plan will be prepared in accordance with state guidelines, rules, and regulations, in accordance with the Uniform Act and California Code of Regulations Title 25, § 6038. Upon completion, the draft Plan will be provided to MTS for review and approval.

**2.1 Occupant Interview and Notices**

Consultant shall prepare the following notices and conduct an intake interview with each business occupant impacted by this project:

- a. General Information Notice (GIN)
- b. Business Interview Form
- c. Informational Brochure
- d. Certificate of Lawful Presence
- e. Notice of Eligibility (NOE)—Non-Residential/Business Occupant
- f. 90-Day Notice to Vacate [required by federal law]
- g. 60/30-Day Notice to Vacate [as necessary, per AGENCY preference]

Consultant shall contact the authorized representative of each business and explain the relocation assistance program and eligibility requirements for relocation payments to impacted business owners and tenants. Consultant shall maintain a diary of relocation details and communications, capturing all salient conversations, discussions, emails, and other pertinent information with

owners/ representatives. During the interview, the Consultant will also request a copy of the lease agreement, as needed.

## **2.2 Present and Offer Fixtures and Equipment (F&E) Appraisal**

For all property improvements constructed by the Lessee and/or Business Occupants, a Fixtures and Equipment (F&E) appraisal will be conducted as part of the right of way acquisition process (performed by others), estimated at 16 appraisals. Consultant shall review the F&E appraisals for accuracy/consistency checks and provide copies to the owner and tenant with all valuations redacted. Consultant shall assist in resolving tenant/landlord issues and issues with how compensation to be paid between landlord and tenant.

## **2.3 Relocation Assistance Advisory Services**

All business tenants who may be eligible for relocation entitlements must have their rights fully defined and understood as early as possible in the process. As part of advisory assistance, it is important to establish a clear line of communication with the displaced tenants. Consultant shall provide the following services during the Relocation Process:

- a. Thoroughly explain relocation entitlements to the tenants per Federal and California State Regulations.
- b. Relocation advisory assistance (identifying suitable replacement sites and provide referrals for displacees, review lease agreements for replacement site)
- c. Secure move bids (fixtures and equipment movable and non-movable for occupants).
- d. Process claims for displacees (fixed moving payment claim for occupants; relocation assistance claim for tenant and/or owner occupant; deliver payments)
- e. Moving/reestablishment/searching or fixed payment in-lieu of actual moving and related expense claim for business occupant
- f. Provide *Certificate of Abandonment* to landlord to conduct vacancy inspection/final walkthrough.

## **2.4 File Close-Out & Documentation**

Consultant shall prepare the final relocation package for submittal to MTS to commence the process for document review and requesting of relocation funds. Such package shall include but not be limited to: (i) all original documents signed by occupants; (ii) diary; and (iii) other relevant relocation information. Such documentation shall be on MTS preferred forms unless otherwise permitted.

## **Task 3 – Property Management**

Consultant will be responsible for typical commercial property management responsibilities, including but not limited to the following:

1. Rent collection and submission to MTS
2. Tenant management
3. Normal and regular building maintenance either directly or indirectly via licensed and bonded contract companies
4. Security
  - a. During tenant occupancy and post occupancy until demolition
  - b. Adding fencing and gates as necessary
  - c. Securing of vacant buildings (i.e. boarding of windows, changing locks, adding security gates, plumbing shut-off valves, plumbing capping, etc.)
  - d. Posting of guards or installation of security systems/cameras as necessary
5. Vector control

6. Utility billing close out and transfer to MTS upon tenant vacating premises
7. Graffiti removal
8. Other duties typical with commercial property management

**III. PERIOD OF PERFORMANCE**

The period of performance shall be forty-two (42) months from the date of the Notice to Proceed. Consultant shall provide their services as expeditiously as practicable to meet a mutually agreed-upon schedule.

**IV. DELIVERABLES**

1. Relocation Plan (as needed)
2. Intake interview questionnaire
3. Required notices
4. Present and Offer Fixtures and Equipment (F&E) Appraisal to tenants
5. Process entitlement claims
6. Final vacancy inspection (Certificate of Abandonment)

**V. SCHEDULE OF SERVICES/MILESTONES/DELIVERABLES**

A. Tasks Schedule

<b>Task</b>	<b>Begin/End Dates</b>
Relocation Plan	NTP / NTP +12 months
Tenant Interviews	NTP / NTP + 6 months
Present Fixture & Equipment Appraisal to Tenants	NTP / NTP + 12 months
Relocation Assistance	NTP / NTP + 42 months
Property Management	Month 30 / Month 42

B. Milestones/Deliverables Schedule

<b>Milestone/Deliverable</b>	<b>Due Date</b>
Tenant Interview Completion Summary	NTP + 6 months
Relocation Plan	NTP + 12 months
Present Fixture & Equipment Appraisal to Tenants	NTP + 12 months
File Closeout Documentation	NTP + 42 months

**VI. MATERIALS TO BE PROVIDED BY MTS AND/OR THE OTHER AGENCY**

Title reports, Real Property Appraisals, Tenant Contact Information

**VII. ASSUMPTIONS**

- 1 Assumes seventeen (17) non-residential occupants and three (3) personal property only are permanently displaced from their current locations.
- 2 Assumes the project involves federal funding.
- 3 Assumes property owner is eligible for relocation assistance and this case is part of the fees for the 20 non-residential occupants.

- 4 Fixtures and Equipment (F&E) appraisals will be provided by others. Consultant shall coordinate between non-residential occupant and client/property owner Statement of Ownership. Consultant shall prepare offer packages and Bill of Sale/Tenant Seller Agreements. Consultant shall only provide loss of business goodwill notice/questionnaire.
- 5 Loss of Business Goodwill Appraisals and lease bonus value analysis; if required, shall be provided by others. Consultant labor costs for coordinating these appraisal services are not included in the fee.
- 6 Assumes project has no delays and that the scope of work described herein can be completed with forty-two (42) months of Notice to Proceed (NTP).
- 7 All meetings with client and Agency will be virtual, up to 42 meetings no more than half an hour each meeting.
- 8 Up to 42 project status reports will be provided to client and Agency.
- 9 Consultant shall conduct the non-residential interviews and provide/explain relocation brochure to displacees in-person.
- 10 Consultant shall provide relocation notices and claim form templates.
- 11 Assumes Consultant shall conduct no more than 3 claims for each of the 17 non-residential occupants and 1 claim for the three personal property move only for non-residential occupants.
- 12 Assumes Replacement Housing Plan is not necessary for this project as no residential relocations are planned.
- 13 No interim property management services are included but can be provided for a separate fee.
- 14 Assistance for unlawful detainer is not included. Deposition, court testimony and expert witness fees are additional, to be compensated on a time and materials basis.
- 15 Assumes Consultant shall issue twenty (20) Notice of Eligibility (NOE).
- 16 Assumes Consultant may execute tenant estoppals; if needed, for separate fee since it is part of property management.
- 17 Assumes Client/Agency will obtain rent roll from property owner prior to non-residential tenants vacating and provide copy to Consultant.
- 18 Assumes Consultant shall not process any loss rents agreements and will only provide rent information provided by non-residential occupant to Client/City.
- 19 Assumes Consultant shall provide assistance during the appeal process for a separate fee not included in this proposal. And Agency has an appeal process in place.
- 20 Assumes Agency has appeal process in place prior to any NOE issuance to any displacee.
- 21 Assumes no interpretation services needed and no documents are needed in another language; if needed, Consultant can obtain for additional fee.
- 22 Assumes relocation plan has no residential displacements to be considered.
- 23 Assumes non-residential occupant with NOE for personal property move only has no fixtures and equipment (F&E).
- 24 Assumes check delivery for claims will be coordinated by Consultant via mail only.
- 25 Assumes Consultant agents will make 2 trips for each of the 20 non-residential occupant to project site within 42 months of project duration which includes in-person visit to conduct interview and explain relocation benefits.
- 26 Assumes Consultant project manager will make 2 trips to project site within 42 months of project duration.
- 27 Assumes tenant-seller agreements will be prepared and coordinated for a separate fee.
- 28 Assumes bulk sales and UCC search will be conducted by others.

**VIII. MTS ACCEPTANCE OF SERVICES:**

Contractor shall not be compensated at any time for unauthorized work outside of this Work Order. Contractor shall provide notice to MTS' Project Manager upon 100% completion of this Work Order. Within five (5) business days from receipt of notice of Work Order completion, MTS' Project Manager shall review, for acceptance, the 100% completion notice. If Contractor provides final service(s) or final work product(s) which are found to be unacceptable due to Contractors and/or Contractors subcontractors negligence and thus not 100% complete by MTS' Project Manager, Contractor shall be required to make revisions to said service(s) and/or work product(s) within the Not to Exceed (NTE) Budget. MTS reserves the right to withhold payment associated with this Work Order until the Project Manager provides written acceptance for the 100% final completion notice. Moreover, 100% acceptance and final completion will be based on resolution of comments received to the draft documents and delivery of final documentation which shall incorporate all MTS revisions and comments.

Monthly progress payments shall be based on hours performed for each person/classification identified in the attached Fee Schedule and shall at no time exceed the NTE. Contractor shall only be compensated for actual performance of services and at no time shall be compensated for services for which MTS does not have an accepted deliverable or written proof and MTS acceptance of services performed.

**IX. DEFICIENT WORK PRODUCT**

Throughout the construction management and/or implementation phases associated with the services rendered by the Contractor, if MTS finds any work product provided by Contractor to be deficient and the deficiently delays any portion of the project, Contractor shall bear the full burden of their deficient work and shall be responsible for taking all corrective actions to remedy their deficient work product including but not limited to the following:

- Revising provided documents,

At no time will MTS be required to correct any portion of the Contractors deficient work product and shall bear no costs or burden associated with Contractors deficient performance and/or work product.

**X. DELIVERABLE REQUIREMENTS**

Contractor will be required to submit any and all documentation required by the Scope of Work. The deliverables furnished shall be of a quality acceptable to MTS. The criteria for acceptance shall be a product of neat appearance, well-organized, and procedurally, technically and grammatically correct. MTS reserves the right to request a change in the format if it doesn't satisfy MTS's needs. All work products will become the property of MTS. MTS reserves the right to disclose any reports or material provided by the Contractor to any third party.

Contractor shall provide with each task, a work plan showing the deliverables schedule as well as other relevant date needed for Contractor's work control, when and as requested by MTS.

Contractor's computer data processing and work processing capabilities and data storage should be compatible with Windows compatible PC's, text files readable in Microsoft Word, and standard and customary electronic storage. Contractor shall maintain backup copies of all data conveyed to MTS.

Contractor shall provide MTS with hard copy or electronic versions of reports and/or other material as requested by MTS.

**XI. PRICING**

Except where otherwise noted herein, pricing shall be firm and fixed for the duration of the Work Order and any subsequent Change Orders/Amendments to the Work Order. Other direct expenses will be invoiced at cost. There shall be no escalation of rates or fees allowed.

**XII. ADDITIONAL INFORMATION**

Any services not specifically described in the above scope, as well as any changes in the scope the Client requests, will be considered Additional Services and will be performed at our then-current hourly rates. Prior to commencing the Additional Services, the Consultant shall obtain prior written approval from the Client.

**XIII. PREVAILING WAGE**

Prevailing wage rates apply to certain personnel for these services?  Yes  No

DRAFT

## Exhibit A

#	Street Address	Business Name	Type of Business	Notes
1	4506-4520 Federal Boulevard			
1	4506 Federal Blvd	All Pro Stickers	Car Wraps, Building Advertisement	10,000SF shop - per website
2	4506 #A Federal Blvd	Brooke Paper Scissors		
3	4506 #B Federal Blvd	H&H Diversified Investment Co. Inc	Owner's office	
4	4506 #D Federal Blvd	Drop Kick Brew	Coffee Distributor / wholesaler	
5	4510 Federal Blvd	San Diego Scale		
6	4514 Federal Blvd	Cal Auctions	Aution House	Looks like they have an auto workshop as well
7	4514 #D Federal Blvd	Sanwood Fine Carpentry & Construction Inc.	General contractor, Remodels and renovations	
8	4514 #D Federal Blvd	L Electric (Sub to Sanwood)		
9	4520 #A Federal Blvd	Half Off Wholesale	Wholesaler	Open warehouse, can see picture of inside from their website
10	4520 #B Federal Blvd	Accessories Plus Fabrication		
11	4520 #C Federal Blvd	Pro-Active Concrete	Concrete services - New Construction / repairs	



## Exhibit A

#	Street Address	Business Name	Type of Business	Notes
<b>2</b>	<b>4570-4586 Federal Boulevard</b>			
12	4576 Federal Blvd	Mixed Media Art Gallery and Studio	Art Studio	
13	4582 & 4584 Federal Blvd	Antonio's Metal Works, Inc	Metal Fabricator	
14	4582 Federal Blvd	Iron Welding International (Sub to Antonios)		
15	4582 Federal Blvd	One Stop Metal Fabrication (Sub to Antonios)		
16	4582 Federal Blvd. #A	Robb's Security Bars and Fencing		
17	4586 Federal Boulevard	Vacant Building and Lot		
18	Action Gypsum	Personal Property Storage of Misc		
<b>3</b>	<b>4550 Federal Boulevard</b>			
19	4550 Federal Boulevard	Distribution International	Commercial and Industrial Insulation	
			<a href="https://www.distributioninternational.com/">https://www.distributioninternational.com/</a>	
	<i>Note: all info for 4550 Federal is from sidewalk views and information available on the internet. MTS letters have not been answered.</i>			

Total

17 relocations

3 personal prop moves

**ATTACHMENT A1  
CONSULTANT'S PROPOSAL**

DRAFT



3900 5th Avenue, Suite 310  
San Diego, CA 92103

# PROPOSAL



Innovative  
Solutions  
for  
MTS

SAN DIEGO  
METROPOLITAN  
TRANSIT  
SYSTEM  
(MTS)

**A&E MASTER AGREEMENT AWARDS FOR CLEAN  
TRANSIT ADVANCEMENT CAMPUS (CTAC) TENANT  
RELOCATION SERVICES**

WOAXXX-AE-39

A-13



# Table of Contents

Cover Letter . . . . .1

1. Project Team . . . . .2

2. Project Teams Capabilities . . . . .6

3. Project Understanding and Approach . . . . .9

4. Schedule . . . . .14

5. DBE Subcontractor Utilization Plan . . . . .15

6. Exceptions/Deviations to RFP . . . . .15

Exhibit A - Resumes

Exhibit B - Refined Impact Table

DRAFT



# Cover Letter

March 13, 2024

Attention: **Steve Augustyn, Contract Officer**



San Diego Metropolitan Transit Systems (MTS)  
1255 Imperial Avenue, Suite 1000  
San Diego, CA 92101-7490

RE: A&E Master Agreement Awards for Clean Transit Advancement Campus (CTAC) Tenant Relocation Services

Dear Mr. Augustyn and Members of the Evaluation Panel:

CR Associates (CRA) is enthusiastic about the opportunity to present this proposal for the San Diego Metropolitan Transit System (MTS) Clean Transit Advancement Campus (CTAC) Non-Residential Tenant Relocation Services project (WOAXXX-AE-39) in coordination with our primary subconsultant, Epic Land Solutions, Inc. (EPIC). Our team will provide comprehensive project management, relocation plan, relocation assistance services, and interim property management services for the proposed CTAC—a new bus maintenance and charging facility for electric buses that will support MTS in adding a sixth bus division in the Ridgewood and City Heights neighborhoods and expand its clean fleets. This proposal presents the following benefits for MTS to make the CTAC project a success:

**COLLABORATIVE TEAM.** Project Managers at EPIC and CRA have collaborated on various projects in San Diego and greater Southern California. With CRA as your trusted project manager and project leader, and EPIC as your relocation specialist, MTS can be confident that this hybrid team has the proper experience, expertise, and immediate availability to kick-off and deliver comprehensive relocation services within your timeline goals. You can expect CRA's project management to be comprehensive, consistent, and clear. The EPIC relocation manager will guide and advise MTS through all stages of the relocation process to make complex elements achievable.

**RELOCATION SPECIALISTS.** EPIC is an industry leader in the provision of comprehensive relocation services, including relocation plan preparation, noticing, replacement site identification for non-residential displacements, and interim property management services. Recent experience includes six non-residential relocations for SANDAG Downtown Bus Stopover Improvements project, creating a Relocation Plan approved by FTA and initiating relocations for 44 businesses for the City of Inglewood's fixed guideway Transit Connector project, and 18 relocation files and interim property management for San Bernardino County Transportation Commission's zero-emission West Valley Connector BRT project — We are eager to put our proven best practices to work for this CTAC project.

**SERVICES BUILT FOR SELF-HELP COUNTIES.** CRA and EPIC have extensive experience delivering design and relocation assistance services for Southern California's self-help county transportation agencies, with active contracts and extensive project history with SANDAG, NCTD, OCTA, SBCTA, LA Metro, and RCTC. Our services are built to support transit agencies and transportation authorities achieve infrastructure improvements in accordance with prevailing guidelines, including the Uniform Act, to obtain critical oversight agency approvals and protect project funding sources.

We look forward to working with the MTS team to make the tenant relocations for CTAC a resounding success!

Sincerely,

CR ASSOCIATES

**Ross Duenas, PE**

Principal-In-Charge/Contract Manager

EPIC LAND SOLUTIONS, INC.

**Karen Starr, CPM, SR/WA**

EPIC Senior Vice President/Authorized Signatory



# 1. Project Team

## Staffing Plan

CRA has assembled leading experts on relocation services in San Diego to provide services to MTS for the CTAC project to move forward successfully. CRA, EPIC, and Joshua Grading have all supported San Diego region and other Southern California region agencies with comprehensive project management, relocation assistance, and property management services. Our team brings understanding of MTS's project expectations and areas of concern or uncertainty; our goal through this project is to be reliable partner you can turn to as we progress on relocations, with everyone of our staff aligned to your project goals and available to discuss detailed project matters with you as needed.

Our team has an in-depth understanding of relocation laws and regulations, including but not limited to the Uniform Relocation Assistance and Real Property Acquisition for Federal and Federally Assisted Programs (Uniform Act), California Government Code Title 1, Chapter 16, Sections 7260-7277, Relocation Assistance Law and California Government Code Title 25, Division 1, Chapter 6, Sections 6000-6198, California Relocation Assistance and Real Property Acquisition Guidelines.

## About CR Associates



CR Associates was founded in 2011 as a woman-owned business that focuses on delivering high quality transportation projects for

local agencies and communities. We are based in San Diego and Los Angeles, with 45+ employees. We are committed to planning and designing transit and transportation systems and mobility improvements that create and support vibrant and sustainable communities. We provide a complete, multi-modal approach, building upon the multidimensional experiences of our staff, along with our dedication to serving the full range of Client needs. We understand the quality-of-life and health benefits of integrated transportation/land use planning, smart growth and active transportation, and are committed to ensuring projects have the least impact and most benefit to our communities. Our strong technical expertise and practical experience allow us to execute a wide range of transportation projects and take them from paper to pavement. Our staff are proven industry experts in their respective fields, enabling us to provide the full spectrum of services required under this task order.

## About Epic Land Solutions, Inc.



Epic Land Solutions, Inc. (EPIC) is a full-service relocation assistance and real property consulting services firm with local office in San Diego and headquarters in Torrance. The

firm was founded as a C Corporation in 2000 and has served public agencies in Southern California for over 23 years. The relocation and property management specialists at EPIC have provided transit-oriented development service consulting for multiple regional transit and transportation agencies, including North County Transit District, Los Angeles County Metropolitan Transportation Authority, California High-Speed Rail Authority, Riverside County Transportation Commission, and San Bernardino County Transportation Agency. The firm's philosophy is "creating land solutions for the public good," which we are excited and confident for the contributions these tenant relocations will make on increasing availability of transit capacity to this southeastern portion of San Diego. While the firm manages their projects locally, they are able to tap into an entire network of resources from both internal EPIC staff of over 60 professionals as well as their parent company, CLS, Family of Companies with over 900 professionals nationwide. This provides increased staffing power, expert knowledge, and financial backing to deliver comprehensive relocation assistance services to their clients, including MTS.

## Property Maintenance Subconsultants, As Needed



Joshua Grading & Excavating incorporated in 2003 and is a General Engineering Contractor. Currently, Joshua Grading employs over 80 staff throughout Southern California. As an

industry leader, Joshua owns and operates trucks and machinery currently used for their numerous contracts. They have right of way maintenance contracts with OCTA, RCTC, and SBCTA. They also currently assist Epic Land Solutions, Inc. on their property maintenance contracts with multiple Southern California county agencies. In addition, Joshua recently signed contracts with RCTC for their Station Maintenance Projects and OCTA for their On-Call Property Maintenance and Related Services contract. Recently, the firm assisted Metrolink with removing two bridges in San Clemente that were affected by a mudslide that slid down a hill effecting the safety of the track and stopping transit in that area. Joshua Grading has over 20 years' experience and is known for their excellent safety record, and exceptional job performance throughout California, Arizona, Utah, and Nevada.



Apex Construction is a leading construction company providing high-quality services to residential and commercial customers. They

specialize in commercial projects, residential remodels, repairs, and maintenance. Their team of experts has over 20 years of experience in the industry and is dedicated to delivering excellent workmanship and customer satisfaction. Apex Construction approaches every project with integrity, honesty, and attention to detail. Their commitment to excellence is reflected in the quality of their work.

## Project Experience Highlights

### Downtown Bus Stopover

SANDAG | San Diego, CA | 2023 - Ongoing

SANDAG sought to complete acquisitions for a block they already partially owned between State Street, Union Street, A Street, and B Street to construct a multiuse and **bus stopover facility in Downtown San Diego**. The proposed facility will provide an off-street location where transit vehicles can be parked for short periods between runs. In addition to the stopover, the facility has the potential to provide future office space for SANDAG and other tenants as part of a

Transit Oriented Development (TOD) including office, retail, and housing, including affordable housing. A maximum of two full-takes were identified, with a maximum of **six (6) non-residential relocations**. The EPIC team, including several proposed members for the CTAC project, is responsible for all relocation services on the project, including relocation plan, tenant interviews and notices, relocation assistance services, and final close-out documentation (including Certificate of Abandonment).

### Inglewood Transit Connector

City of Inglewood | Inglewood, CA | 2022 - Ongoing

The ITC is a 1.6-mile (2.6 km) fully elevated, automated guideway transit system proposed in Inglewood, California that will connect the Downtown Inglewood station on the K Line of the Los Angeles Metro Rail system to nearby major sports and entertainment venues. To kick off the project, **Senior Project Manager, Eddie Quintero, drafted the Relocation Plan for the project that was approved by the Federal Transit Administration (FTA) for the project**. As part of the ongoing pre-acquisition planning tasks, EPIC is preparing Relocation Claim Forms for the **estimated 44 impacted tenants** while also reviewing and providing comments to the Appraisal Policy and Procedures, Acquisition Policies and Procedures, and Relocation Policies and Procedures for the ITC project. EPIC has also attended meetings and made presentations representing the City at public hearings.

### West Valley Connector BRT Corridor

SBCTA | Ontario, CA | 2021 - Ongoing

EPIC was contracted for Segment 4 for **bus rapid transit improvements for over 19 miles of roadway**. Due to the dedicated bus lane design in this section, 10 of the 56 larger parcels impacted will be acquired as full takes, resulting in **25 relocation assistance cases (consisting of 17 businesses and 8 residential displacements)**. Properties impacted included small businesses, motels, restaurant franchises with vehicle drive-thru access, gas stations, auto repair, and auto dealers. The team is now performing interim property maintenance and management tasks, including coordination of hazardous materials testing, abatement, and demolition coordination to clear project sites and prepare the parcels for construction. Tasks involve asbestos testing and abatement, contractor requests for bids, bid selection, contractor performance oversight, fencing/board-up, and utility shut-off for gas, water, electric.

## Organizational Chart

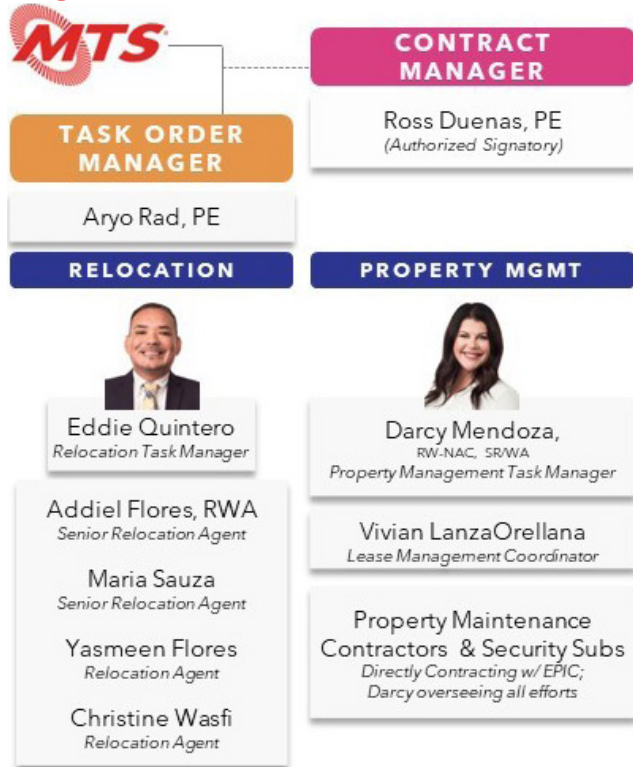

## Key Staff

### Ross Duenas, PE Contract Manager (CRA)

Ross has 18 years of experience designing and managing transportation and public works projects for public agencies. Over the last decade, Ross has designed tens of millions of dollars of construction documents throughout San Diego County. This experience equips him to bring unique insights into the constraints and opportunities required for the appropriate use of local and regional engineering standards.



### Aryo Rad, PE Task Order Manager (CRA)

Aryo brings more than two decades of civil engineering experience with a successful track record of leading complex multidisciplinary transportation and transit projects. He has worked with more than 50 regional transit and transportation agencies, assisting with transportation and transit projects. As Task Order Manager, Aryo will provide oversight to all deliverables for this task order.



### Eddie Quintero Relocation Task Manager (EPIC)



Eddie is a Senior Relocation Project Manager who has built the last 12+ years of his career managing and performing relocation assistance services on behalf of major public agencies throughout Southern California, including Los Angeles County Metropolitan Transportation Authority, Orange County Transportation Authority, and various municipalities. He is a talented team leader, organized project manager, and committed custodian of prevailing regulations as defined by the Uniform Act and State of California. Eddie has a formal education in Urban and Environmental Planning and served as an Associate Planner for the City of Taft in Kern County. More recently, Eddie managed several complex relocation cases for commercial and industrial uses displaced by the Metro D Line and Gerald Desmond Bridge Replacement. He has completed over 500 temporary and permanent residential relocations throughout his career. **As Relocation Task Manager for the MTS CTAC project**, Eddie will be responsible for comprehensive oversight of the relocation process, including Relocation Plan, tenant interviews, F&E appraisal offers, relocation assistance, and file close-out documentation.

### Darcy Mendoza, SR/WA, R/W-NAC Property Management Task Manager (EPIC)



Darcy is an Assistant Regional Manager with over 20+ years of experience that has been involved in all aspects of right of way project management, including quality assurance and oversight for property management and relocation services. Prior to EPIC, she was a Title & Escrow Officer for a diverse range of customers throughout Southern California and has a strong understanding of complexities related to real property transacting. Darcy has provided long-term and interim property management services for over 500 properties acquired by RCTC and SBCTA over the past few years, coordinating a wide variety of tasks including collection of rent, lease and license management, and routine inspections. **As Property Management Task Manager for the MTS CTAC project**, Darcy will oversee all property management tasks including rent collection, lease management, site security, property maintenance, and proactive problem solving for any property management challenges that may arise.



**Addiel Flores, RWA**

Senior Relocation Agent (EPIC)



Addiel is a relocation professional with over 10 years of experience transacting real estate and performing relocation assistance on behalf of public agencies throughout Southern California. He has extensive experience locating suitable replacement business sites and housing throughout multiple states for displaced tenants - performing 500+ temporary and permanent relocations in the span of his career. Addiel has supported some of EPIC’s largest relocation projects, including the Inglewood Transit Connector, granting him a wealth of understanding for relocation assistance procedures and requirements. Addiel is a veteran of the United States Army, having served from August 2000 through February 2012. **As a Senior Relocation Agent for the MTS CTAC project**, Addiel will provide direct boots-on-the-ground relocation assistance services including tenant interviews and notices, presentation of F&E appraisals, relocation assistance communications with tenants, and additional support, as needed.

**Maria Souza**

Senior Relocation Agent (EPIC)



Maria is a seasoned real estate broker and relocation assistance agent with 20+ years of experience who has excelled as a successful negotiator, treating all stakeholders with respect and ensuring that all paperwork is completed on-time and properly filed. She has worked with a variety of clients throughout Southern California including transportation agencies, municipalities, and housing authorities. Maria has completed over 550 relocations throughout her career. **As a Senior Relocation Agent for the MTS CTAC project**, Maria will support relocation assistance services through thorough documentation maintenance, tenant interview and notice support, and additional support, as needed.

**Yasmeen Flores**

Relocation Agent (EPIC)



Yasmeen is a highly organized and driven Relocation Agent with 4+ years of experience who excels at problem solving, concise communication, and team collaboration for efficient production of client deliverables. She relies on her technical abilities to provide analysis and research on

right of way utilizing GIS and Archibus to complete her research. Yasmeen uses her strong communication skills to provide translation services and create solutions to overcome language barriers in her negotiations. She excels at leading and supporting teams to ensure the scope of work is accurately carried out. Yasmeen has successfully completed over 175 relocations in her career. **As a Relocation Agent for the MTS CTAC project**, Yasmeen will provide direct boots-on-the-ground relocation assistance services including tenant interviews and notices, presentation of F&E appraisals, relocation assistance communications with tenants, and additional support, as needed.

**Christine Wasfi**

Relocation Agent (EPIC)



Christine Wasfi is a Relocation Agent with 10+ years of experience who is a talented negotiator, working professionally and patiently with property owners from various backgrounds to resolve conflicts, questions, and reach voluntary settlements. Due to her background in real estate, Christine easily navigates real estate market research, transaction details, and has a strong command of documentation best practices. Her growing portfolio of experience includes relocation services for a myriad of clients, including supporting EPIC’s Inglewood Transit Connector and West Valley Connector projects. **As a Relocation Agent for the MTS CTAC project**, Christine will support relocation assistance services through thorough documentation maintenance, tenant interview and notice support, and additional support, as needed.

**Vivian LanzaOrellana**

Lease Management Coordinator



Vivian is an exemplary administrative professional with 9+ years of experience in supporting management and operation teams within demanding work environments. She has provided extensive document maintenance on some of EPIC’s largest property management contracts and beyond, overseeing hundreds of documents regularly. **As Lease Management Coordinator**, Vivian will support property management efforts with direct oversight of all tenant leases/insurance, coordination of new leases/insurance, data entry, and efficient file management..

## 2. Project Teams Capabilities

### Project Management & Communication

Our team recognizes the importance of providing effective project controls to deliver projects on schedule and within budget. Upon initiation of the task order, CRA's team will organize a kick-off meeting with MTS project manager to confirm the project schedule and goals, discuss our approach for executing the scope of work and deliverables, identify any specific project's needs, and affirm the desired level of communications and norms of project management to be maintained over the course of the project. From there, **CRA's team and EPIC's technical task leads will organize regular meetings or calls with the MTS project manager and any other relevant stakeholders to keep them informed on the progress of the project's ongoing and remaining tasks.** With each monthly invoice, CRA will submit a progress report according to the requirements of the MTS which documents the work completed for that period to ensure accountability to the project schedule and budget.

In addition to scheduled project management meetings, our contract manager and task order manager are available to MTS team by cell phone and email 24-7. This commitment to maintaining open lines of communication will ensure project questions and inquiries are resolved in a timely manner, and that the project schedule is upheld. We offer streamlined collaboration through the use of virtual meetings and document sharing software such as Teams, Zoom and SharePoint.

As a **service provider specializing in on-call contracts, EPIC is all very skilled at handling variable project schedule demands and expectations.** EPIC will maintain frequent and consistent communication with MTS and CRA so that you may turn to them as a reliable technical project partner for CTAC project goals through well defined project specifics and goals at kick-off, reliably consistent progress reports, and prompt response to project concerns.

### Current Commitments & Availability

The success of the CTAC tenant relocations is of prime importance to our team. The personnel assigned to lead and deliver this project were hand-picked due to their relevant project experience and availability to provide availability to the MTS team for the CTAC tenant relocation project:

Key Personnel	Current Assignments	Availability	Anticipated Hours Per Week Commitment to CTAC Project
Ross Duenas <i>Contract Manager</i>	MTS   TPSS – 5% SANDAG   University Bike Lane – 20%	15%	Approx. 1+ hours
Aryo Rad <i>Task Order Manager</i>	MTS   TPSS - 10% City of South El Monte   Civic Center Bike Lanes – 30%	25%	Approx. 2+ hours
Eddie Quintero <i>Relocation Task Manager</i>	City of Inglewood   Inglewood Transit Connector – 10% LA Metro   C Line Extension to Torrance (GLET) – 15%	75%	Approx. 10+ hours
Darcy Mendoza <i>Property Management Task Manager</i>	RCTC   Property Management On-Call – 15% SBCTA   West Valley Connector BRT – 5%	80%	Approx. 15+ hours
Addiel Flores <i>Senior Relocation Agent</i>	SANDAG   Downtown Bus Stopover Relocations – 15% OCTA   I-5/Oso Pkwy Non-Residential Relocations – 10%	75%	Approx. 20+ hours
Maria Sauza <i>Senior Relocation Agent</i>	Matrix Renewables   CAISO BESS Campaign – 15%	85%	Approx. 10+ hours
Yasmeen Flores <i>Relocation Agent</i>	SANDAG   Downtown Bus Stopover Relocations – 15% LA Metro   C Line Extension to Torrance (GLET) – 10%	75%	Approx. 20+ hours
Christine Wasfi <i>Relocation Agent</i>	City of Inglewood   Inglewood Transit Connector – 10% RUSD   Property Management Park Ave – 5%	85%	Approx. 10+ hours
Vivian LanzaOrellana <i>Lease Management Coordinator</i>	RCTC   Property Management On-Call – 15% SBCTA   West Valley Connector BRT – 5%	80%	Approx. 20+ hours

## Quality Control/Quality Assurance Procedures

CRA is passionate about providing quality services and products. We were founded on a commitment to fostering a workplace culture dedicated to delivering products that are accurate, well-written, based on sound reasoning and assumptions and have been thoroughly reviewed by senior staff before submission. We have the policies and procedures in place to ensure that our team delivers a quality product every time. We acknowledge that quality and schedule can compete, and for us, quality always wins. Because of this fact, our internal project schedules include time dedicated to formal quality control prior to each submittal. We take our engineering responsibility seriously, and **before stamping and signing deliverables we ensure that the quality control process has been completed and documented.** It takes more than just the quality assurance and quality control program detailed above. High quality deliverables require experience, knowledge, innovation, cooperation, and creativity.

### QC CHECKPOINTS



Specific to Relocation and Property Management Services, **EPIC's QA/QC procedures will work in tandem with CRA's, providing comprehensive project structure and organization of all documentation.** All EPIC projects are guided by a QA/QC Plan that has been developed, tested, and proven through their 23 years delivering relocation and property management projects for public agencies. **EPIC's QA/QC procedure relies on a three-tiered approach** that engages all levels of staff in procedures and tools to safeguard quality deliverables for MTS:

### Tier 1: Document Control, Versioning, and Redundancy

**Full Staff Engagement:** All levels of staff engage in document control by utilizing EPIC's SharePoint, a Microsoft file management platform and collaboration tool. SharePoint automatically supports error-free versioning control, real-time collaboration, file organization, and modification change tracking. Each change to any project document is tracked and can be rolled back, if necessary. EPIC even employs dedicated IT staff that develop and maintain the SharePoint system.

**Document Availability and Retention:** All personnel working on the project have access to the SharePoint filing system, which is accessed only with a unique log-in username and password. SharePoint file storage allows for controlled access requirements, selective editing abilities, and document version tracking. SharePoint is stored on Microsoft's enterprise cloud platform which guarantees near 100% up-time and built-in redundancy. All records are maintained by EPIC for a statutorily required 7-year period.

## Tier 2: QA/QC Checklists & Peer Review

**QA/QC Compliance Checklists:** QA/QC compliance checklists ensure project documentation contains consistent and accurate information. QC/QC Checklists are utilized for distinct relocation milestones and deliverables. Checklists verify file details and documents issues/resolutions, and require approval signatures from the Preparer, Independent Reviewer, and the Project Manager. Completing this written form is an effective way of identifying concerns and issues that require review on the project.

**Peer Review of Project Documentation:** All documents prepared by EPIC will be reviewed by at least one other experienced agent and signed off by the Project Manager before submission to MTS. The application of EPIC’s dual quality reviews process is a key component in upholding EPIC’s reputation for high-quality deliverables. A final review of the document is conducted by the Project Manager prior to delivery. Each file will have a review checklist attached to the file prior to close out.

## Tier 3: Spot Check Files & Project Reporting

**Spot Checking:** Relocation files are randomly spot-checked at various milestones throughout the project to verify that all documents are uploaded and maintained into electronic and hard files. Project Managers or their designated staff can perform the spot check QA/QC. Diary logs are reviewed regularly to ensure that communications are being tracked on a “real time” basis.

**Reporting:** The EPIC Project Manager will review all project reports and electronic access to EPIC’s progress can be provided to MTS for real-time visibility into project progress.

## Budget and Schedule Controls

CRA has a track record of delivering high quality projects on-schedule and within budget. Our outstanding organizational skills and technical capabilities in combination with the strong support from our experienced and highly-qualified staff – including our seamless internal team communication developed over years of working together – will ensure successful project completion.

CRA uses an interactive web-based management system to assist our project and task managers to successfully maintain control of a project budget by providing real-time status reports on performance, variances, forecasts, and expenditures for all project tasks. We apply earned value management as the primary means of monitoring project progress and forecasting performance by integrating the three fundamental components of every task order — scope, schedule, and budget. This allows CRA to evaluate and control project risk by planning and monitoring project performance.

**Specifically from EPIC, the firm has several resources to ensure project schedule and budget are successfully maintained.** EPIC has well-established relationships with familiar vendors who understand EPIC’s standards of quality and expectation for budget-friendly efficient services. EPIC has experience successfully securing creative budget-friendly solutions to meet the specific needs of tenants. Monthly EPIC invoices contain the total budget, project-to-date actuals, and the remaining budget. While invoices are produced by EPIC’s Accounting Department, they are reviewed and approved by EPIC Project Managers as well. This reinforces the status of the project in budgetary terms for the entire EPIC team. If project scope changes, EPIC will communicate with CRA and MTS as soon as possible in order to have a conversation regarding the reduction or addition in budget. Additional cost controls include EPIC’s vertical management organization and mentorship program (which drastically reduces high hourly costs for executive involvement) and dedicated Project Accounting team assigned to this project to support EPIC technical leads.



# 3. Project Understanding and Approach

## Project Understanding

There are 17 non-residential businesses and three (3) personal property only relocations required for this WOA as part of the CTAC Real Estate Acquisition Tenant Relocation Services project. The business occupants are eligible to receive relocation assistance and advisory services in accordance with prevailing regulations. CR Associates (CRA) is contracted with San Diego Metropolitan Transit System (MTS) for this project and is enlisting qualified firm, Epic Land Solutions, Inc. (EPIC), to provide relocation assistance and advisory services for the displaced businesses. It is understood that three (3) of the four (4) parcel owners have been contacted and tenants are roughly understood for these parcels. The fourth parcel (APN 541-611-31-00) MTS has not been able to make contact and exact tenant arrangement are unknown. Currently, it is assumed that at least one (1) business requires relocation from that parcel. In addition, it is also assumed that relocation assistance is needed for APN 541-611-27-00 for the parking lot facility housed there. Conducting preliminary research, the EPIC team has further refined and added additional detail to MTS' Exhibit A provided in the RFP, as included in Exhibit B appended at the end of this proposal.



## Key Project Considerations

### #1 - Focus on Re-Establishing Businesses in the San Diego Community

**Solutions:** At the Notice to Proceed, it will be imperative for EPIC to quickly identify suitable replacement sites available in the market for each displaced business. Next, EPIC will advise each displaced business to plan their move, build-out replacement sites, obtain necessary health and safety permits, and other items to move and launch at a new location. EPIC will work closely with MTS and the local jurisdiction to pursue available replacement sites and obtain required permits.

**Prior Success:** This Project's Relocation Services Lead, Eddie Quintero, successfully relocated restaurants and other commercial business for the METRO 605 Hot Spots project on Beverly Blvd in Pico Rivera. Eddie was able to find a replacement site for Casa Jimenez Restaurant across the street! His efforts reduced Loss of Goodwill compensation and enabled Casa Jimenez Restaurant to continue serving delicious food to the Pico Rivera community to this day!



### #2 - Achieving Vacancy On-Time for Demolition & Construction

**Solutions:** EPIC will prepare all notifications for property owners and tenants. EPIC will work with tenants to help them thoroughly understand the project schedule and assist them to relocate as promptly as possible. Relocation schedules will be determined "in reverse" from the final estimated demolition/construction dates to allow ample time for businesses to secure replacement units and re-establish prior to demolition/construction. EPIC recommends as soon as a property is vacated, clearing and demolition should occur to minimize costs for property management. EPIC will work with MTS to determine the need dates for each business suite slated for demolition/clearance and perform relocation assistance and interim property management services, as needed to meet the construction objectives.

**Prior Success:** For the City of Palmdale Avenue R Complete Streets, EPIC performed interim property management tasks for acquired commercial sites including collecting lease and rent payments for newly City-acquired property

### #3 - Obtaining Conditional Use Permits for Applicable Businesses at their New Site

**Solutions:** A conditional use permit allows a city or county to consider special uses which may be essential or desirable to a particular community, but which are not allowed as a matter of right within a zoning district. As part of EPIC's Relocation Advisory services, agents will assist business owners with obtaining conditional use permits and any other local health and safety permits required to re-establish at their replacement site and ensure the business conforms to local jurisdictional rules.

**Prior Success:** Relocation Services Lead, Eddie Quintero, has extensive experience advising business owners in obtaining conditional use permits. For the METRO 605 Hot Spots program, Eddie consulted a liquor store obtain a CUP and licensing from the California Department of Alcoholic Beverage Control.



### #4 - Difficulties Identifying & Securing Replacement Sites Comparable to Current Reduced Rent

**Solutions:** As part of EPIC's Relocation Advisory services, the EPIC agent will work closely with business tenants and, where applicable, the business' contracted real estate agent, to negotiate and execute the new lease agreement for the replacement site. EPIC will make every effort to prevent financial hardship to the business tenant when securing and establishing the replacement site. EPIC will work closely with the business tenant to find a suitable solution that will assist the displaced business tenant with covering gaps in operating costs by considering loss of business goodwill and other business programs available by the City.

**Prior Success:** For every relocation project, EPIC agents review draft lease agreements on behalf of the business owner. This allows us appropriately support the tenants for their unique needs, such as reduced rental rates. The EPIC team has navigated this challenge successfully on the SBCTA West Valley Connector project, where the team was able to successfully relocate a majority of tenants to accommodate their business needs while accounting for the lower rents they had.

## #5 - Timely Reporting of Vacancies & Certificate of Abandonment for Property Management Services

**Solutions:** The EPIC Relocation Agent will work with the EPIC Property Management Lead to obtain keys for Property Management team to take over to secure and service property as needed. Immediately, EPIC Property Management Lead will secure the building or office suite, including but not limited to, change locks, fencing, board-up, etc., to mitigate tampering and unlawful occupants on the property. EPIC Property Management Lead will engage and notify the security vendor of property vacancies to maintain site safety and avoid unlawful entry.

**Prior Success:** On EPIC's RCTC Property Management On-Call contract, the EPIC team has been able to finalize Certificates of Abandonment to protect the owner agency from liability for the removal of any items left on the property, preventing any future litigation from the relocated tenants. Any large items left on the property are distinctly noted in Certificates of Abandonment signed by the tenant to ensure all parties are on the same page.



## #6 - Organized Subcontractor Agreements & Invoicing

**Solutions:** Several vendors may be required to fulfill property management needs which results in multiple invoices. All anticipated subconsultants for property management services will contract directly with EPIC for streamlined services. EPIC has a dedicated Project Accountant and corporate Contracts Managers—important corporate resources for the Project Managers to efficiently establish and administer master agreements, vendor work orders, insurance and licensing records, and accounts payable/receiving.

**Prior Success:** EPIC's internal systems allow for optimized organization and prompt noticing of invoicing for any subconsultants required to fulfill relocation or property management services.

## #7 - Safety Concerns for Vacant Land Once Buildings are Demolished and Before New Construction

**Solutions:** EPIC's Property Management Lead will be available to support MTS as needed to coordinate the establishment of 602 (Trespass Notices) with local law enforcement once buildings have been demolished to ensure that homeless encampments or trespassers can be appropriately handled and any items brought onto the vacant land can be properly disposed of once notice has been made to the trespassers.

**Prior Success:** EPIC has found that filing 602 forms with local law enforcement can greatly enhance an agency's power over their vacant property to ensure it remains vacant and they have appropriate law enforcement support.



## Scope Approach

A qualified team of relocation assistance professionals at EPIC shall complete the relocation assistance and advisory services in accordance with provisions established by the project's Relocation Plan and prevailing regulations defined by the Uniform Relocation Assistance and Real Property Acquisition Policies Act of 1970 as Amended, California Government Code Title 1, Chapter 16, Sections 7260-7277, Relocation Assistance Law and California Government Code Title 25, Division 1, Chapter 6, Sections 6000-6198, California Relocation Assistance and Real Property Acquisition Guidelines, and local laws where applicable.

EPIC takes pride in administering a relocation program that recognizes the delicate nature required when relocating a business tenant occupant or owner from their place of business. Our relocation assistance program strives to minimize hardship and ensure that all displaced tenants are treated equitably and obtain the relocation assistance they are entitled to under California state law. Being sensitive to the needs and concerns of the business occupant is not only beneficial to the Project, but also goes a long way toward alleviating the very human, sometimes traumatic, reaction faced by businesses who are displaced and need to move to a new location.

Throughout the project, **Relocation Task Manager, Eddie Quintero** and **Property Management Task Manager, Darcy Mendoza, SR/WA, R/W-NAC**, will provide regular communication, reporting, quality assurance and accounting oversight to ensure effective project delivery and adherence to schedule and budget. EPIC’s relocation assistance and property management services will follow a seven-step process for the commercial businesses and personal property impacted in this project:

- ▶ Prepare Draft Relocation Plan (Conduct Tenant Interviews)
- ▶ Draft FF&E Offer Letters (Establish Ownership of FF&E)
- ▶ Provide Notices and FF&E Offer to Tenant (GIN, Info. Brochure, Cert. of Lawful Presence, NOE, Informational 90 Day Notice to Vacate)
- ▶ Tenant Relocation Assistance (i.e. Advisory Services [Replacement Site Referrals], Securing Replacement Site, Processing Relocation Assistance Claim, Processing Tenant/Seller Agreement or Bill of Sale)
- ▶ Conduct Certificate of Abandonment
- ▶ Property Management (Execute Tenant Estoppels, Execute Lease Agreements (if applicable), Provide New Property Management Letter, Collect Rent)
- ▶ Relocation Assistance File Close Out



### Task 1.1 - Project Management

Task Order Manager, Aryo Rad with CRA, will provide comprehensive oversight for the duration of this WOA. EPIC will work closely with CRA and MTS to coordinate all relocation and property management services. EPIC will develop a project schedule and will adjust as necessary throughout the project. EPIC will maintain electronic files for the business occupant case, including a diary of communication with the business representative that captures salient discussion items, phone calls, emails, and other pertinent information. Tenant files also contain copies of all notices, claim forms, and any correspondence relevant to the relocation. EPIC will also keep a spreadsheet to track all the notices that have been sent, posted, and signed by each tenant. EPIC will maintain a Relocation Move Schedule spreadsheet to track when all the tenants will be moving.

### Task 2.1 - Relocation Plan

EPIC will prepare a Relocation Plan that considers all 17 non-residential business displacements and three (3) personal property only relocations involved on the project to analyze relocation options, anticipate all costs, outline the needs of residents, and outline plan for claim disbursements. The plan will verify the feasibility of anticipated relocations and forms an itemized project budget, including lodging, meal, transportation, and moving expenses. To prepare the Relocation Plan, EPIC will interview displaced occupants to understand challenges and better estimate relocation costs. The Relocation Plan will be prepared in accordance with state guidelines, rules, and regulations including URA and California Code of Regulations Title 25, § 6038. The Relocation Plan will be submitted to MTS for review and EPIC will perform edits as needed and memorialize the final approved version.



### Task 2.2 - Occupant Interviews & Notices

To initiate the relocation process, an assigned EPIC Relocation Agent will make direct contact with an authorized representative of the business and explain the relocation assistance program and eligibility requirements for relocation payments to the impacted business owner and/or tenant occupant. The agent will maintain a diary of relocation details and communications, capturing all salient conversations, discussions, emails, and other pertinent information with owners and representatives. During the interview, they will also request a copy of the lease agreement, as needed. EPIC will prepare the following notices and memos to be provided to the business owner and/or tenant:

- ▶ General Information Notice (GIN)
- ▶ Business Interview Form
- ▶ Informational Brochure
- ▶ Certificate of Lawful Presence
- ▶ Notice of Eligibility (NOE)—Non-Residential/Business Occupant
- ▶ 90-Day Notice to Vacate [required by federal law]
- ▶ 60/30-Day Notice to Vacate [as necessary, per MTS’ preference]



Relocation entitlements will be calculated in accordance with provisions of the California relocation legislation, Government Code Section 7260 et. Seq., Title 25 Chapter 6, Relocation Assistance and Real Property Acquisition Guidelines, and local rules and guidelines, as applicable.

### Task 2.3 - Present & Offer Fixtures and Equipment (F&E) Appraisal

EPIC will review the Fixtures and Equipment (F&E) appraisals (provided by MTS) and provide copies to the owner and tenant with all valuations redacted. EPIC will resolve any disagreement between owner and tenant claim of ownership, how an item is categorized, and compensation to be paid between owner and tenant. EPIC's agents will obtain notarized Statement of Ownership documents from both owner and tenant and will execute a bill of sale to the tenant.



### Task 2.4 - Relocation Assistance Advisory Services

All entities who may be eligible for relocation entitlements must have their rights fully explained as early as possible. As part of advisory assistance, it is important to establish a clear line of communication with the displaced business owner/tenant. EPIC will provide the following services during the Relocation Process:

- ▶ Thoroughly explain relocation entitlements to the tenants per California State Regulations
- ▶ Relocation Advisory Assistance (i.e., review lease agreements for replacement site, as needed)
- ▶ Secure move bids
- ▶ Process claims for displacees (Fixed Moving Payment Claim for occupants; Relocation Assistance Claim for tenant and/or owner occupant; deliver payments)
- ▶ Moving/Reestablishment/Searching or Fixed Payment In-Lieu of Actual Moving and Related Expense Claim for business occupant

### Task 2.5 - Final Close-Out and Documentation

EPIC will prepare the final documentation package for submittal to MTS to approve the relocation process has been completed in accordance with

prevailing regulations. Such package shall include but not be limited to: (i) all signed documents and original signatures of business occupant; (ii) diary of communication with tenant/owner; and (iii) other relevant relocation information.



### Task 3.1 - Interim Property Management

EPIC's property management specialists, led by **Property Management Lead, Darcy Mendoza**, have years of experience managing hundreds of business and residential properties for public agencies. For the CTAC project, EPIC property management services will include:

- ▶ Rent collection on leased property agreements and maintain trust account.
- ▶ Comprehensive tenant management, including lease management, new lease updates or agreements (as needed), tenant estoppals, Certificates of Insurance (COI), and a comprehensive tenant tracker for MTS' use. This tracker will allow MTS to see at a glance tenant lease status, insurance status, and other important information.
- ▶ Routine building maintenance/site inspections supported by well-established vendor relationships, including graffiti removal, vandalism remediation, plumbing, electrical, weed abatement, and general building infrastructure maintenance.
- ▶ Secure properties with fencing, board-ups, locks, and security of vacant buildings, as necessary. This includes contracting directly with a security vendor subconsultant as needed.
- ▶ Coordinate with pest control mitigation companies, as needed, for vector control.
- ▶ Establish utility billing close out and transfer to MTS following tenant vacancy.
- ▶ Provide immediate emergency response and law enforcement engagement (602 Trespass Notices).
- ▶ As needed, hazardous materials testing and abatement, and demolition and site clearance coordination.

# 4. Schedule

Between CRA and EPIC, our team has extensive local resources available to us for this project to ensure the project remains on schedule. These resources include regional offices based in San Diego, extensive internal resource professionals internally and available through EPIC’s CLS Family of Companies to tap for additional staffing resources as needed, and several established relationships with service vendors in both the relocation and property management space that can be incorporated as needed. We anticipate the relocation assistance services to be completed within 42 months from NTP. Upon further review of the RFP schedule, we have found areas to optimize and provide further clarity, as noted below:

Task	2024 Qtr 2	2024 Qtr 3	2024 Qtr 4	2025 Qtr 1	2025 Qtr 2	2025 Qtr 3	2025 Qtr 4	2026 Qtr 1	2026 Qtr 2	2026 Qtr 3	2026 Qtr 4	2027 Qtr 1	2027 Qtr 2	2027 Qtr 3	2027 Qtr 4
<b>Project Management</b>	[Red bar spanning all quarters]														
<b>Tenant Interviews</b>	[Red bar]														
<b>Relocation Plan</b>	[Red bar]														
<b>Prepare F&amp;E Offer Package and Present to Tenant</b>		[Red bar]	[Red bar]	[Red bar]	[Red bar]	[Red bar]	[Red bar]	[Red bar]	[Red bar]	[Red bar]	[Red bar]	[Red bar]	[Red bar]	[Red bar]	[Red bar]
<b>Relocation Assistance</b>		[Red bar]	[Red bar]	[Red bar]	[Red bar]	[Red bar]	[Red bar]	[Red bar]	[Red bar]	[Red bar]	[Red bar]	[Red bar]	[Red bar]	[Red bar]	[Red bar]
<b>Property Management</b>	[Red bar spanning all quarters]														
<b>Closeout</b>												[Red bar]	[Red bar]	[Red bar]	[Red bar]

**Tenant Interviews will occur promptly following NTP** to formulate the Relocation Plan.

**Draft Relocation Plan will be completed within 60 days** (this time includes MTS review period to make comments). **This is followed by another 60 days to allow public comments and board approval.** Tenants are allowed 30 days to review within that 60-day timeframe along with the rest of the public.

Depending on when the Relocation Plan is approved, **F&E offer packages and relocation assistance may be able to begin sooner**, potentially 2024 Qtr 4.

Tenants are **anticipated to vacate within 12-18 months** following their F&E Offer and other relevant notices and relocation assistance.

Summary of Task Timelines		
<p><b>Project Management:</b> May 2024 [Q2] - Nov 2027 [Q4] (Full Project Duration; 42 months)</p> <p><b>Tenant Interviews:</b> May 2024 [Q2] - Jun 2024 [Q2] (NTP + 1 month)</p> <p><b>Relocation Plan:</b> May 2024 [Q2] - August 2024 [Q3] (NTP + 4 months)</p>	<p><b>Prepare F&amp;E Offer Package and Present to Tenant:</b> September 2024 [Q3] - Feb 2027 [Q1] (Relocation Plan Approval + 30 months)</p> <p><b>Relocation Assistance:</b> September 2024 [Q3] - Feb 2027 [Q1] (Relocation Plan Approval + 30 months)</p>	<p><b>Property Management:</b> May 2024 [Q2] - Nov 2027 [Q4] (Full Project Duration, as needed; 42 months)</p> <p><b>Closeout:</b> Nov 2026 [Q4] - Nov 2027 [Q4] (Month 30 - Month 42)</p>

## 5. DBE Subcontractor Utilization Plan

Chen Ryan Associates, Inc. (DBA CR Associates) is a recognized Disadvantaged Business Enterprise (DBE) with CUCP Public Directory Certification Number 40083. Therefore, while Epic Land Solutions, Inc. is not a DBE Subcontractor, any DBE goals are satisfactorily met with at least 10% participation from CRA to provide Project Management services for the duration of this task order.

## 6. Exceptions/Deviations to RFP

Due to the schedule duration of this project spanning over multiple years, CR Associates and Epic Land Solutions, Inc. respectfully request the following adjustment to the RFP language, Section XI – Pricing, removing it in its entirety and replacing it with the language below:

*Per Section B – Allowable Escalation of the On-Call Architect & Engineering Master Agreement with San Diego Metropolitan Transit Systems (MTS), escalations are allowed pursuant to the Employment Cost Index (ECI) for the given year. Therefore, staff billing rate escalations will be allowed on an annual basis and are to be submitted no later than December 15th of each year. Once approved by MTS, these escalated rates will be available for use January 1st of each year of the Agreement, unless otherwise Amended by the Parties. Despite the rate escalation, the not-to-exceed fee for professional services shall remain firm for the duration of this task order.*

DRAFT

Exhibit A  
Resumes



## Ross Duenas PE

Contract Manager

Ross has 18 years of experience designing and managing transportation and public works projects for public agencies. He has managed multi-disciplinary projects involving multimodal Complete Streets, traffic control, traffic calming, and large outdoor pedestrian spaces. Ross' responsibilities have included managing traffic-related improvement projects, designing, and preparing traffic control plans, as well as signing and striping plans, roadway design, site design, stormwater analysis and design, wet utility design, and water quality.

Over the last decade, Ross has designed tens of millions of dollars of construction documents throughout San Diego County. This experience equips him to bring unique insights into the constraints and opportunities required for the appropriate use of local and regional engineering standards. He has also been part of the management team for 10+ similar and innovative roadway projects that he helped take through final design.

### EXPERIENCE

18 years

### EDUCATION

BS, Civil Engineering,  
 Florida State University

### ACCREDITATIONS

Professional Engineer,  
 California #84324

### AFFILIATIONS

American Public Works  
 Association (APWA),  
 Member

### RELEVANT PROJECT EXPERIENCE

**Downtown Cycle Track Network Wayfinding and Cortez Hill Pedestrian Wayfinding, Civic Center, San Diego, CA: Project Manager** – Ross is responsible for the final design of wayfinding signage to support the three phases of the City of San Diego's downtown cycle track network. The improvement will enhance the public realm within the Downtown San Diego by complementing the downtown pedestrian wayfinding signage and by facilitating a safe environment for multi-modal transportation. Similarly, Ross oversees the wayfinding signage and gateway design for the Cortez Hill downtown neighborhood. The wayfinding systems will identify key destinations and public amenities, making places easy to travel by foot or bicycle. The signs will communicate clear and concise functional wayfinding information, helping to improve circulation and linking residents and tourists to community areas, shopping opportunities, and public transportation.

**South Bay Rapid – Otay Mesa Transit Center – Final Design, SANDAG, San Diego, CA: Project Manager** – who worked closely with SANDAG, MTS and Caltrans to provide final design services for the Otay Mesa ITC, the southern terminus of the South Bay Rapid service. Design included drainage and water quality, landscape, urban design, communication, and retaining walls. Ross assisted SANDAG in the right-of-way acquisition process, which included the decertification of a 1.7-acre Excess Parcel from Caltrans. A PEER and Encroachment Permit were required by Caltrans for improvements to the SR 905/Siempre Viva Road interchange.

**Downtown Rapid Stations, Final Design PS&E, SANDAG, San Diego, CA: Project Manager** – who led the design services during construction efforts for the final PS&E for the Downtown Rapid Stations project, which included attending weekly meetings, submittal review, and responding to requests for information. The project includes three Rapid Bus Stations on Broadway and the terminal station at America Plaza. Ross led coordination and design efforts between multiple disciplines including communications for the stations, urban design, civil design, custom bus shelters, kiosks, extensive utility coordination, and stage construction.



# Aryo Rad PE

Task Order Manager

Aryo Rad brings more than two decades of civil engineering experience in the areas of planning, permitting, designing, bidding, and constructing transportation, traffic, and transit projects in Southern California. He has a successful track record of leading complex multidisciplinary transportation and transit projects.

He has worked with engineering and planning departments for more than 50 regional transit and transportation agencies, assisting with transportation and transit projects. Aryo's role as project manager for several local projects provide him with unique understanding of the MTS needs, potential challenges, and design constraints.

## EXPERIENCE

25 years

## EDUCATION

MS, Civil Engineering,  
 California State  
 University

MS, Systems  
 Engineering, Industrial  
 Management Institute

## ACCREDITATIONS

Professional Engineer,  
 California #C81231

## AFFILIATIONS

American Public Works  
 Association (APWA),  
 Southern California  
 Chapter

American Society of  
 Civil Engineers

American Public Works  
 Association

American Association  
 of State

Highway and  
 Transportation  
 Officials

## RELEVANT PROJECT EXPERIENCE

**University Bikeway, SANDAG, San Diego, CA:** – QA/QC manager for this 2.9-mile urban bikeway that runs through the mid-city and eastern neighborhoods of San Diego, ultimately connecting to the city of La Mesa at its eastern terminus. Proposed improvements include protected bikeways (Class IV).

**Main Street Green Street – Phase 1 Improvements, City of El Cajon, El Cajon, CA:** – QA/QC manager for the revitalization of the Main Street corridor, which will become an attractive multimodal gateway. CR Associates (CRA) is finalizing the design to implement a road diet and vehicle lane narrowing in order to install enhanced sidewalks and access ramps, Class IV separated bikeways, enhanced pedestrian crossings, LID planters, signage, thematic site furnishings, and safety lighting.

**Jamacha Road Improvements (HSIP), City of El Cajon, El Cajon, CA:** – Technical advisor for this proposed project, which is part of Caltrans Highway Safety Improvement Program (HSIP) Cycle 9. Proposed improvements include median nose modification, high visibility crosswalks, curb extensions, center raised medians, ADA improvements, traffic signal modifications, RRFB crossings, bulb-outs, and bike lane improvements.

**MLK/Gage and Redondo Beach Corridors – MAT Projects, LA Metro, Los Angeles and Redondo Beach, CA:** – Task lead/manager for Redondo Beach corridor for this project. CRA is leading the PA/ED phase and outreach engagement for the MLK/Gage and Redondo Beach corridors in partnership with Arellano Associates and LADOT. The project will implement LADOT's Dignity-Infused Community Engagement (DICE) approach and apply the community first engagement model. As part of this project, CBOs will help lead in the surrounding community about challenges walking and bicycling, ask residents and business owners, and other stakeholders to consider different design options/alternatives, and help the community narrow to a preferred alternative by reviewing trade off and benefits.



## EDDIE QUINTERO RELOCATION TASK MANAGER

Eddie is a Senior Relocation Project Manager who has built the last decade of his career managing and performing relocation assistance services on behalf of major public agencies throughout Southern California, including Los Angeles County Metropolitan Transportation Authority, Orange County Transportation Authority, and various municipalities. He is a talented team leader, organized project manager, and committed custodian of prevailing regulations as defined by the Uniform Act and State of California. Eddie has a formal education in Urban and Environmental Planning and served as an Associate Planner for the City of Taft in Kern County. More recently, Eddie managed several complex relocation cases for commercial and industrial uses displaced by the Metro D Line and Gerald Desmond Bridge Replacement. He has completed over 500 temporary and permanent residential relocations throughout his career. As Relocation Task Manager for the MTS CTAC project, Eddie will be responsible for comprehensive oversight of the relocation process, including Relocation Plan, tenant interviews, F&E appraisal offers, relocation assistance, and file close-out documentation.



**EPIC LAND SOLUTIONS, INC.**

### YEARS OF EXPERIENCE

12 (2 with EPIC)



### LICENSURE

California Real Estate Salesperson  
 #01950486



### ASSOCIATIONS

Member, International Right of Way  
 Association, #7913952



### EDUCATION

B.S., Environmental Resource  
 Management with concentration in Land  
 Use and Planning, California State  
 University, Bakersfield



### LANGUAGE SKILLS

Bilingual (English/Spanish Fluency)

### NOTABLE PROJECTS

**Inglewood Transit Connector (ITC), City of Inglewood, CA:** The ITC is a 1.6-mile (2.6 km) fully elevated, automated guideway transit system proposed in Inglewood, California that will connect the Downtown Inglewood station on the K Line of the Los Angeles Metro Rail system to nearby major sports and entertainment venues. To kick off the project, EPIC assisted the City to draft and complete the Real Estate Acquisition Management Plan (RAMP) and Draft Relocation Plan for the project, both approved by the Federal Transit Administration (FTA) after EPIC addressed comments. As Relocation Project Manager, Eddie was responsible for the entire RAMP and Relocation Plan for the project, providing comprehensive oversight to EPIC's team for the ongoing pre-acquisition planning tasks including Relocation Claim Forms and review of various policy and procedures.

**Parking Lease Agreement for Costa Mesa Freeway (State Route 55) Improvement Project, from Interstate 405 to Interstate 5, Orange County Transportation Authority (OCTA), Santa Ana, CA:** In one segment of this project, the proposed alignment was severely impacting parking and threatening the relocation of industrial businesses. To avoid costly business relocations, OCTA enlisted EPIC as its sole source right of way consultant to acquire rights to parking from an adjacent property owner with excess parking spaces not impacted by the freeway improvement project. Eddie helped OCTA save millions of dollars by successfully negotiating new lease agreements to acquire the parking rights for the impacted businesses, avoiding business relocations.

**West Valley Connector Bus Rapid Transit (BRT) Corridor, San Bernardino County Transportation Authority (SBCTA), Montclair and Ontario, CA:** Due to the dedicated bus lane design in this project section, 10 of the 56 parcels will be acquired as full takes and resulting in 25 relocation assistance cases (consisting of 17 businesses and 8 residential displacements). Eddie is performing relocation planning services and providing training and advising for relocation agents who will be interviewing up to 25 displaced residential and non-residential tenants. For the business relocations, Eddie acquired and performed quality reviews of the fixtures and equipment appraisals.

*"We have had a great experience working with Eddie and EPIC. They are responsive and flexible – even with last minute requests (5/5 Client Satisfaction Score)  
 - Tami McCrossen-Orr,  
 Trifiletti Consulting for  
 the City of Inglewood*



## DARCY MENDOZA, SR/WA, R/W-NAC PROPERTY MANAGEMENT TASK MANAGER



EPIC LAND SOLUTIONS, INC.

### YEARS OF EXPERIENCE

20 (11 with EPIC)



### LICENSURE

Real Estate Salesperson, CA #02004708

Notary Public, CA Commission  
#2330562



### CERTIFICATIONS

Senior Right of Way Professional  
(SR/WA), International Right of Way  
Association (IRWA)

Right of Way Negotiation/Acquisition  
Specialist Certification (R/W-NAC),  
IRWA



### EDUCATION

General Studies, Saddleback College,  
Mission Viejo & Mt. San Jacinto College

Darcy is an Assistant Regional Manager that has been involved in all aspects of right of way project management, including quality assurance and oversight for property management and relocation services. Prior to EPIC, she was a Title & Escrow Officer for a diverse range of customers throughout Southern California and has a strong understanding of complexities related to real property transacting. Darcy has provided long-term and interim property management services for over 500 properties acquired by RCTC and SBCTA over the past few years, coordinating a wide variety of tasks including collection of rent, lease and license management, and routine inspections. As Property Management Task Manager for the MTS CTAC project, Darcy will oversee all property management tasks including rent collection, lease management, site security, property maintenance, and proactive problem solving for any property management challenges that may arise.

### NOTABLE EXPERIENCE

**Property Management Services On-Call Contract, Riverside County Transportation Commission (RCTC), Riverside County, CA:** As the Senior Property Manager for RCTC, Darcy oversees the staff that reviews and upgrades licenses and leases on RCTC property, developed a property management and tenant contract database for the agency, and reviews/resolves title and boundary issues on an ongoing basis. Darcy has even drafted RCTC's official policies and procedures for property management and other real estate matters. Her work requires coordination with BNSF, Metrolink, and the planning departments, police, and code enforcement authorities from multiple local municipalities.

**West Valley Connector Bus Rapid Transit (BRT) Corridor, San Bernardino County Transportation Authority (SBCTA), Montclair and Ontario, CA:** The EPIC team previously performed title and escrow coordination, offer package preparation, and right of way acquisition services for 56 property impacts in this BRT development project. As parcels are acquired, tenants relocated, and buildings are vacated, Darcy is overseeing the team performing interim property maintenance and management tasks, including coordination of hazardous materials testing, abatement, and demolition coordination to clear project sites and prepare the parcels for construction. Tasks involve asbestos testing and abatement, contractor requests for bids, bid selection, contractor performance oversight, fencing/board-up, and utility shut-off for gas, water, electric. The EPIC team also coordinated with the City of Ontario to expedite approvals of environmental and contractor permits required for these tasks.

**Mount Vernon Avenue Viaduct over BNSF Intermodal Yard Replacement Program/Construction Management (PCM), SBCTA, San Bernardino, CA:** The Mount Vernon Viaduct over BNSF Intermodal Yard Replacement is a \$230 million Design-Build project involving the demolition of the existing viaduct over the BNSF Intermodal Yard in the City of San Bernardino and construction of a new bridge over 1,000' in length. To construct the bridge, over 40 tax parcels were acquired, 40+ residences relocated, and the structures demolished. Darcy and the EPIC team provided interim property management for the land acquired and cleared. Task management included coordination with Joshua Grading to install security fencing and board-ups ahead of demolition, while also coordinating with law enforcement to manage trespassers and homeless encampments.

*"It has been a pleasure to work with Darcy on several projects, including an interchange, quiet title, property management and excess land sales."*

*- Mark Lancaster, Co. of Riverside Transportation & Land Management Agency (TLMA)*





## ADDIEL FLORES, RWA, BROKER SENIOR RELOCATION AGENT

Addiel is a relocation professional with over 10 years of experience transacting real estate and performing relocation assistance on behalf of public agencies throughout Southern California. He has extensive experience locating suitable replacement business sites and housing throughout multiple states for displaced tenants - performing 500+ temporary and permanent relocations in the span of his career. Addiel has supported some of EPIC's largest relocation projects, including the Inglewood Transit Connector, granting him a wealth of understanding for relocation assistance procedures and requirements. Addiel is a veteran of the United States Army, having served from August 2000 through February 2012. As a Senior Relocation Agent for the MTS CTAC project, Addiel will provide direct boots-on-the-ground relocation assistance services including tenant interviews and notices, presentation of F&E appraisals, relocation assistance communications with tenants, and additional support as needed.



**EPIC LAND SOLUTIONS, INC.**

### YEARS OF EXPERIENCE

10 (1+ with EPIC)



### LICENSURE

California Real Estate Broker #01944802



### CERTIFICATIONS

Certified Right of Way Agent (RWA),  
International Right of Way Association  
(IRWA)



### EDUCATION

BS, Business Administration/Real Estate,  
California State Polytechnic University,  
Pomona



### IRWA COURSEWORK

Non-Residential Relocation Assistance  
Real Estate Negotiations  
Principal of Real Estate Appraisals  
Alternative Dispute Resolution  
Principals of Land Acquisition



### LANGUAGE SKILLS

Bilingual (English/Spanish Fluency)

### NOTABLE EXPERIENCE

**Downtown Bus Stopover, San Diego Association of Governments (SANDAG), San Diego, CA:** SANDAG sought to complete acquisitions for a block they already partially owned between State Street, Union Street, A Street, and B Street to construct a multiuse and bus stopover facility in Downtown San Diego. The proposed facility will provide an off-street location where transit vehicles can be parked for short periods between runs. In addition to the stopover, the facility has the potential to provide future office space for SANDAG and other tenants as part of a Transit Oriented Development (TOD) including office, retail, and housing, including affordable housing. A maximum of two full-takes were identified, with a maximum of six (6) non-residential relocations. EPIC is responsible for all relocation services on the project, including relocation plan, tenant interviews and notices, relocation assistance services, and final close-out documentation (including Certificate of Abandonment). As Relocation Project Manager, Addiel is providing oversight and hands-on support for completion of tenant interviews, relocation plan, and relocation assistance.

**Interstate 5 and Oso Parkway (SR-73) Interchange Improvements, Orange County Transportation Authority (OCTA), Mission Viejo, CA:** This project improves traffic flow and safety through one of the most congested interchanges along the I-5 freeway in South Orange County. The project adds a southbound auxiliary lane in advance of the southbound off-ramp at Oso Parkway, widens the southbound off-ramp to Oso Parkway from one to two lanes, and widens the ramp lanes from three to four lanes. EPIC is the sole-source right of way consultant to OCTA finishing the right of tasks for this project. Addiel supported the delivery of the relocation assistance program to assist three (3) non-residential tenants that were displaced.

**Eastside School Relocation Services, Riverside Unified School District (RUSD), Riverside, CA:** Riverside Unified School District (RUSD) has a need to acquire certain properties in Riverside, CA such that the assemblage of those properties will allow for the development of a new Eastside elementary school. RUSD enlisted EPIC as its sole Relocation Assistance provider to coordinate relocation services for eight (8) remaining properties to complete the project. These properties include both commercially and residentially zoned properties. As Relocation Project Manager, Addiel has led the EPIC team in completion of tenant interviews and initial notices. Addiel and the EPIC team will provide comprehensive relocation assistance and offer notices once acquisition is complete.



## MARIA SAUZA, BROKER SENIOR RELOCATION AGENT

Maria is a seasoned real estate broker and relocation assistance agent with 20+ years of experience who has excelled as a successful negotiator, treating all stakeholders with respect and ensuring that all paperwork is completed on-time and properly filed. She has worked with a variety of clients throughout Southern California including transportation agencies, municipalities, housing authorities, school districts, and public utility companies. Maria has completed over 550 relocations throughout her career. Her compassion and thorough approach to relocation lends itself to EPIC's successful track record of relocation assistance services. As a Senior Relocation Agent for the MTS CTAC project, Maria will support relocation assistance services through thorough documentation maintenance, tenant interview and notice support, and additional support, as needed.



**EPIC LAND SOLUTIONS, INC.**

### YEARS OF EXPERIENCE

20 (6 with EPIC)



### LICENSURE

Real Estate Broker, CA #01238022

Notary Public, CA  
 Commission #2392145



### EDUCATION

International Right of Way Association  
 (IRWA) Coursework



### LANGUAGE SKILLS

Bilingual (English/Spanish Fluency)

### NOTABLE EXPERIENCE

**Costa Mesa Freeway (State Route 55) Improvement Project, from Interstate 405 to Interstate 5, Orange County Transportation Authority (OCTA), Santa Ana, Irvine and Tustin, CA:** This project adds one general purpose lane, one carpool lane and auxiliary lanes in each direction of this stretch of the freeway to reduce congestion and increase capacity. EPIC is the sole-source right of way consultant to OCTA finishing the right of tasks for 20 acquisition files, up to six relocation cases, and several utility relocations. As a Senior Relocation Agent on this project, Maria is performing relocation assistance advisory services for several non-residential tenants, including industrial business tenants (a shower door manufacturer and a deep cleaning operation) and a general contracting business.

**West Valley Connector Bus Rapid Transit (BRT) Corridor, San Bernardino County Transportation Authority (SBCTA), Pomona, Montclair, and Ontario, CA:** As Senior Relocation Agent, Maria is supporting the EPIC team with relocation planning services and relocation advisory services for 25 non-residential and residential tenant displacements in this project, as well as as-needed property rights acquisition support. This project is funded through the Federal Transit Administration (FTA) and Maria is maintaining documentation for the relocation program in compliance with FTA guidelines.

**Hillcrest Apartments Temporary Relocations, San Diego Housing Commission (SDHC), San Diego, CA:** In late 2020, SDHC acquired Hillcrest Apartments with 47 Single-Room Occupancy (SRO) units with 45 of those being affordable rental housing units and the two remaining for on-site property management. It was determined that renovations of the property, especially the balconies on several units, needed to be brought up to code. As Project Manager for the temporary relocations, Maria coordinated with 24 residents to arrange hotel accommodation during the renovations. She worked with handicapped residents and those with pets to get the right accommodation for everyone's needs. Throughout the entire project, Maria maintained sensitivity to needs and took extra effort to help those who were resistant to relocation feel more comfortable, resulting in positive feedback from numerous residents following the completion of their relocations. Relocation progress was documented thoroughly in SDHC's preferred excel spreadsheets. Maria excelled at providing residents with a home away from home during their renovations.



## YASMEEN FLORES RELOCATION AGENT

Yasmeen is a highly organized and driven Relocation Agent with 4+ years of experience who excels at problem solving, concise communication, and team collaboration for efficient production of client deliverables. She relies on her technical abilities to provide analysis and research on right of way utilizing GIS and Archibus to complete her research. Yasmeen uses her strong communication skills to provide translation services and create solutions to overcome language barriers in her negotiations. She excels at leading and supporting teams to ensure the scope of work is accurately carried out. Yasmeen has successfully completed over 175 relocations in her career. As a Relocation Agent for the MTS CTAC project, Yasmeen will provide direct boots-on-the-ground relocation assistance services including tenant interviews and notices, presentation of F&E appraisals, relocation assistance communications with tenants, and additional support, as needed.



EPIC LAND SOLUTIONS, INC.

### YEARS OF EXPERIENCE

4 (1 year at EPIC)



### EDUCATION

B.A., Public Policy and Administration,  
California State University, Long Beach

Residential Relocation Assistance  
coursework, International Right of Way  
Association (IRWA)



### LICENSURE

California Real Estate Salesperson  
#02199646



### ACCOMPLISHMENTS

Medal of Distinction, Crafton Hills  
College

Recognition of Outgoing Student  
Trustees, San Bernardino Community  
College District Board of Trustees



### PROFICIENCY

Microsoft Office 365  
Database maintenance  
GIS software  
Archibus



### LANGUAGE SKILLS

Bilingual (English/Spanish Fluency)

### NOTABLE PROJECTS

**Downtown Bus Stopover, San Diego Association of Governments (SANDAG), San Diego, CA:** SANDAG sought to complete acquisitions for a block they already partially owned between State Street, Union Street, A Street, and B Street to construct a multiuse and bus stopover facility in Downtown San Diego. The proposed facility will provide an off-street location where transit vehicles can be parked for short periods between runs. In addition to the stopover, the facility has the potential to provide future office space for SANDAG and other tenants as part of a Transit Oriented Development (TOD) including office, retail, and housing, including affordable housing. A maximum of two full-takes were identified, with a maximum of six (6) non-residential relocations. EPIC is responsible for all relocation services on the project, including relocation plan, tenant interviews and notices, relocation assistance services, and final close-out documentation (including Certificate of Abandonment). As Relocation Agent, Yasmeen is providing hands-on support for completion of tenant interviews, relocation plan, and relocation assistance services.

**Inglewood Transit Connector (ITC) Project, City of Inglewood, CA:** The Inglewood Transit Connector Project is a 1.6-mile (2.6 km) fully elevated, automated guideway transit system proposed in Inglewood, California that will connect the Downtown Inglewood station on the K Line of the Los Angeles Metro Rail system to the major sports and entertainment venues. As part of ongoing pre-acquisition planning tasks for the ITC project, Yasmeen is assisting the EPIC Right of Way Team with responses to FTA comments on Relocation Plan and is preparing Relocation Claim Forms and reviewing and providing comments to the Appraisal Policy and Procedures, Acquisition Policies and Procedures, and Relocation Policies and Procedures for the project.

**West Valley Connector Bus Rapid Transit (BRT) Corridor, San Bernardino County Transportation Authority (SBCTA), Ontario, CA:** Due to the dedicated bus lane design in Segment 4 of this project, 10 of the 56 parcels will be acquired as full takes and resulting in 25 relocation assistance cases (consisting of 17 businesses and 8 residential displacements). Property types included commercial retail suits, motels, restaurant franchises with vehicle drive-thru access, gas stations, and auto repair and auto dealers. As Relocation Agent, Yasmeen is supporting the delivery of Relocation Assistance services through in-depth documentation and coordination with the impacted businesses and residents.



## CHRISTINE WASFI RELOCATION AGENT

Christine Wasfi is a Relocation Agent with 10+ years of experience who is a talented negotiator, working professionally and patiently with property owners from various backgrounds to resolve conflicts, questions, and reach voluntary settlements. Due to her background in real estate, Christine easily navigates real estate market research, transaction details, and has a strong command of documentation best practices. Her growing portfolio of experience includes relocation services for a myriad of clients, including supporting EPIC's Inglewood Transit Connector and West Valley Connector projects. As a Relocation Agent for the MTS CTAC project, Christine will support relocation assistance services through thorough documentation maintenance, tenant interview and notice support, and additional support, as needed.



**EPIC LAND SOLUTIONS, INC.**

### YEARS OF EXPERIENCE

10 (1 with EPIC)



### LICENSURE

Real Estate Salesperson, CA #01936746



### EDUCATION

B.A., Business Administration, California State Polytechnic University, Pomona



### ASSOCIATIONS

Member, National association of Realtors

Member, Orange County Association of Realtors

### NOTABLE EXPERIENCE

**Inglewood Transit Connector (ITC) Project, City of Inglewood, CA:** The Inglewood Transit Connector Project is a 1.6-mile (2.6 km) fully elevated, automated guideway transit system proposed in Inglewood, California that will connect the Downtown Inglewood station on the K Line of the Los Angeles Metro Rail system to the major sports and entertainment venues. Christine is providing preliminary support for anticipated relocation assistance tasks as the Relocation Plan has been recently finalized.

**West Valley Connector Bus Rapid Transit (BRT) Corridor, San Bernardino County Transportation Authority (SBCTA), Montclair and Ontario, CA:** Due to the dedicated bus lane design in this section, 10 of the 56 parcels will be acquired as full takes and resulting in 25 relocation assistance cases (consisting of 17 businesses and 8 residential displacements). Christine is supporting the relocation team with supporting relocation assistance service noticing and tenant/resident communications.

**Eastside School Relocation Services, Riverside Unified School District (RUSD), Riverside, CA:** RUSD has a need to acquire certain properties in Riverside such that the assemblage of those properties will allow for the development of a new Eastside elementary school. RUSD enlisted EPIC as its sole Relocation Assistance provided to coordinate relocation services for eight (8) remaining properties to complete the project. These properties include both commercially and residentially zoned properties such as retail stores and a manufacturing facility. As Relocation Agent, Christine supported the completion of tenant interviews and initial notices. Christine and the EPIC team will provide comprehensive relocation assistance and offer notices once acquisition is complete.

**Replacement of the San Juan Creek Rail Bridge (LOSSAN Corridor), Orange County Transportation Authority (OCTA), San Juan Capistrano, CA:** As the sole-source Right of Way Consultant to OCTA, EPIC is supporting the acquisition of three (3) partial property acquisitions and one (1) personal property relocation for OCTA to construct the bridge replacement. Christine is supporting the maintenance of consistent documentation for the personal property relocation and acquisitions.



## VIVIAN LANZAORELLANA

### LEASE MANAGEMENT COORDINATOR

Vivian is an exemplary administrative professional with over 9 years of experience in supporting management and operation teams within demanding work environments. She is a driven team player who is highly detailed in her work and dedicated to deadlines. Vivian has provided extensive document maintenance on some of EPIC's largest property management contracts and beyond, overseeing hundreds of documents regularly and consistently. She is a veteran of the United States Navy, where she served for over five years as an Aviation Electronics Technician Level E-5 and received numerous honors. As Lease Management Coordinator, Vivian will support property management efforts with direct oversight of all tenant leases/insurance, coordination of new leases/insurance, data entry, and efficient file management.



EPIC LAND SOLUTIONS, INC.

#### YEARS OF EXPERIENCE

9 (1 year at EPIC)



#### LICENSURE

Notary Public, CA Commission  
#2438792



#### KEY SKILL SETS

Microsoft Office Suite – *Intermediate*

Adobe Acrobat Pro DC – *Intermediate*

CRM Software

Document Management

Type 58 WPM

Scheduling/Meeting Coordination



#### EDUCATION & PROFESSIONAL DEVELOPMENT

California Department of Insurance  
(CDI) Producer License, Accident Health  
& Life Agent, 2019

AT&T Corporate Online Courses  
Proprietary Vocational Certification  
AT&T 2020 Transformation Series: Big  
Data, Cloud Technology, 2016

AT&T Career Training Courses  
Environmental Health & Safety EH&S  
Trainer – Certification CPR & First Aid  
Certification Defensive Safety Driving

Naval Air Technical Training Center  
United States Navy Aviation Electronics

#### NOTABLE EXPERIENCE

**Property Management Services On-Call Contract, Riverside County Transportation Commission (RCTC), Riverside County, CA:** Vivian is currently performing document administrative duties for the RCTC Property Management contract. Her tasks include compiling documentation pertaining to the management of license agreements and file management and documentation back-up (including scanning hard files to create and file electronic copies). As the administrator working on behalf of RCTC, Vivian regularly engages with stakeholder agencies, such as the County of Riverside, Caltrans District 8 and SCRRA to coordinate the signing of documents and recording deeds. She has assisted EPIC's Contract Manager/Property Manager, Darcy Mendoza, with clearing up title deficiencies with the County Assessor.

**West Valley Connector Bus Rapid Transit (BRT) Corridor, San Bernardino County Transportation Authority (SBCTA), Pomona, Montclair, and Ontario, CA:** EPIC is performing appraisals, acquisitions, and relocations for Segment 4 of this project, which impacts 56 larger parcel groupings possessed by 53 unique property owners. Vivian supported the right of way agent team to compile, review, and mail Offer Packages and Relocation Notices to property owners for the acquisition and relocation of property in conflict with the project improvements. She continues to support EPIC's property management team with maintenance of tenant leases, insurance, and spreadsheets tracking that information and more, as needed.

**Plans, Specifications & Estimates (PS&E) for Ojai Ave (SR 150) and Maricopa Hwy (SR 33) Active Transportation Program (ATP) Complete Streets, City of Ojai, CA:** As a subconsultant to the engineer and in coordination with the City of Ojai, Vivian supported the EPIC right of way agent team to compile, review, and mail Offer Packages to property owners for the acquisition of property rights. Vivian ensured consistency and quality review of the Offer Packages so that they included all required informational brochures, Offer of Just Compensation letter, and related project information. Due to federal Active Transportation Program (ATP) funding, Vivian and the EPIC team ensured documentation was meticulously managed to ultimately obtain Caltrans Right of Way Certification for the project.

Exhibit B  
Refined  
Impact Table

Assessor's Tax Parcel Number (APN)	Parcel Address	Assessor Lot Acreage	Land Use	Business Address	Tenants	Business Type
541-611-31-00	4550 Federal Blvd	1.3773	Industrial	4550 Federal Blvd	Distribution International	Commercial and Industrial Insulation <i>(Assumed 1 tenant relocation due to no contact)</i>
541-611-04-00	4506-4520 Federal Blvd	5.4325	Industrial	4506 Federal Blvd	All Pro Stickers	Car Wraps, Building Advertisement
				4506 #A Federal Blvd	Brooke Paper Scissors	Luxury Home Staging
				4506 #B Federal Blvd	H&H Diversified Investment Co. Inc	Owner's Office
				4506 #D Federal Blvd	Drop Kick Brew	Coffee Distributor/Wholesaler
				4510 Federal Blvd	San Diego Scale	Mechanical Scale Distributor (Commercial & Industrial)
				4514 Federal Blvd	Cal Auctions	Auction House
				4514 #D Federal Blvd	Sanwood Fine Carpentry & Construction, Inc.	General Contractor, Remodels, and Renovations
				4514 #D Federal Blvd	L Electric	Electrician <i>(sub to Sandalwood)</i>
				4520 #A Federal Blvd	Half Off Wholesale	Wholesaler
				4520 #B Federal Blvd	Accessories Plus Fabrication	Welder & Metal Fabricator
541-611-34-00	4570-4586 Federal Blvd	2.6058	Commercial	4520 #C Federal Blvd	Pro-Active Concrete	Concrete Services (New Construction & Repairs)
				4576 Federal Blvd	Mixed Media Art Gallery and Studio	Art Studio
				4582 & 4584 Federal Blvd	Antonio's Metal Works, Inc.	Metal Fabricator
				4582 Federal Blvd	Iron Welding International	Welder <i>(sub to Antonio's)</i>
				4582 Federal Blvd	One Stop Metal Fabrication	Metal Fabricator <i>(sub to Antonio's)</i>
				4582 Federal Blvd #A	Robb's Security Bars and Fencing	<i>Unable to confirm at this time</i>
				4586 Federal Blvd	Vacant Building and Lot	N/A
4567 Federal Blvd	Action Gypsum Supply	Personal Property Storage of Misc				
541-611-27-00	Federal Blvd	2.3311	Commercial	N/A	Parking Lot	Parking <i>(Assumed 1 tenant relocation)</i>



**SAN DIEGO**

3900 5th Avenue, Suite 310  
San Diego, CA 92103

**LOS ANGELES**

714 W Olympic Boulevard, Suite 609  
Los Angeles, CA 90015



**ATTACHMENT B  
NEGOTIATED FEE PROPOSAL**

DRAFT

# Work Order Estimate Summary

**MTS Doc. No.**   
**Work Order No.** WOAXXX-AE-39  
**Attachment:** B

**Work Order Title:** 
**CLEAN TRANSIT ADVANCEMENT CAMPUS (CTAC)  
TENANT RELOCATION SERVICES**

**Project No:**

**Table 1 - Cost Codes Summary (Costs & Hours)**

Item	Cost Codes	Cost Codes Description	Total Costs
1		Labor - Epic Land Solutions	\$299,029.06
2		Expenses - Epic Land Solutions	\$204,335.00
3		Labor - CR Associates	\$30,084.24
4		Expenses - CR Associates	

Totals = **\$533,448.30**

**Table 2 - TASKS/WBS Summary (Costs & Hours)**

Item	TASKS/WBS	TASKS/WBS Description	Labor Hrs	Total Costs
1	1	Project Management and Coordination	270.0	\$59,602.64
2	2	Non-Residential Relocation Services	1,596.0	\$195,047.11
3	3	Property Management	495.0	\$278,798.55

Totals = **2,361.0** **\$533,448.30**

**Table 3 - Consultant/Subconsultant Summary (Costs & Hours)**

(If Applicable, Select One)				Consultant	Labor Hrs	Total Costs
DBE	DVBE	SBE	Other			
				Epic Land Solutions, Inc.	2,231.0	\$503,364.06
				CR Associates	130.0	\$30,084.24

Totals = **2,361.0** **\$533,448.30**

# Work Order Estimate

## Summary

Total Hours =	130
Total Costs =	\$30,084.24

Consultant/Subconsultant: **CR Associates**

MTS Doc. No.:    
 Work Order No.: **WOAXXX-AE-39**

Work Order Title: **CLEAN TRANSIT ADVANCEMENT CAMPUS (CTAC) TENANT RELOCATION SERVICES**

Attachment: **B**

Item	TASKS/WBS	TASKS/WBS Description	ODCs (See Attachment)	Contract Manager	Project Manager	Senior Engineer	Engineer - 3	Engineer - 2	Admin - 2					Total Hours	Totals
				\$ 314.41	\$ 310.92	\$ 257.35	\$ 199.71	\$ 161.13	\$ 125.76	\$ -	\$ -	\$ -	\$ -		
<b>1</b>	<b>Task 1</b>	<b>Project Management and Coordination</b>													
	1.1 - Project Management and Coordination (including meetings and file management)			10	60		10		50					130	\$30,084.24
		Subtotals (Hours) =	N/A	10	60		10		50					130	\$30,084.24
		Subtotals (Costs) =		\$3,144.08	\$18,654.95		\$1,997.07		\$6,288.15					<b>130</b>	<b>\$30,084.24</b>
<b>2</b>	<b>Task 2</b>	<b>Non-Residential Relocation Services</b>													
	2.1 - Relocation Plan														
	2.2 - Occupant Interview and Notices														
	2.3 - Present and Offer Fixtures and Equipment (F&E) Appraisal														
	2.4 - Relocation Assistance Advisory Services														
	2.5 - File Close-Out Documentation														
		Subtotals (Hours) =	N/A												
		Subtotals (Costs) =													
<b>3</b>	<b>Task 3</b>	<b>Property Management</b>													
	3.1 - Interim Property Management														
		Subtotals (Hours) =	N/A												
		Subtotals (Costs) =													
		<b>Totals (Summary) =</b>												<b>130</b>	<b>\$30,084.24</b>
		Total (Hours) =	N/A	10	60		10		50					130	
		Total (Costs) =		\$3,144.08	\$18,654.95		\$1,997.07		\$6,288.15						\$30,084.24
		Percentage of Total (Hours) =	N/A	8%	46%				38%					92%	
		Percentage of Total (Costs) =		10%	62%				21%						93%

### Work Order Estimate Summary

Consultant/ Subconsultant: **CR Associates**

Contract No:

Task Order No. **WOAXXX-AE-39**

Work Order Title: **CLEAN TRANSIT ADVANCEMENT CAMPUS (CTAC) TENANT RELOCATION SERVICES**

Attachment: **B**

#### TASKS/WBS (1-5)

ODC Item	Description	Unit	Unit Cost	Task 1		Task 2		Task 3		Task 4		Task 5	
				Quantity	Total	Quantity	Total	Quantity	Total	Quantity	Total	Quantity	Total
1	Postage/Overnight Packages	1	\$35.00										
2	Property Owner and Tenant Data	1	\$100.00										
3	Mileage	1	\$0.67										
4	Joshua Grading (Property Management)	1	\$2,500.00										
5	Apex Construction (Property Management)	1	\$1,500.00										

Subtotal =     Subtotal =     Subtotal =     Subtotal =     Subtotal =

#### TASKS/WBS (6-10)

ODC Item	Description	Task 1		Task 2		Task 3		Task 4		Task 5		Totals	
		Quantity	Total	Quantity	Total	Quantity	Total	Quantity	Total	Quantity	Total	Quantity	Total
1	Postage/Overnight Packages												
2	Property Owner and Tenant Data												
3	Mileage												
4	Joshua Grading (Property Management)												
5	Apex Construction (Property Management)												

Subtotal =     Subtotal =     Subtotal =     Subtotal =     Subtotal =     Totals =

# Work Order Estimate

## Summary

Total Hours =	2,231
Total Costs =	\$503,364.06

Consultant/Subconsultant: **Epic Land Solutions, Inc.**

MTS Doc. No.:    
 Work Order No.: **WOAXXX-AE-39**

Work Order Title: **CLEAN TRANSIT ADVANCEMENT CAMPUS (CTAC) TENANT RELOCATION SERVICES**

Attachment: **B**

Item	TASKS/WBS	TASKS/WBS Description	ODCs (See Attachment)	Right of Way Lead	Planner - Senior	Right of Way Assistant Manager	Senior Right of Way Agent	Admin 2	Project Controls - 3					Total Hours	Totals											
			\$	201.37	\$	197.65	\$	126.80	\$	117.91	\$	86.51	\$	147.70	\$	-	\$	-	\$	-	\$	-				
<b>1</b>	<b>Task 1</b>	<b>Project Management and Coordination</b>																								
	1.1 - Project Management and Coordination (including meetings and file management)		\$2,400.00	120						20														140	\$29,518.40	
		Subtotals (Hours) =	N/A	120						20														140	\$29,518.40	
		Subtotals (Costs) =	\$2,400.00							\$2,954.00														<b>140</b>	<b>\$29,518.40</b>	
<b>2</b>	<b>Task 2</b>	<b>Non-Residential Relocation Services</b>																								
	2.1 - Relocation Plan		\$1,935.00			25	50	6																81	\$11,519.56	
	2.2 - Occupant Interview and Notices				10		150	20																180	\$21,393.20	
	2.3 - Present and Offer Fixtures and Equipment (F&E) Appraisal				10		200	15																225	\$26,856.15	
	2.4 - Relocation Assistance Advisory Services				60		1000	15																1,075	\$131,066.65	
	2.5 - File Close-Out Documentation				5		20	10																35	\$4,211.55	
		Subtotals (Hours) =	N/A		85	25	1420	66																1,596	\$195,047.11	
		Subtotals (Costs) =	\$1,935.00		\$16,800.25	\$3,170.00	\$167,432.20	\$5,709.66																<b>1,596</b>	<b>\$195,047.11</b>	
<b>3</b>	<b>Task 3</b>	<b>Property Management</b>																								
	3.1 - Interim Property Management		\$200,000.00	215		280																		495	\$278,798.55	
		Subtotals (Hours) =	N/A	215		280																		495	\$278,798.55	
		Subtotals (Costs) =	\$200,000.00	\$43,294.55		\$35,504.00																		<b>495</b>	<b>\$278,798.55</b>	
		<b>Totals (Summary) =</b>																						<b>2,231</b>	<b>\$503,364.06</b>	
		Total (Hours) =	N/A	335	85	305	1420	66	20															2231		
		Total (Costs) =	\$204,335.00	\$67,458.95	\$16,800.25	\$38,674.00	\$167,432.20	\$5,709.66	\$2,954.00																	
		Percentage of Total (Hours) =	N/A	15%	4%	14%		3%	1%															36%		
		Percentage of Total (Costs) =	41%	13%	3%	8%		1%	1%																67%	

### Work Order Estimate Summary

Consultant/ Subconsultant: **Epic Land Solutions, Inc.**

Contract No:  

Task Order No. **WOAXXX-AE-39**

Work Order Title: **CLEAN TRANSIT ADVANCEMENT CAMPUS (CTAC) TENANT RELOCATION SERVICES**

Attachment: **B**

#### TASKS/WBS (1-5)

ODC Item	Description	Unit	Unit Cost	Task 1		Task 2		Task 3		Task 4		Task 5	
				Quantity	Total	Quantity	Total	Quantity	Total	Quantity	Total	Quantity	Total
1	Postage/Overnight Packages	1	\$35.00			17	\$595.00						
2	Property Owner and Tenant Data	1	\$100.00	24	\$2,400.00								
3	Mileage	1	\$0.67			2,000	\$1,340.00						
4	Joshua Grading (Property Management)	1	\$2,500.00					50	\$125,000.00				
5	Apex Construction (Property Management)	1	\$1,500.00					50	\$75,000.00				

Subtotal = \$2,400.00    Subtotal = \$1,935.00    Subtotal = \$200,000.00    Subtotal =      Subtotal =  

#### TASKS/WBS (6-10)

ODC Item	Description	Task 1		Task 2		Task 3		Task 4		Task 5		Totals	
		Quantity	Total	Quantity	Total	Quantity	Total	Quantity	Total	Quantity	Total	Quantity	Total
1	Postage/Overnight Packages											17	\$595.00
2	Property Owner and Tenant Data											24	\$2,400.00
3	Mileage											2,000	\$1,340.00
4	Joshua Grading (Property Management)											50	\$125,000.00
5	Apex Construction (Property Management)											50	\$75,000.00

Subtotal =      Subtotal =      Subtotal =      Subtotal =      Subtotal =      Totals = \$204,335.00



**Metropolitan  
Transit  
System**

**DRAFT FOR EXECUTIVE COMMITTEE REVIEW DATE: 4/11/2024**

## **Agenda Item No. 19**

MEETING OF THE SAN DIEGO METROPOLITAN TRANSIT SYSTEM  
BOARD OF DIRECTORS

April 25, 2024

**SUBJECT:**

State of California Office of Emergency Services – Designation of Applicant Agent Resolution

**RECOMMENDATION:**

That the San Diego Metropolitan Transit System (MTS) Board of Directors:

- 1) Authorize the Chief Executive Officer (CEO) and designee(s) to serve as MTS's agent to engage with the Federal Emergency Management Agency and the Governor's Office of Emergency Services regarding all matters pertaining to Federal financial assistance and/or State financial assistance under the California Disaster Assistance Act; and
- 2) Authorize the Chair of the Board of Directors to sign the Designation of Applicant's Agent Resolution for Non-State Agencies Form (CalOES Form 130) (Attachment A).

**Budget Impact**

None with this action.

**DISCUSSION:**

On January 22, 2024, San Diego County experienced historic rainfall for the month of January (2024 January Storm). The 2024 January Storm caused widespread flooding, mudslides, and debris flow threatening life and safety, structures, and other critical infrastructure. The impacts of this storm also caused evacuations, road and school closures, and widespread damage to public and private property. MTS transit infrastructure, facilities, and equipment sustained significant damage as a result of the storm.

On January 23, 2024, a Governor's Proclamation was issued to secure funding to help the County of San Diego respond to and recover from the 2024 January Storm. The 2024 January Storm makes California Disaster Assistance Act (CDA) funding available for eligible costs and entities within the County of San Diego. MTS falls under the list of entities eligible for disaster assistance under the CDA.



A Designation of Applicant's Agent Resolution for Non-State Agencies (CalOES Form 130) is required for MTS to be eligible to receive State and/or Federal funding. The resolution is universal and effective for all open and future emergencies/disasters up to three years following the date of approval by the Board. The attached resolution authorizes the following positions as authorized agents for MTS: CEO, General Counsel, and Chief Operating Officer.

Therefore, staff recommends that the MTS Board of Directors:

- 1) Authorize the CEO and designee(s) to serve as MTS's agent to engage with the Federal Emergency Management Agency and the Governor's Office of Emergency Services regarding all matters pertaining to Federal financial assistance and/or State financial assistance under the California Disaster Assistance Act; and
- 2) Authorize the Chair of the Board of Directors to sign the Designation of Applicant's Agent Resolution for Non-State Agencies Form (CalOES Form 130) (Attachment A).

/s/ Sharon Cooney  
Sharon Cooney  
Chief Executive Officer

Key Staff Contact: Julia Tuer, 619.557.4515, [Julia.Tuer@sdmts.com](mailto:Julia.Tuer@sdmts.com)

Attachment: A. Designation of Applicant's Agent Resolution for Non-State Agencies Form (CalOES Form 130)





**DESIGNATION OF APPLICANT'S AGENT RESOLUTION**

**NON-STATE AGENCIES**

Cal OES ID No: \_\_\_\_\_

OES-FPD-130 (Rev. 10-2022)

**DESIGNATION OF APPLICANT'S AGENT RESOLUTION FOR NON-STATE AGENCIES**

BE IT RESOLVED BY THE \_\_\_\_\_ OF THE \_\_\_\_\_  
(Governing Body) (Name of Applicant)

THAT \_\_\_\_\_, OR  
(Title of Authorized Agent)

\_\_\_\_\_, OR  
(Title of Authorized Agent)

\_\_\_\_\_  
(Title of Authorized Agent)

is hereby authorized to execute for and on behalf of the \_\_\_\_\_,  
(Name of Applicant)

a public entity established under the laws of the State of California, this application and to file it with the California Governor's Office of Emergency Services for the purpose of obtaining federal financial assistance for any existing or future grant program, including, but not limited to any of the following:

- **Federally declared Disaster (DR), Fire Mitigation Assistance Grant (FMAG), California State Only Disaster (CDAA), Immediate Services Program (ISP), Hazard Mitigation Grant Program (HMGP), Building Resilient Infrastructure and Communities (BRIC), Legislative Pre-Disaster Mitigation Program (LPDM),** under
- Public Law 93-288 as amended by the Robert T. Stafford Disaster Relief and Emergency Assistance Act of 1988, and/or state financial assistance under the California Disaster Assistance Act.
- **Flood Mitigation Assistance Program (FMA),** under Section 1366 of the National Flood Insurance Act of 1968.
- **National Earthquake Hazards Reduction Program (NEHRP)** 42 U.S. Code 7704 (b) ((2) (A) (ix) and 42 U.S. Code 7704 (b) (2) (B) National Earthquake Hazards Reduction Program, and also The Consolidated Appropriations Act, 2018, Div. F, Department of Homeland Security Appropriations Act, 2018, Pub. L. No. 115-141
- **California Early Earthquake Warning (CEEW)** under CA Gov Code – Gov, Title 2, Div. 1, Chapter 7, Article 5, Sections 8587.8, 8587.11, 8587.12

That the \_\_\_\_\_, a public entity established under the  
(Name of Applicant)

laws of the State of California, hereby authorizes its agent(s) to provide to the Governor's Office of Emergency Services for all matters pertaining to such state disaster assistance the assurances and agreements required.



**DESIGNATION OF APPLICANT'S AGENT RESOLUTION  
NON-STATE AGENCIES**

OES-FPD-130 (Rev. 10-2022)

**Please check the appropriate box below**

- This is a universal resolution and is effective for all open and future disasters/grants declared up to three (3) years following the date of approval.
- This is a disaster/grant specific resolution and is effective for only disaster/grant number(s): \_\_\_\_\_

Passed and approved this \_\_\_ day of \_\_\_\_\_, 20 \_\_\_\_

\_\_\_\_\_  
(Name and Title of Governing Body Representative)

\_\_\_\_\_  
(Name and Title of Governing Body Representative)

\_\_\_\_\_  
(Name and Title of Governing Body Representative)

**CERTIFICATION**

I, \_\_\_\_\_, duly appointed and \_\_\_\_\_ of  
(Name) (Title)

\_\_\_\_\_, do hereby certify that the above is a true and  
(Name of Applicant)

correct copy of a resolution passed and approved by the \_\_\_\_\_  
(Governing Body)

of the \_\_\_\_\_ on the \_\_\_\_\_ day of \_\_\_\_\_, 20 \_\_\_\_.  
(Name of Applicant)

\_\_\_\_\_  
(Signature)

\_\_\_\_\_  
(Title)



**DESIGNATION OF APPLICANT'S AGENT RESOLUTION**  
**NON-STATE AGENCIES**  
OES-FPD-130 (Rev. 10-2022)

**Cal OES Form 130 Instructions**

**A Designation of Applicant's Agent Resolution for Non-State Agencies is required of all Applicants to be eligible to receive funding. A new resolution must be submitted if a previously submitted resolution is older than three (3) years from the last date of approval, is invalid, or has not been submitted.**

When completing the Cal OES Form 130, Applicants should fill in the blanks on pages 1 and 2. The blanks are to be filled in as follows:

**Resolution Section:**

**Governing Body:** This is the group responsible for appointing and approving the Authorized Agents.

Examples include: Board of Directors, City Council, Board of Supervisors, Board of Education, etc.

**Name of Applicant:** The public entity established under the laws of the State of California.

Examples include: School District, Office of Education, City, County or Non-profit agency that has applied for the grant, such as: City of San Diego, Sacramento County, Burbank Unified School District, Napa County Office of Education, University Southern California.

**Authorized Agent:** These are the individuals that are authorized by the Governing Body to engage with the Federal Emergency Management Agency and the California Governor's Office of Emergency Services regarding grants for which they have applied. There are two ways of completing this section:

1. **Titles Only:** The titles of the Authorized Agents should be entered here, not their names. This allows the document to remain valid if an Authorized Agent leaves the position and is replaced by another individual. If "Titles Only" is the chosen method, this document must be accompanied by either a cover letter naming the Authorized Agents by name and title, or the Cal OES AA Names document. The supporting document can be completed by any authorized person within the Agency (e.g., administrative assistant, the Authorized Agent, secretary to the Director). It does not require the Governing Body's signature.
2. **Names and Titles:** If the Governing Body so chooses, the names **and** titles of the Authorized Agents would be listed. A new Cal OES Form 130 will be required if any of the Authorized Agents are replaced, leave the position listed on the document, or their title changes.



## DESIGNATION OF APPLICANT'S AGENT RESOLUTION NON-STATE AGENCIES

OES-FPD-130 (Rev. 10-2022)

---

**Checking Universal or Disaster-Specific Box:** A Universal resolution is effective for all past disasters and for those declared up to three (3) years following the date of approval. Upon expiration it is no longer effective for new disasters, but it remains in effect for disasters declared prior to expiration. It remains effective until the disaster goes through closeout unless it is superseded by a newer resolution.

**Governing Body Representative:** These are the names and titles of the approving Board Members.

Examples include: Chairman of the Board, Director, Superintendent, etc. The names and titles **cannot** be one of the designated Authorized Agents. A minimum of three (3) approving board members must be listed. If less than three are present, meeting minutes must be attached in order to verify a quorum was met.

### **Certification Section:**

**Name and Title:** This is the individual in attendance who recorded the creation and approval of this resolution.

Examples include: City Clerk, Secretary to the Board of Directors, County Clerk, etc. This person **cannot** be one of the designated Authorized Agents or Approving Board Member. If a person holds two positions (such as City Manager and Secretary to the Board) and the City Manager is to be listed as an Authorized Agent, then that person could sign the document as Secretary to the Board (not City Manager) to eliminate "Self-Certification."



**Metropolitan  
Transit  
System**

**DRAFT FOR EXECUTIVE COMMITTEE REVIEW DATE: 4/11/2024**

## **Agenda Item No. 20**

MEETING OF THE SAN DIEGO METROPOLITAN TRANSIT SYSTEM  
BOARD OF DIRECTORS

April 25, 2024

**SUBJECT:**

Improving Restroom Availability at San Diego State University Transit Center - Memorandum of Understanding Amendment

**INFORMATION ONLY**

Budget Impact

The budget impact is anticipated to be approximately \$95,000 in FY 2025 for maintenance and one-time improvements; and approximately \$60,000 annually.

**DISCUSSION:**

The San Diego Metropolitan Transit System (MTS) and San Diego State University (SDSU) executed a Memorandum of Understanding (MOU) on June 30, 2006, for the operation and maintenance for the Mission Valley East light rail transit extension's new transit center on the San Diego State University campus.

Public restrooms were built and located adjacent to the entrance to the underground Trolley station. The original MOU did not specify which entity was responsible for maintaining the restrooms. Section 6(a) of the MOU identifies all of the items that MTS is responsible for maintaining, but this list does not include the Public Restrooms. Section 6(b) states that SDSU will maintain all other items at the Station not identified in 6(a). Additionally, "Public Restrooms" is defined in Article 1, but never specifically referenced elsewhere in the MOU. This appears to place responsibility on SDSU for restroom operation and maintenance, but also does not require SDSU to keep the restrooms open for any particular period of time. Under this framework, MTS has never been in control of or responsible for the SDSU station restrooms. Approximately six years ago, the restrooms were closed temporarily, and then permanently, as a result of maintenance and security concerns.

As part of a larger Board policy discussion, the MTS Board asked staff to evaluate and identify where restroom access along the trolley system can be improved. SDSU was identified as a



potential location to more quickly improve restroom access, since only minimal capital improvements are necessary to re-open the restrooms. MTS and SDSU therefore engaged in discussions about potentially reopening the restrooms and sharing the costs of maintaining them.

This amendment, which will be substantially in the same format as Attachment A, will clearly define and identify each party's respective rights and duties related to the operation, maintenance and security for the public restrooms. Both parties agree the restrooms will generally be open during the hours the Trolley is open (approximately 5 a.m. to midnight) seven days week, for 365 days per year. SDSU will be responsible for the security, operation and maintenance of the public restrooms. It will be serviced on a regular schedule, and SDSU police will be the lead responder for any calls for assistance. MTS security officers will conduct routine patrols/inspections of the restrooms.

This MOU amendment commits MTS to reimburse SDSU fifty percent (50%) of the reasonable costs to operate, maintain and provide security. If maintenance issues arise in the Trolley's deluge system on MTS property, but the blockages are sourced at the SDSU restroom, SDSU will reimburse MTS fifty percent (50%) of the reasonable cost. The amendment also specifies that MTS will reimburse SDSU for fifty percent (50%) of pre-approved, one-time tenant improvements for the restrooms.

/s/ Sharon Cooney

Sharon Cooney  
Chief Executive Officer

Key Staff Contact: Julia Tuer, 619.557.4515, [Julia.Tuer@sdmts.com](mailto:Julia.Tuer@sdmts.com)

Attachment: A. Draft Amendment M6644.1-06 to SDSU Operating and Maintenance Agreement

Amendment No. 1 to  
OPERATION AND MAINTENANCE AGREEMENT  
FOR THE MISSION VALLEY EAST LIGHT RAIL TRANSIT EXTENSION,  
LIGHT RAIL TRANSIT STATION AND BUS CENTER AT SAN DIEGO STATE UNIVERSITY

This Amendment No. 1 (Amendment) to the Operation and Maintenance Agreement for the Mission Valley East Light Rail Transit Extension, Light Rail Transit (LRT) Station and Bus Center at San Diego State University (SDSU LRT O&M Agreement) is entered into as of \_\_\_\_\_, 2024 between The Trustees of the California State University, by and through San Diego State University (SDSU), and the San Diego Metropolitan Transit Development Board, also known as the San Diego Metropolitan Transit System (MTS) (collectively referred to herein as the "Parties").

RECITALS

A. Between 1999 and 2005, MTS constructed the Mission Valley East LRT Extension Project (Project), which included a 5.6-mile extension of the MTS Green Line from the Mission San Diego Station to Grossmont Center. The Project constructed four new trolley stations: Grantville, SDSU, Alvarado Medical Center, and 70<sup>th</sup> Street and connected this east-west trolley route from Old Town Transit Center to Santee.

B. The Parties entered into the SDSU LRT O&M Agreement on June 30, 2006 to establish each party's respective rights and duties related to the operation, maintenance and security for the LRT Extension, LRT Station and Bus Transit Center at SDSU, and SDSU's utilization of MTS's prior bus transit center.

C. As part of the Project, MTS constructed Public Restrooms (as defined in Article 1 of the SDSU LRT O&M Agreement) located at the entrance of the LRT Station at SDSU.

D. Article 6(a) and (b) of the SDSU LRT O&M Agreement govern the respective maintenance obligations of MTS and SDSU as it related to the LRT Station and Bus Transit Center at SDSU.

E. By this Amendment, the Parties desire to clarify and amend the responsibilities under the SDSU LRT O&M Agreement as it relates to the Public Restrooms.

AGREEMENT

Notwithstanding anything in the SDSU LRT O&M Agreement to the contrary, the Parties agree as follows:

1. Public Restrooms.

a. SDSU shall operate, maintain, and provide security for the Public Restrooms pursuant to hours that are reasonably related to classes, business meetings, special events, and other activities on the SDSU campus that generate more than minimal transit ridership at the LRT Station and the Bus Transit Center.

b. SDSU and MTS shall agree on schedule, which may be modified from time to time, and shall provide notice to MTS transit patrons and campus visitors of the hours of operation, but will not exceed the operation hours of the trolley. Notice may be through a combination of posted signs, website listings, printed materials, and other methods determined in SDSU and MTS's reasonable discretion.

c. MTS agrees to reimburse SDSU for fifty percent (50%) of the reasonable costs to operate, maintain, and provide security to the Public Restrooms as set forth in Paragraph 1(a) above. In addition, MTS agrees to reimburse SDSU for fifty percent (50%) of pre-approved tenant improvements for the Public Restrooms. On an annual basis, MTS and SDSU shall mutually agree to an estimated budget for the costs subject to reimbursement under this Paragraph 1(c). The initial estimated budget, for the pro-rated period of

May 1 to June 30, 2024, is set forth in Attachment A. Thereafter, in order to accommodate the parties' annual budgeting process, SDSU shall make good faith efforts to provide MTS with its budget estimate for the upcoming fiscal year (July 1 to June 30) no later than March 15<sup>th</sup> each year. All undisputed invoices shall be paid by MTS within thirty (30) days of receipt.

d. SDSU agrees to reimburse MTS for fifty percent (50%) of the reasonable costs, up to \$20,000 total or \$10,000 for MTS and \$10,000 for SDSU, for any plumbing obstruction repairs required in the Trolley tunnel's deluge system that are sourced at the Public Restrooms as defined in Article 1 of the SDSU LRT O&M Agreement. Any repairs over \$20,000 will require a negotiation between the CEO of MTS and Vice President for Business & Financial Affairs for SDSU or their designees

i. For any obstructions in the MTS deluge system, MTS will hire a mutually agreed upon third party expert to determine and document the source of the obstruction.

e. SDSU will make all reasonable efforts to document and respond to any plumbing issues in the Public Restrooms and notify MTS within 18 hours.

2. Term. This Amendment shall be coterminous with the SDSU LRT O&M Agreement; provided, however, that either party may terminate this Amendment and the obligations set forth in Paragraph 1, by providing the other party with at least 90 days written notice.

3. All other terms of the SDSU LRT O&M Agreement shall remain in full force and effect.

IN WITNESS WHEREOF, The Trustees of the California State University, by and through San Diego State University (SDSU), and the San Diego Metropolitan Transit Development Board have executed this Amendment No. 1 to the SDSU LRT O&M Agreement

SAN DIEGO STATE UNIVERSITY

SAN DIEGO METROPOLITAN TRANSIT  
DEVELOPMENT BOARD

By: \_\_\_\_\_  
Eric Hansen  
AVP - Business Operations

By: \_\_\_\_\_  
Sharon Cooney  
Chief Executive Officer

Date: \_\_\_\_\_

Date: \_\_\_\_\_

Approved as to form:

Approved as to form:

By: \_\_\_\_\_  
Office of the General Counsel for the  
California State University

By: \_\_\_\_\_  
Karen Landers  
MTS General Counsel



Attachment A

Initial Budget Estimate for Public Restroom Shared Costs

<b>Initial Budget Estimate for Public MTS/SDSU Restrooms - Shared Costs</b>		
<b>Scope</b>	<b>Frequency</b>	<b>Annual Costs</b>
Maintenance	As Needed	\$15,000
Custodial*	6 times per day	\$94,000
<a href="#">Crime Prevention Through Environmental Design (CPTED) Tenant Improvements</a>	One time	\$71,000
<b>ESTIMATED SUBTOTAL FOR YEAR ONE</b>		<b>180,000</b>
UPD Response**	As Needed	\$137
<b>ESTIMATED TOTAL FOR YEAR ONE</b>		<b>190,000</b>
SDSU Share of Expenses		<b>\$95,000</b>
MTS Share of Expenses		<b>\$95,000</b>
*Note: Opened and cleaned from 5am to midnight. Cleaned 6 times per day, seven days per week.		
**Note: Respond to calls for service or Brave system activation as needed. Minimum of 30 minutes charged for service. NTE 100 calls for service without review by SDSU and MTS.		





**Metropolitan  
Transit  
System**

## **Agenda Item No. 21**

**MEETING OF THE SAN DIEGO METROPOLITAN TRANSIT SYSTEM  
BOARD OF DIRECTORS**

April 25, 2024

**SUBJECT:**

Fiscal Year (FY) 2025 Capital Improvement Program (CIP) Amendment

**AGENDA ITEM WILL  
BE PROVIDED  
BEFORE BOARD  
MEETING**

**1255 Imperial Avenue, Suite 1000, San Diego, CA 92101-7490 • (619) 231-1466 • [sdmts.com](http://sdmts.com)**

San Diego Metropolitan Transit System (MTS) is a California public agency comprised of San Diego Transit Corp., San Diego Trolley, Inc. and San Diego and Arizona Eastern Railway Company (nonprofit public benefit corporations). MTS member agencies include the cities of Chula Vista, Coronado, El Cajon, Imperial Beach, La Mesa, Lemon Grove, National City, Poway, San Diego, Santee, and the County of San Diego. MTS is also the For-Hire Vehicle administrator for nine cities.





**Metropolitan  
Transit  
System**

**DRAFT FOR EXECUTIVE COMMITTEE REVIEW DATE: 4/11/2024**

## **Agenda Item No. 22**

**MEETING OF THE SAN DIEGO METROPOLITAN TRANSIT SYSTEM  
BOARD OF DIRECTORS**

April 25, 2024

**SUBJECT:**

ChargePoint ViriCiti Bus Telematics License Renewal-Sole Source Contract Award

**AGENDA ITEM WILL  
BE PROVIDED  
BEFORE BOARD  
MEETING**

**1255 Imperial Avenue, Suite 1000, San Diego, CA 92101-7490 • (619) 231-1466 • [sdmts.com](http://sdmts.com)**

San Diego Metropolitan Transit System (MTS) is a California public agency comprised of San Diego Transit Corp., San Diego Trolley, Inc. and San Diego and Arizona Eastern Railway Company (nonprofit public benefit corporations). MTS member agencies include the cities of Chula Vista, Coronado, El Cajon, Imperial Beach, La Mesa, Lemon Grove, National City, Poway, San Diego, Santee, and the County of San Diego. MTS is also the For-Hire Vehicle administrator for nine cities.

